

## Cup Plugs – Inch – Non-Preferred

### 1. GENERAL

Cup plugs are made in three different types:

- Standard plugs for general production applications
- Stainless steel plugs are considered special because of cost and limited availability
- Salvage plugs for use in salvage operations only and should not be designed into products.

All dimensions in this standard are in inches.

### 2. RELATED DOCUMENTS

#### 2.1 REFERENCE STANDARDS

STPA020—Fastener Finishes and Material Specifications

#### 2.2 REPLACED STANDARDS

Case J-060—Cup Plugs (General Specifications)

Case J-061—Cup Plugs - Preferred

Case J-062—Cup Plugs - Stainless – Non-Preferred

Case J-063—Cup Plugs - Salvage – Non-Preferred

Case J-064—Cup Plugs - Special – Non-Preferred

### 3. PREFERRED PARTS POLICY

All standard parts measured in inches are considered non-preferred. See STPJ620 for preferred parts (metric).

### 4. CROSS REFERENCE

For cross reference listing of company part numbers, go to [CNH Catalogue](#).

### 5. MATERIAL AND FINISH

Cup plugs shall be made of carbon steel (CST) or stainless steel (SST), 200 or 300 series. All cup plugs shall be furnished plain (PLN).

### 6. ASSEMBLY

6.1 The recommended hole diameter limits specified will provide suitable assembly under average conditions. However, deviations from these recommendations may be desirable to provide optimum assembly and performance for particular conditions.

|                           |                     |                          |                                |                |
|---------------------------|---------------------|--------------------------|--------------------------------|----------------|
| ISSUED BY<br>AK 05JUN15   | ECN NO.<br>35219392 | NAME<br><b>CUP PLUGS</b> |                                |                |
| APPROVED BY<br>PT 05JUN15 | REV.<br>L           | PAGE<br>1 OF 9           | CNH NUMBERS<br><b>87366810</b> | <b>STPJ280</b> |

THE INFORMATION HEREON IS THE CONFIDENTIAL AND PROPRIETARY PROPERTY OF CNH GLOBAL N.V. AND/OR ITS SUBSIDIARIES OR DIVISIONS. ANY USE, EXCEPT THAT FOR WHICH IT MAY BE LOANED, IS PROHIBITED.

6.2 An appropriate lubricating oil is recommended wherever possible during installation of plugs to facilitate insertion and prevent galling.

6.3 To aid assembly and prevent scoring of plugs at insertion, it is recommended that the entering edge of hole be relieved with as large a tangential radius as the wall thickness will permit. An alternative, although less favorable, option is a countersink of 30° maximum included angle; to a minimum diameter of .012 to .016 inch larger than the plug in its free state. The depth of the relief shall be such as to permit the open end of a plug to be inserted .010 inch minimum beyond the point of tangency or intersection of countersink on wall of hole.

## 7. INSTALLATION

7.1 Plugs should be driven from the inside bottom and not from the outer edge, or rim of the cup. This can best be accomplished by use of a round arbor .020 or .025 inch smaller in diameter than the inside diameter of plug ( $A_{min} - 2C_{max}$ ), the driving end is flat and perpendicular to the axis of the arbor with edge rounded to .06 inch radius.

7.2 Where plugs are used in counter bored holes, care should be exercised in insertion to prevent the plug from bottoming on the shoulder of counter bore which could result in distortion of plug and loss of seal.

|                          |           |                |                                |                |
|--------------------------|-----------|----------------|--------------------------------|----------------|
| NAME<br><b>CUP PLUGS</b> | REV.<br>L | PAGE<br>2 OF 9 | CNH NUMBERS<br><b>87366810</b> | <b>STPJ280</b> |
|--------------------------|-----------|----------------|--------------------------------|----------------|

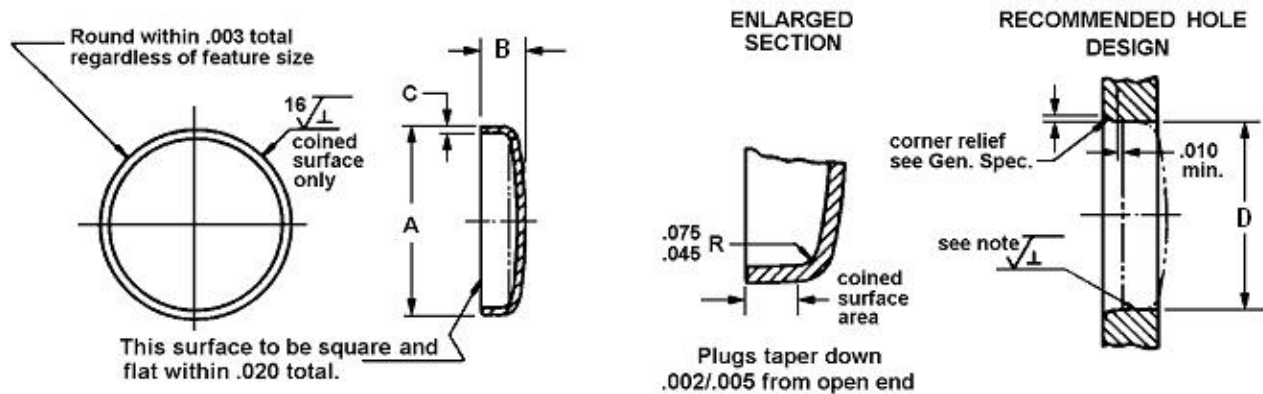

**FIGURE 1: Standard Type Cup Plug Diagram**

**TABLE 1: Basic Dimensions in Inches for Standard**

| Nominal Plug Size |       | Outside Diameter* |       | Overall Height |      | Stock Thickness | Recommended Hole Diameter** |       |
|-------------------|-------|-------------------|-------|----------------|------|-----------------|-----------------------------|-------|
|                   |       | A                 |       | B              |      | C               | D                           |       |
|                   |       | Max               | Min   | Max            | Min  | ±.003           | Max                         | Min   |
| 3/16              | 0.188 | .199              | .197  | .155           | .105 | .030            | .192                        | .194  |
| 5/16              | 0.313 | .318              | .316  | .208           | .168 | .040            | .310                        | .312  |
| 3/8               | 0.375 | .387              | .385  | .208           | .168 | .040            | .379                        | .381  |
| 7/16              | 0.438 | .449              | .447  | .208           | .168 | .040            | .440                        | .442  |
| 1/2               | 0.500 | .512              | .510  | .270           | .230 | .040            | .504                        | .506  |
| 9/16              | 0.562 | .574              | .572  | .270           | .230 | .040            | .566                        | .568  |
| 5/8               | 0.625 | .637              | .635  | .270           | .230 | .040            | .629                        | .631  |
| 11/16             | 0.688 | .699              | .697  | .270           | .230 | .040            | .691                        | .693  |
| 3/4               | 0.750 | .762              | .760  | .270           | .230 | .050            | .754                        | .756  |
| 13/16             | 0.813 | .825              | .823  | .270           | .230 | .050            | .817                        | .819  |
| 7/8               | 0.875 | .887              | .885  | .270           | .230 | .050            | .879                        | .881  |
| 15/16             | 0.938 | .941              | .937  | .500           |      | .048            | .931                        | .934  |
| 1                 | 1.000 | 1.012             | 1.010 | .330           | .290 | .050            | 1.002                       | 1.005 |
| 1-1/8             | 1.125 | 1.137             | 1.135 | .330           | .290 | .050            | 1.127                       | 1.130 |
| 1-1/4             | 1.250 | 1.262             | 1.260 | .330           | .290 | .050            | 1.252                       | 1.255 |
| 1-3/8             | 1.375 | 1.388             | 1.386 | .330           | .290 | .060            | 1.378                       | 1.381 |
| 1-1/2             | 1.500 | 1.508             | 1.506 | .330           | .290 | .060            | 1.497                       | 1.500 |
| 1-5/8             | 1.625 | 1.642             | 1.640 | .380           | .340 | .060            | 1.631                       | 1.634 |
| 1-3/4             | 1.750 | 1.762             | 1.760 | .380           | .340 | .060            | 1.751                       | 1.754 |
| 1-7/8             | 1.875 | 1.887             | 1.885 | .380           | .340 | .060            | 1.876                       | 1.879 |
| 2                 | 2.000 | 2.012             | 2.010 | .380           | .340 | .060            | 2.001                       | 2.004 |
| 2-1/8             | 2.125 | 2.138             | 2.135 | .380           | .340 | .060            | 2.126                       | 2.129 |
| 2-1/4             | 2.250 | 2.263             | 2.260 | .380           | .340 | .060            | 2.251                       | 2.254 |

|      |                  |      |        |                         |
|------|------------------|------|--------|-------------------------|
| NAME | <b>CUP PLUGS</b> | REV. | PAGE   | CNH NUMBERS             |
|      |                  | L    | 3 OF 9 | <b>87366810 STPJ280</b> |

**TABLE 1: Basic Dimensions in Inches for Standard (Continued)**

| Nominal Plug Size |       | Outside Diameter* |       | Overall Height |      | Stock Thickness | Recommended Hole Diameter** |        |
|-------------------|-------|-------------------|-------|----------------|------|-----------------|-----------------------------|--------|
|                   |       | A                 |       | B              |      | C               | D                           |        |
|                   |       | Max               | Min   | Max            | Min  | ±.003           | Max                         | Min    |
| 2-3/8             | 2.375 | 2.389             | 2.386 | .380           | .340 | .060            | 2.377                       | 2.380  |
| 2-1/2             | 2.500 | 2.513             | 2.510 | .440           | .380 | .070            | 2.500                       | 2.504  |
| 2-5/8             | 2.625 | 2.638             | 2.635 | .440           | .380 | .070            | 2.625                       | 2.629  |
| 2-3/4             | 2.750 | 2.763             | 2.760 | .440           | .380 | .070            | 2.750                       | 2.754  |
| 2-7/8             | 2.875 | 2.888             | 2.885 | .440           | .380 | .070            | 2.875                       | 2.879  |
| 3                 | 3.000 | 3.013             | 3.010 | .540           | .480 | .070            | 3.000                       | 3.004  |
| 3-1/8             | 3.125 | 3.138             | 3.135 | .540           | .480 | .070            | 3.125                       | 3.129  |
| 3-1/4             | 3.250 | 3.263             | 3.260 | .540           | .480 | .070            | 3.250                       | 3.254  |
| 3-3/8             | 3.375 | 3.383             | 3.380 | .540           | .480 | .070            | 3.369                       | 3.372  |
| 3-5/8             | 3.625 | 3.635             | 3.632 | .540           | .480 | .070            | 3.621                       | 3.624  |
| 3-7/8             | 3.875 | 3.890             | 3.887 | .540           | .480 | .070            | 3.8745                      | 3.8775 |

\* Average of maximum and minimum measured diameters of coined surface. Diameter below coined surface may be .0025 inch undersize.

\*\* Hole diameters shown are for general applications, see General Specifications.

Note: Suggested bore finish should not exceed 100 microinch (AA) for maximum efficiency.

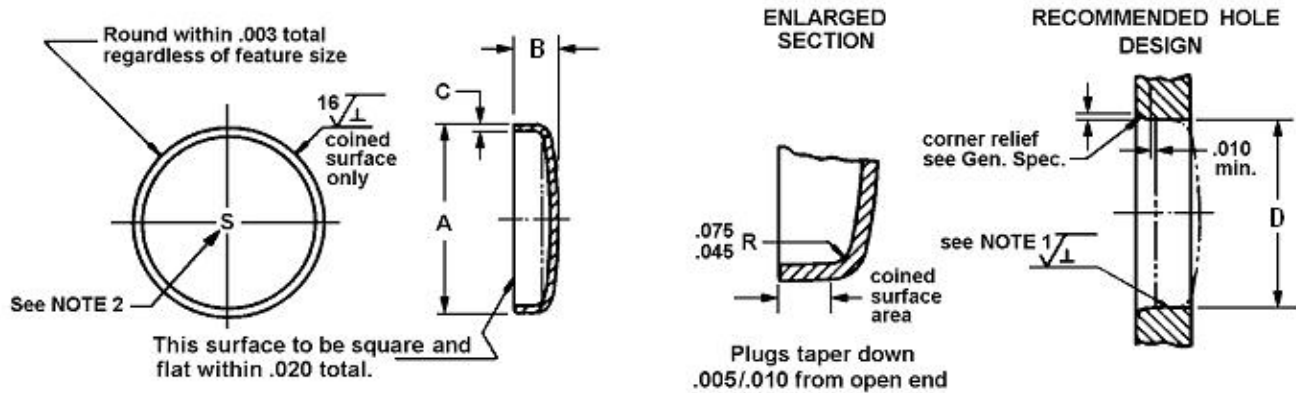

**FIGURE 2: Stainless Steel Type Cup Plug Diagram**

**TABLE 2: Basic Dimensions in Inches for Stainless Steel**

| Nominal Plug Size |       | Outside Diameter* |       | Overall Height |      | Stock Thickness | Recommended Hole Diameter** |       |
|-------------------|-------|-------------------|-------|----------------|------|-----------------|-----------------------------|-------|
|                   |       | A                 |       | B              |      | C               | D                           |       |
|                   |       | Max               | Min   | Max            | Min  | ±.003           | Max                         | Min   |
| 1/16              | 0.312 | .318              | .316  | .208           | .168 | .042            | .310                        | .312  |
| 5/8               | 0.625 | .639              | .636  | .280           | .240 | .042            | .629                        | .631  |
| 3/4               | 0.750 | .765              | .762  | .280           | .240 | .050            | .754                        | .756  |
| 7/8               | 0.875 | .891              | .887  | .280           | .240 | .050            | .879                        | .881  |
| 1                 | 1.000 | 1.016             | 1.012 | .340           | .300 | .050            | 1.002                       | 1.005 |
| 1-1/8             | 1.125 | 1.140             | 1.136 | .340           | .300 | .050            | 1.127                       | 1.130 |
| 1-1/4             | 1.250 | 1.266             | 1.262 | .340           | .300 | .050            | 1.252                       | 1.255 |
| 1-3/8             | 1.375 | 1.394             | 1.390 | .340           | .300 | .060            | 1.378                       | 1.381 |
| 1-1/2             | 1.500 | 1.514             | 1.510 | .340           | .300 | .060            | 1.497                       | 1.500 |
| 1-5/8             | 1.625 | 1.649             | 1.645 | .390           | .350 | .060            | 1.631                       | 1.634 |
| 1-3/4             | 1.750 | 1.768             | 1.763 | .390           | .350 | .060            | 1.751                       | 1.754 |
| 2                 | 2.000 | 2.019             | 2.015 | .390           | .350 | .060            | 2.001                       | 2.004 |
| 2-1/4             | 2.250 | 2.268             | 2.263 | .390           | .350 | .060            | 2.251                       | 2.254 |
| 3-1/4             | 3.250 | 3.269             | 3.264 | .540           | .480 | .060            | 3.250                       | 3.254 |

\* Average of maximum and minimum measured diameters of coined surface. Diameter below coined surface may be .0025 inch undersize.

\*\* Hole diameters shown are for general applications, see General Specifications.

Note: 1. Suggested bore finish should not exceed 100 microinch (AA) for maximum efficiency.

2. All stainless steel plugs must be stamped with the letter 'S' in the center of the concave portion of each plug.

|      |                  |      |   |      |        |             |                 |                |
|------|------------------|------|---|------|--------|-------------|-----------------|----------------|
| NAME | <b>CUP PLUGS</b> | REV. | L | PAGE | 5 OF 9 | CNH NUMBERS | <b>87366810</b> | <b>STPJ280</b> |
|------|------------------|------|---|------|--------|-------------|-----------------|----------------|

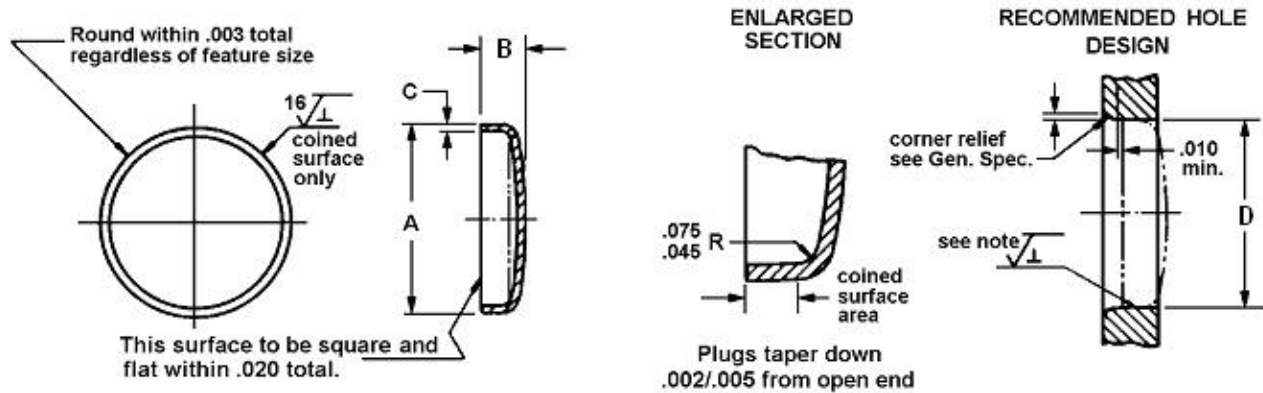

**FIGURE 3: Salvage Type Cup Plug Diagram**

**TABLE 3: Basic Dimensions in Inches for Salvage**

| Nominal Plug Size |       | Outside Diameter* |       | Overall Height |      | Stock Thickness | Recommended Hole Diameter** |       |
|-------------------|-------|-------------------|-------|----------------|------|-----------------|-----------------------------|-------|
|                   |       | A                 |       | B              |      | C               | D                           |       |
|                   |       | Max               | Min   | Max            | Min  | ±.003           | Max                         | Min   |
| 1-3/16            | 1.188 | 1.198             | 1.196 | .330           | .290 | .050            | 1.188                       | 1.191 |
| 1-5/16            | 1.312 | 1.326             | 1.324 | .330           | .290 | .050            | 1.316                       | 1.319 |
| 1-7/16            | 1.438 | 1.449             | 1.447 | .330           | .290 | .060            | 1.439                       | 1.442 |
| 1-13/16           | 1.813 | 1.825             | 1.823 | .380           | .340 | .060            | 1.814                       | 1.817 |
| 2-3/16            | 2.188 | 2.200             | 2.197 | .380           | .340 | .060            | 2.188                       | 2.191 |

\* Average of maximum and minimum measured diameters of coined surface. Diameter below coined surface may be .0025 inch undersize.

\*\* Hole diameters shown are for general applications, see General Specifications.

Note: Suggested bore finish should not exceed 100 microinch (AA) for maximum efficiency.

|      |                  |      |   |      |        |             |                 |                |
|------|------------------|------|---|------|--------|-------------|-----------------|----------------|
| NAME | <b>CUP PLUGS</b> | REV. | L | PAGE | 6 OF 9 | CNH NUMBERS | <b>87366810</b> | <b>STPJ280</b> |
|------|------------------|------|---|------|--------|-------------|-----------------|----------------|



# Standard Parts

**TABLE 4: Inch Standard Cup Plugs, CST, PLN**

| Nominal Plug Size | Plug Height | Part Number |
|-------------------|-------------|-------------|
| A                 | B           |             |
| 1                 | .310        | 86523365    |
| 1-1/8             | .330        | 87016638    |
| 1-1/2             | .310        | 86637817    |
| 1-5/8             | .370        | 47574069    |
| 1-3/4             | .380        | 87026939    |
| 2                 | .380        | 84129703    |
| 2-3/8             | .380        | 87026052    |
| 2-1/2             | .440        | 70930423    |
| 3-1/8             | .510        | 47574092    |

**TABLE 5: Inch Stainless Steel Cup Plugs, SST, PLN**

| Nominal Plug Size | Plug Height | Part Number |
|-------------------|-------------|-------------|
| A                 | B           |             |
| 1                 | .340        | 86625124    |
| 1-1/8             | .330        | 87026321    |
| 1-1/2             | .320        | 87672173    |
| 1-3/4             | .380        | 84403352    |

**TABLE 6: Inch Salvage Cup Plugs, CST, PLN**

| Nominal Plug Size | Plug Height | Part Number |
|-------------------|-------------|-------------|
| A                 | B           |             |
|                   |             |             |

**FIGURE 4: Non-Preferred Type Cup Plug Diagram**  
Effort should be made to choose standard plugs from Table 1 and 4

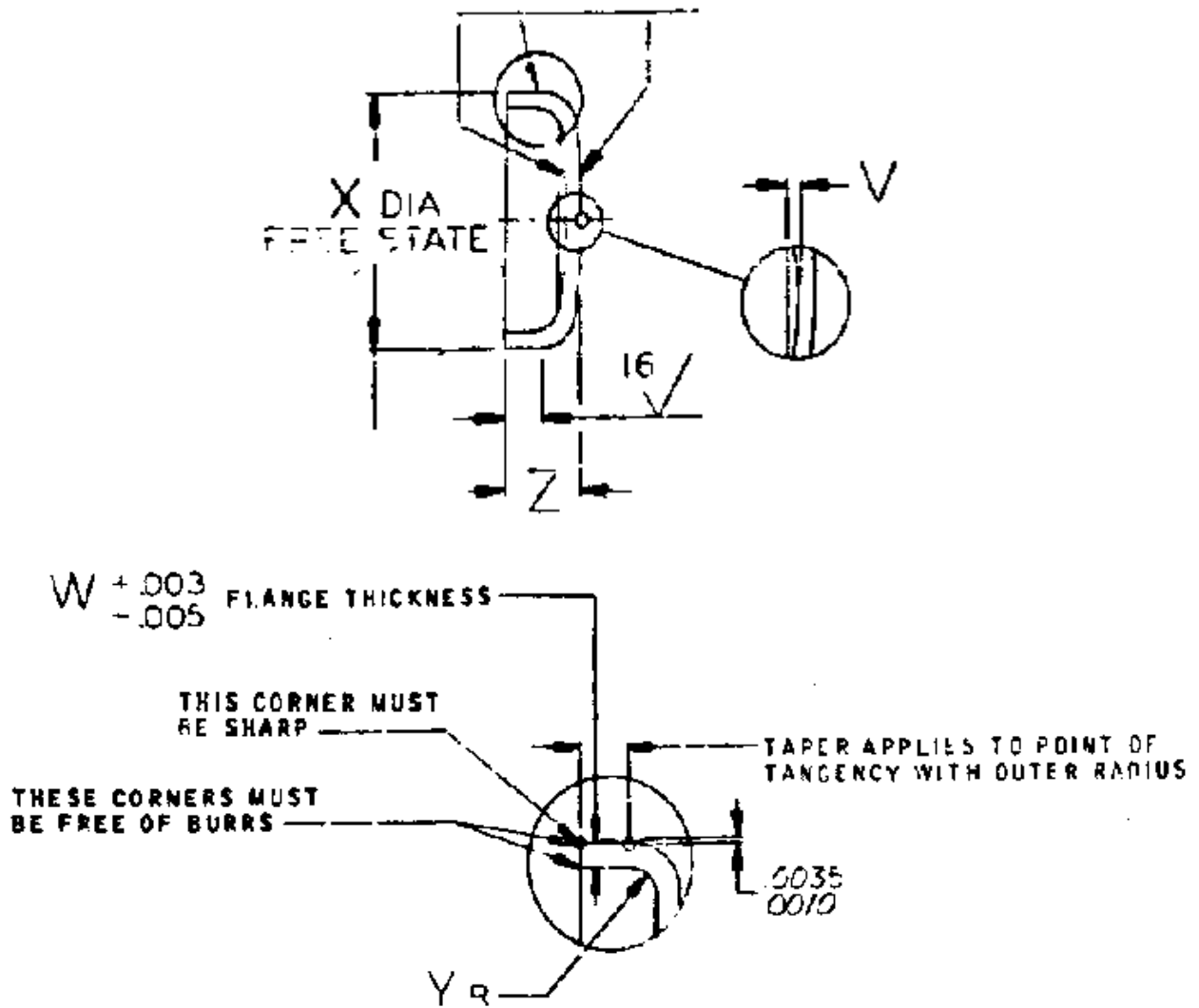

See Table 7 for Dimensions.

|      |           |           |                |                         |         |
|------|-----------|-----------|----------------|-------------------------|---------|
| NAME | CUP PLUGS | REV.<br>L | PAGE<br>8 OF 9 | CNH NUMBERS<br>87366810 | STPJ280 |
|------|-----------|-----------|----------------|-------------------------|---------|

**TABLE 7: Basic Dimensions in Inches for Figure 4, CST, PLN**

| CNH Part Number | OUTSIDE DIAMETER |       | OVERALL HEIGHT |      | FLANGE THICKNESS | INSIDE FILLET RADIUS |       | CROWN |      | RECOMMENDED HOLE SIZE |       |
|-----------------|------------------|-------|----------------|------|------------------|----------------------|-------|-------|------|-----------------------|-------|
|                 | X                |       | Z              |      | W                | Y                    |       | V     |      | U                     |       |
|                 | MAX              | MIN   | MAX            | MIN  | +/-0.003         | MAX                  | MIN   | MAX   | MIN  | MAX                   | MIN   |
| 47562575        | 0.877            | 0.875 | 0.27           | 0.23 | 0.050            | 0.075                | 0.030 | 0.03  | 0.10 | 0.871                 | 0.86  |
| 47562582        | 1.004            | 1.002 | 0.29           | 0.25 | 0.050            | 0.075                | 0.030 | 0.05  | 0.02 | 0.998                 | 0.996 |
| 83417039        | 1.012            | 1.010 | 0.29           | 0.25 | 0.050            | 0.075                | 0.030 | 0.05  | 0.02 | 1.005                 | 1.002 |
| 47562605        | 1.070            | 1.068 | 0.34           | 0.29 | 0.050            | 0.075                | 0.030 | 0.05  | 0.02 | 1.063                 | 1.060 |

**TABLE 8: Basic Dimensions in Inches for Figure 4, CST, ZND**

| CNH Part Number | OUTSIDE DIAMETER |       | OVERALL HEIGHT |      | FLANGE THICKNESS | INSIDE FILLET RADIUS |       | CROWN |      | RECOMMENDED HOLE SIZE |       |
|-----------------|------------------|-------|----------------|------|------------------|----------------------|-------|-------|------|-----------------------|-------|
|                 | X                |       | Z              |      | W                | Y                    |       | V     |      | U                     |       |
|                 | MAX              | MIN   | MAX            | MIN  | +/-0.003         | MAX                  | MIN   | MAX   | MIN  | MAX                   | MIN   |
| 83956679        | 0.825            | 0.823 | 0.27           | 0.23 | 0.050            | 0.075                | 0.030 | 0.05  | 0.02 | 0.819                 | 0.817 |