

PRODUCT SPECIFICATION

FSE Heavy Duty Countertop Hotplates

features

Model: CULCTH12NG



CULCTH12NG

This countertop gas cooking equipment from FSE is a must have for any foodservice commercial kitchen. Gas countertop hotplates are a space-saving alternative to full-size restaurant ranges, and are the perfect choice for preparing soups, stocks, steaks, and other delicious entrees. Each burner has its own individual standing pilot light and control, allowing you to set different cooking zones. ETL Listed and ETL Sanitation, this unit is backed by a 1-year warranty.

STANDARD FEATURES

- Stainless steel front and sides that are fully welded for extra durability
- Separate gas valves for each burner, with standing pilot ignition system
- Removable stainless steel drip tray,
- 3/4" NPT rear gas connection and pressure regulator
- 4" to 5" adjustable legs
- ETL listed and ETL sanitation

HOTPLATE CONFIGURATIONS

- 12" wide with two cast iron burners
- 25,000 BTU per burner
- Field convertible to liquid propane (LP)

RESIDENTIAL: FSE assumes no liability for parts or labor coverage for component failure, factory defect or any other damages for units installed in non-commercial foodservice or residential applications.

FOOD SERVICE EQUIPMENT

For Food Service Professionals

STANDARD FEATURES

- Stainless steel front and sides
- Fully welded to withstand the toughest kitchen environments
- 25,000 BTU per burner
- Separate gas valves for each burner, with standing pilot ignition system
- High output, gas powered for operators requiring all day long use—breakfast, lunch and dinner
- Two cast iron burners with 12" grate
- Removable stainless steel drip tray for easy cleaning
- 3/4" rear NPT gas inlet
- 4" to 5" adjustable legs

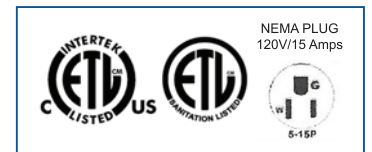

Attention CA Residents PROP 65 WARNING

This product can expose you to chemicals, including lead, which are known to the State of California to cause cancer, birth defects, or other reproductive harm.

For more information, go to www.P65warnings.ca.gov

MADE IN CHINA



PRODUCT SPECIFICATION

FSE Heavy Duty Countertop Hotplates

features

Model: CULCTH12NG

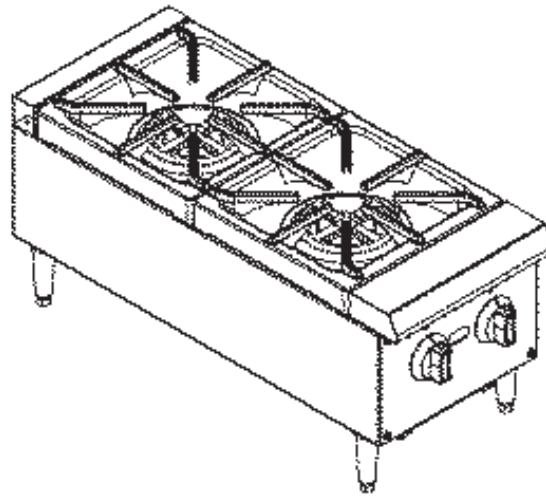
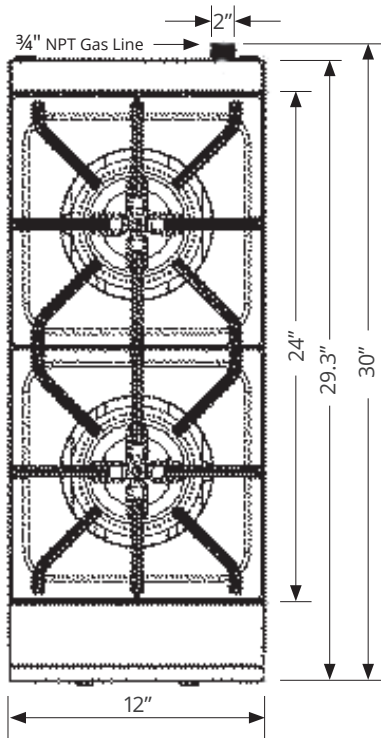
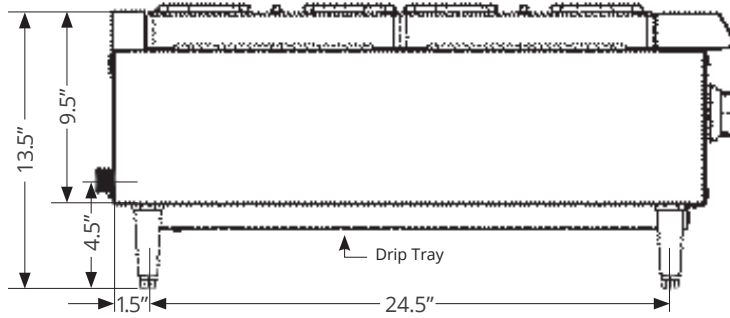
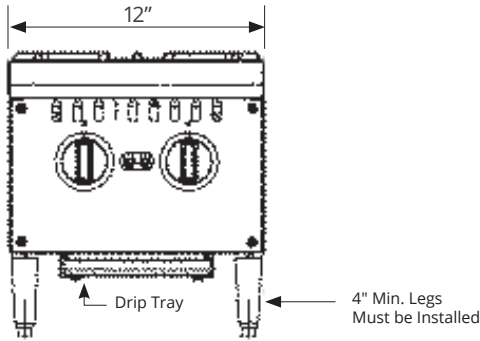

PRODUCT DETAILS

HEAVY DUTY HOTPLATE

Model Number	CULCTH12NG
Total BTU	50,000
Number of Burners	2
Number of Drip Trays	1
Overall Dimensions (in)	12"W x 30"D x 13.5"H
Net Weight (lbs)	62
Gross Weight (lbs)	95
Shipping Dimensions (in)	17"W x 35"D x 17"H

