



OPERATIONS & PARTS MANUAL

FOR MODELS:

- BE-QH1GI

PURCHASE DATE	MODEL NO.	SERIAL NUMBER
DEALER		

SAFETY WARNINGS AND PRECAUTIONS

⚠ WARNING:

When using tool, basic safety precautions should always be followed to reduce the risk of personal injury and damage to equipment.

Read all instructions before using this tool!

1. Keep work area clean. Cluttered areas invite injuries.
2. Keep children away. Children must never be allowed in the work area. Do not let them handle machines, tools or extension cords.
3. Store idle equipment. When not in use, tools must be stored in a dry location to inhibit rust. Always lock up tools and keep out of reach of children.
4. Use the right tool for the job. Do not attempt to force a small tool or attachment to do the work of a larger industrial tool. There are certain applications for which this tool was designed. It will do the job better and more safely at the rate for which it was intended. Do not modify this tool and do not use this tool for a purpose for which it was not intended.
5. Dress properly. Do not wear loose clothing or jewelry as they can be caught in moving parts. Protective, electrically non-conductive clothes and non-skid footwear are recommended when working. Wear restrictive hair covering to contain long hair.
6. Use eye and ear protection and protective clothing. Always wear ANSI approved impact safety goggles. Wear an ANSI approved dust mask or respirator when working around metal, wood and chemical dusts and mists. Wearing of gloves and protective clothing is recommended.
7. Do not overreach. Keep proper footing and balance at all times.
8. Maintain tools with care. Keep tools clean for better and safer performance. Follow instructions for lubricating and changing accessories.
9. Remove adjusting keys and wrenches. Check that keys and adjusting wrenches are removed from the tool or machine work surface before plugging it in.
10. Stay alert. Watch what you are doing, use common sense. Do not operate any tool when you are tired.
11. Check for damaged parts. Before using any tool, any part that appears damaged should be carefully checked to determine that it will operate properly and perform its intended function.
12. Replacement parts and accessories. When servicing, use only identical replacement parts. Use of any other parts will void the warranty. Only use accessories intended for use with this tool. Approved accessories are available from Harbor Freight Tools.
13. Do not operate tool if under the influence of alcohol or drugs. Read warning labels if taking prescription medicine to determine if your judgment or reflexes are impaired while taking drugs. If there is any doubt, do not operate the tool.
14. Maintenance. For your safety, service and maintenance should be performed regularly by a qualified technician.

PRODUCT SPECIFIC SAFETY PRECAUTIONS

1. Moving parts can cause injury. Keep hands, hair, loose clothing and tools away from moving parts of the Hitch. Keep spectators away at a safe distance.
2. Use the hitch on a proper surface. Locate on a flat, level and solid surface that is capable of supporting the weight of the Hitch and attached implement, plus the load.
3. Avoid accidents while using the Hitch and its attached implement. This product is for off-road use only.

⚠ WARNING:

The warnings, cautions and instructions discussed in this instruction manual cannot cover all possible conditions and situations that may occur. It must be understood by the operator that common sense and caution are factors which cannot be built into this product, but must be supplied by the operator.

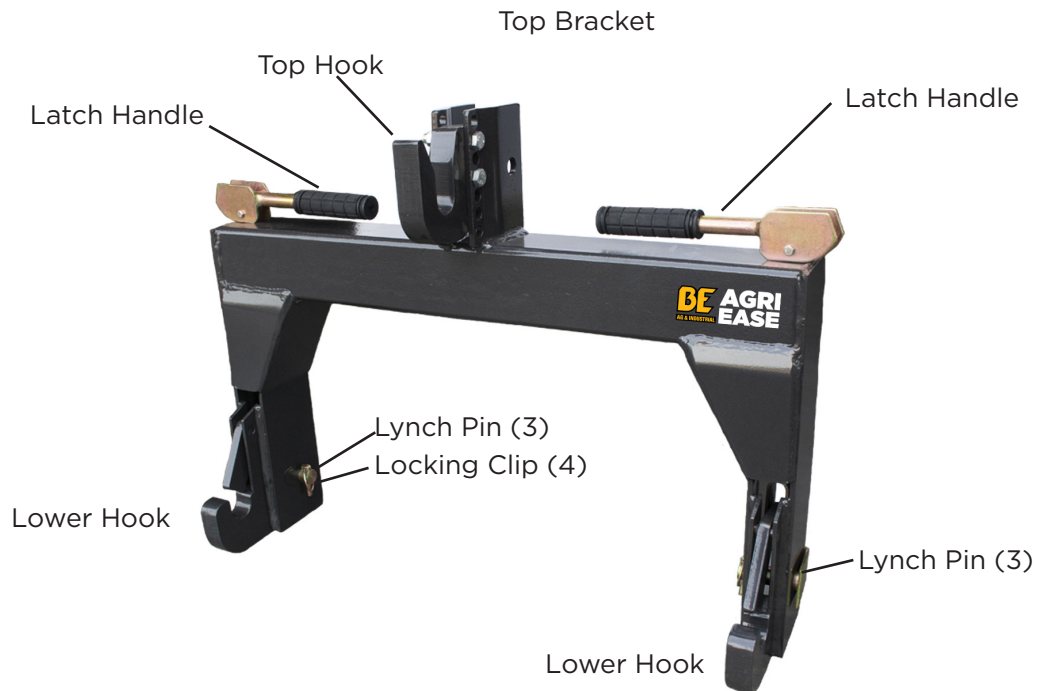

INSTALLATION

Note: It is recommended that 2 people assist in the setting up of this product.

1. Fasten the Quick Hitch to the tractor's lift arms using the solid Link Pins (not provided) with a flat bracket on one end and Lynch Pins (3). See illustration below.
2. Fasten the tractor's Center Link to the top bracket of the Quick Hitch using a common Link Pin (not provided). Place the Tractor Lift Arms into the lower pin holes and insert Lynch Pins and Locking Clips.
3. Install a common top Link Pin (not provided) on the implement's top framework for the Quick Hitch Top Hook to grab on. Note: This Top Hook is adjustable.
4. Insert the implement's lower mounts inside the hitch hooks and lock by pressing down the latch handles.
5. Check that all connections are tight before starting the work task.

Note: If the tractor has stabilizer arms, they will not fit into the Quick Hitch mounting area along with the lift arms. For this reason, use stabilizer chains, or some other common longer Mounting Pin (not provided) to fasten the Quick Hitch to the tractor.

INSTALLATION & MOUNTING

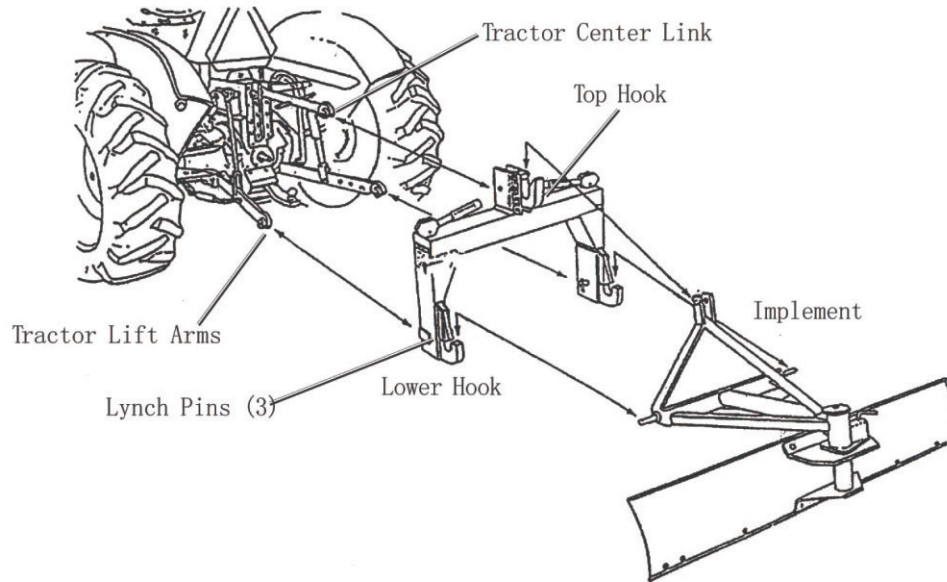

MOUNTING NON-ASAE IMPLEMENTS

If the implement is not of ASAE specifications, use an Adapter Bracket (not provided) to mount it to the Quick Hitch as illustrated below.

1. Remove the Top Hook by taking out the two Hex bolts (2), Lock Washers (6), and Nut (7). Save hardware.
2. Slide the Adapter Bracket (not provided) over the top bracket of the Quick Hitch and attach the top Link Pin (not provided). For most implements, the front hole (closest to implement) is recommended for the best vertical alignment.
3. Attach the implement to the Adapter Bracket tab with a Link Pin (not provided)
4. Check that all connections are tight before starting the work task

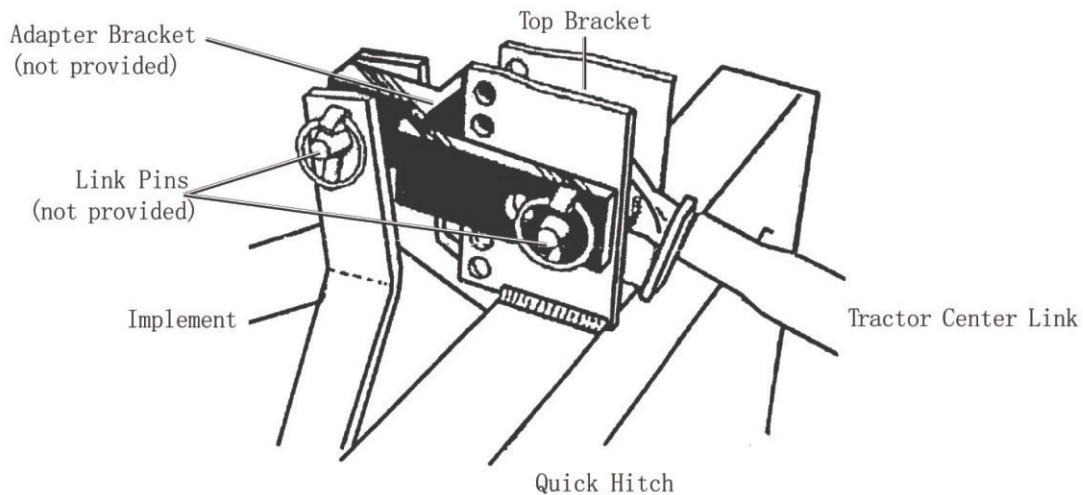

MAINTENANCE

1. Clean dirt and debris off the Quick Hitch after each use.
2. Store in a clean and dry location.
3. Periodically lubricate all moving parts.
4. After each use check for damaged or overly worn parts. Never use the Quick Hitch or attached implement if damaged or worn parts are noted.

QUICK HITCH PARTS LIST

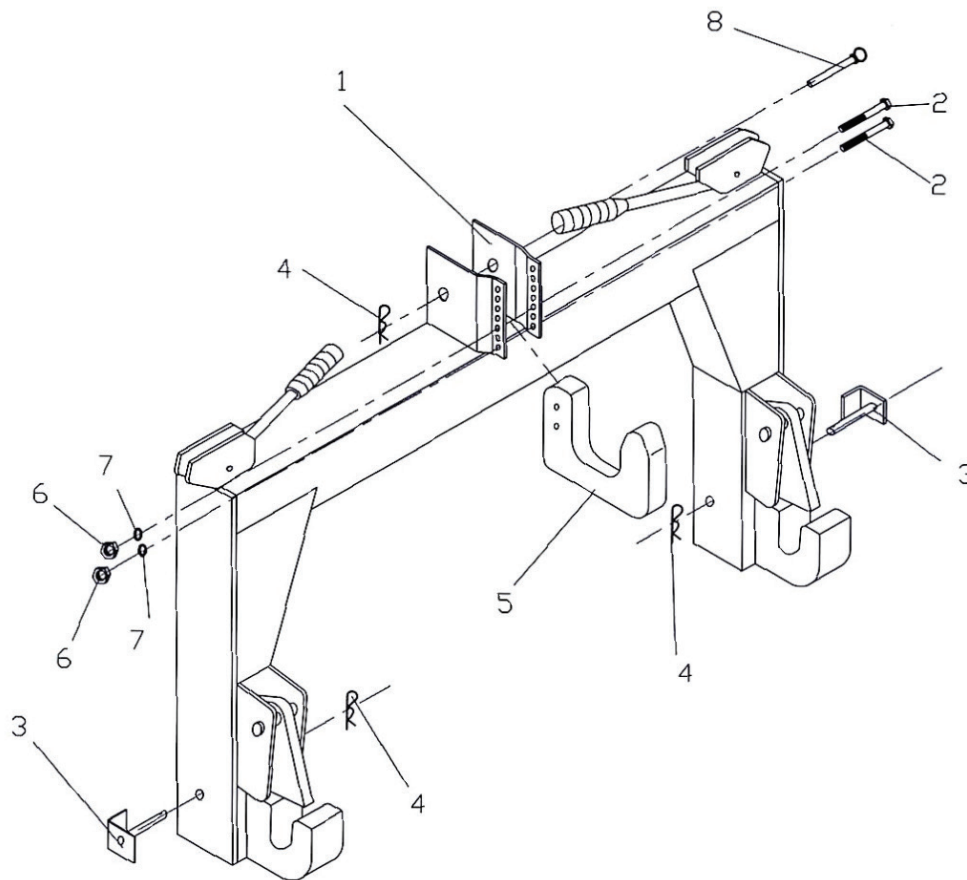

REF	DESCRIPTION	QTY
1	Main Frame Weldment	1
2	Bolt - M12x65	2
3	Lynch Pin	2
4	Hair Pin	3
5	Hook	1
6	Nut - M12	2
7	Lock Washer 12	2
8	Top Link Pin	1



BRABEREQ.COM
WGSALES@BRABEREQ.COM

PHONE: 604-850-7770
FAX: 604-850-7774
TOLL FREE PHONE: 1-877-588-3311
TOLL FREE FAX: 1-800-665-7334