

**HEATED HOLDING****VULCAN****VBP SERIES  
HOLDING & TRANSPORT CABINETS**

Model VBP15



UL Listed. UL Listed to Canadian safety standards.  
Classified by UL to NSF Standard #4.

**SPECIFICATIONS**

Vulcan Hart Model No. VBP heated holding and transport cabinets. Blower motor for gentle and even temperature distribution. Complete with 5" heavy duty casters (2 swivel with brakes and 2 rigid) (VBP5 has 3" casters). Simple knob actuated electronic control for holding at temperatures up to 190°F. Adjustable racking will hold 18" x 26" or 12" x 20" pans or a combination of both on 1½" centers. Lip-load racking will hold 18" x 26" pans on 1½" centers. Shelving will hold a variety of pan sizes. Complete with universal tray slides adjustable on 1½" centers. Cabinet interior and exterior are both constructed out of 20 gauge stainless steel. Recessed side-mounted handles, magnetic action door latch, and full insulation; 1½" in side walls and 2" in top. Integrated steel frame for maximum strength. Field reversible doors. Complete with rear mounted cord and plug: NEMA 5-15 for 120 volts and NEMA 6-15 for 208-240 volts. One year limited parts and labor warranty. After the first year, lifetime parts warranty on the heating elements. ENERGY STAR® qualified (except for model VBP18).

Units with adjustable racking:

- VBP5** (see reverse for capacities)
- VBP7** (see reverse for capacities)
- VBP13** (see reverse for capacities)
- VBP15** (see reverse for capacities)
- VBP18** (see reverse for capacities)

Units with lip-load racking:

- VBP7LL** (Fifteen 18" x 26" x 1" sheet pans)
- VBP15LL** (Thirty 18" x 26" x 1" sheet pans)

Units with shelves:

- VBP7SL** (Three Shelves)
- VBP15SL** (Six Shelves)

**STANDARD FEATURES**

- Holding Capacity:
  - 18" x 26" sheet pans.
  - 12" x 20" pans, or a combination of both on 1½" centers.
  - Other pan sizes on shelves.
- Blower motor for gentle and even temperature distribution.
- Dutch doors (VBP15 and VBP18).
- 5" heavy duty casters (2 swivel with brakes and 2 rigid) (3" on VBP5).
- Recessed side mounted handles.
- Simple knob actuated electronic control for holding at temperatures of up to 190°F.
- Universal tray slides adjustable on 1½" centers. VBP15 & VBP13 ship with 10 pairs of tray slides. VBP7 & VBP5 ships with 5 pairs, VBP18 ships with 15 pairs.
- Interior and the exterior are both constructed out of 20 gauge stainless steel.
- Fully insulated with 1½" in side walls and 2" in top.
- Integrated steel frame for maximum strength.
- Magnetic action door latch.
- Field reversible doors.
- Rear mounted cord.
- Complete with cord and plug: NEMA 5-15 for 120 volts and NEMA 6-15 for 208-240 volts.
- One year limited parts and labor warranty. After the first year, lifetime parts warranty on the heating elements.
- ENERGY STAR® qualified (except for model VBP18).

**OPTIONS**

- 208/240 volt
- Humidity pan
- Full perimeter bumper
- Glass Dutch doors (VBP7 and VBP15 only)
- Wire shelves to sit on tray slides
- Electronic control with digital display (120V only)
- Additional tray slides

**VULCAN**

a division of ITW Food Equipment Group LLC

P.O. Box 696 ■ Louisville, KY 40201 ■ Toll-free: 1-800-814-2028 ■ Local: 502-778-2791 ■ Quote &amp; Order Fax: 1-800-444-0602



**VBP SERIES**  
HOLDING & TRANSPORT CABINETS

Drawings shown with optional bumper

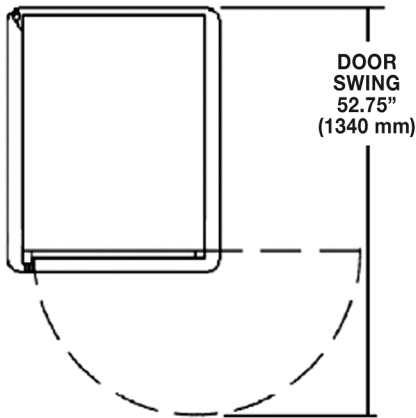

All Models Top View

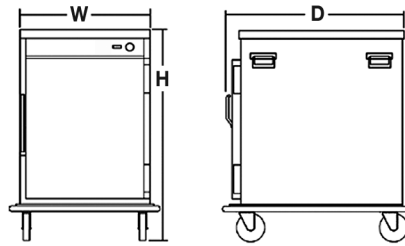

VBP5 Front & Side Views

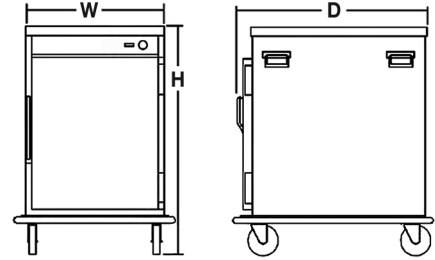

VBP7 Front & Side Views

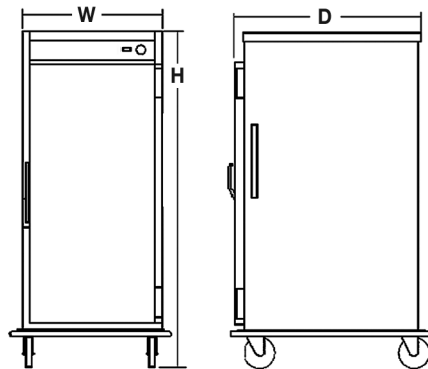

VBP13 Front & Side Views

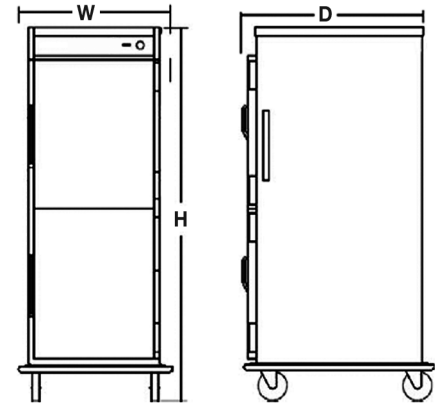

VBP15 & VBP18 Front & Side Views

MODEL	DIMENSIONS	CAPACITY		ELECTRICAL			SHIPPING WEIGHTS	
	EXTERIOR	12" x 20" x 2 1/2" PANS	18" x 26" SHEET PANS	VOLTS	WATTS	AMPS	LBS	KG
VBP5	27 1/4" W x 33" D x 30 1/2" H	10	5	120	1,500	8.3	173	79
VBP7	27 1/4" W x 33" D x 39" H	14	7	120	1,500	8.3	198	90
VBP7LL	27 1/4" W x 33" D x 39" H	NA	15	120	1,500	8.3	198	90
VBP7SL	27 1/4" W x 33" D x 39" H	Unit comes with 3 shelves		120	1,500	8.3	198	90
VBP13	27 1/4" W x 33" D x 59 3/4" H	26	13	120	1,500	10	270	123
VBP15	27 1/4" W x 33" D x 65 1/4" H	30	15	120	1,500	10	297	135
VBP15LL	27 1/4" W x 33" D x 65 1/4" H	NA	30	120	1,500	10	297	135
VBP15SL	27 1/4" W x 33" D x 65 1/4" H	Unit comes with 6 shelves		120	1,500	10	297	135
VBP18	27 1/4" W x 33" D x 73 1/2" H	36	18	120	1,500	12.5	337	153

\*per compartment

Optional bumper adds 3/4" to the width and 1 5/8" to the depth.



a division of ITW Food Equipment Group LLC

P.O. Box 696 ■ Louisville, KY 40201 ■ Toll-free: 1-800-814-2028 ■ Local: 502-778-2791 ■ Quote & Order Fax: 1-800-444-0602

**NOTE:** In line with its policy to continually improve its products, Vulcan reserves the right to change materials and specifications without notice.