

# MST MODELS SPECIFICATIONS

| MODEL                      | MST-28                                | MST-48                                | MST-60                                | MST-72                                |
|----------------------------|---------------------------------------|---------------------------------------|---------------------------------------|---------------------------------------|
| Exterior Dimension (LxDxH) | 27 <sup>1</sup> / <sub>2</sub> x30x37 | 48 <sup>1</sup> / <sub>4</sub> x30x37 | 60 <sup>1</sup> / <sub>4</sub> x30x37 | 72 <sup>5</sup> / <sub>8</sub> x30x37 |
| Cubic Feet                 | 7                                     | 12                                    | 16                                    | 19                                    |
| Compressor (HP)            | 1/3                                   | 1/3                                   | 1/2                                   | 1/2                                   |
| # of Shelves               | 1 ea                                  | 2 ea                                  | 2 ea                                  | 3 ea                                  |
| Net Weight                 | 181 lbs                               | 225 lbs                               | 308 lbs                               | 325 lbs                               |
| Voltage ⓘ NEMA-5-15P       | ⓘ115/60/1                             | ⓘ115/60/1                             | ⓘ115/60/1                             | ⓘ115/60/1                             |
| Amp                        | 6.6 A                                 | 6.5 A                                 | 8.9 A                                 | 9.9 A                                 |
| Cord Length (ft.)          | 9                                     | 9                                     | 9                                     | 9                                     |
| Plug-In                    | NEMA 5-15P                            | NEMA 5-15P                            | NEMA 5-15p                            | NEMA 5-15P                            |
| # of Pans                  | 8 ea                                  | 12 ea                                 | 16 ea                                 | 18 ea                                 |

\*Design and specifications subject to change without notice.

- **SELF-CONTAINED SYSTEM**
- **2.5" CASTERS AVAILABLE FOR ALL MODELS (OPTIONAL)**
- **5" SWIVEL CASTERS**
- **LEGS AVAILABLE FOR ALL MODELS (OPTIONAL)**
- **STANDARD 1/6 SIZE, 4" DEEP CONDIMENT PAN INCLUDED**
- **REMOTE CABINETS AND CONDENSING UNITS AVAILABLE FOR ALL MODELS.**

- **WARRANTY : 1 Year Labor and Parts Warranty  
Additional 4 Years Warranty on Compressor**

(unit : inch)

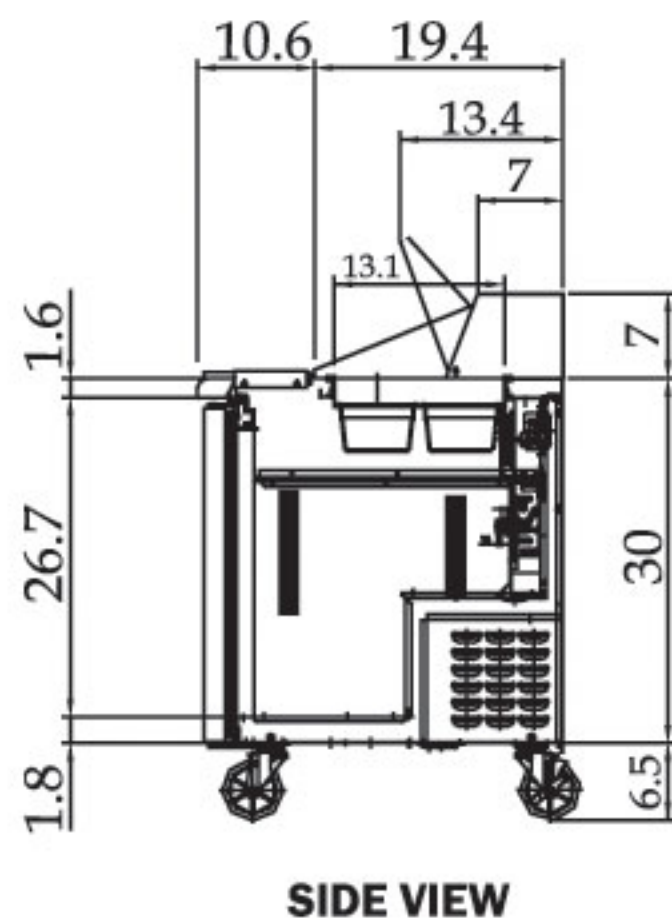

SIDE VIEW

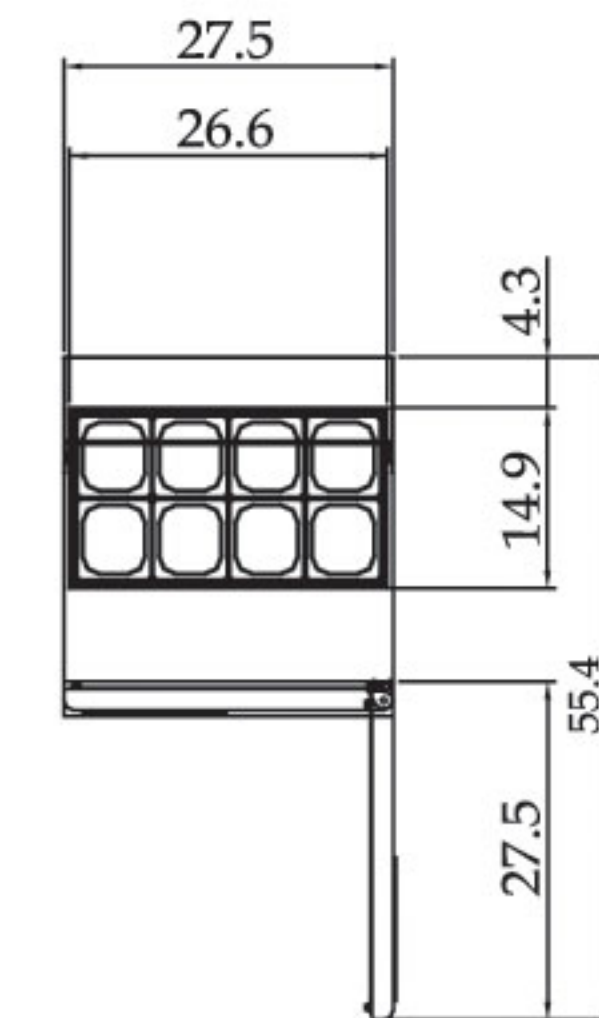

MST-28 PLAN VIEW

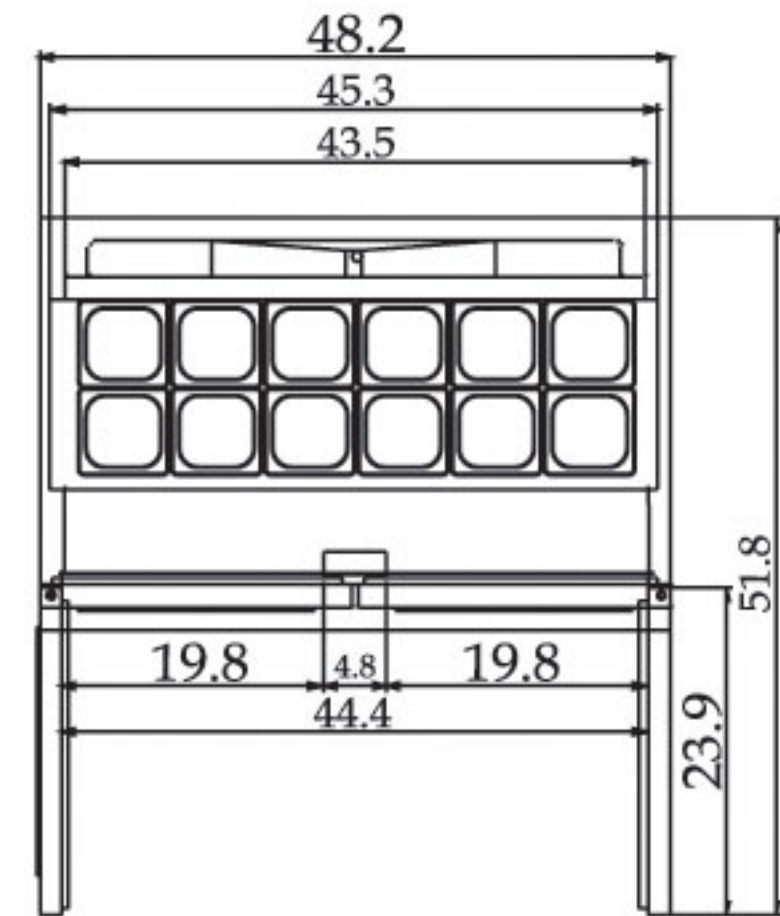

MST-48 PLAN VIEW

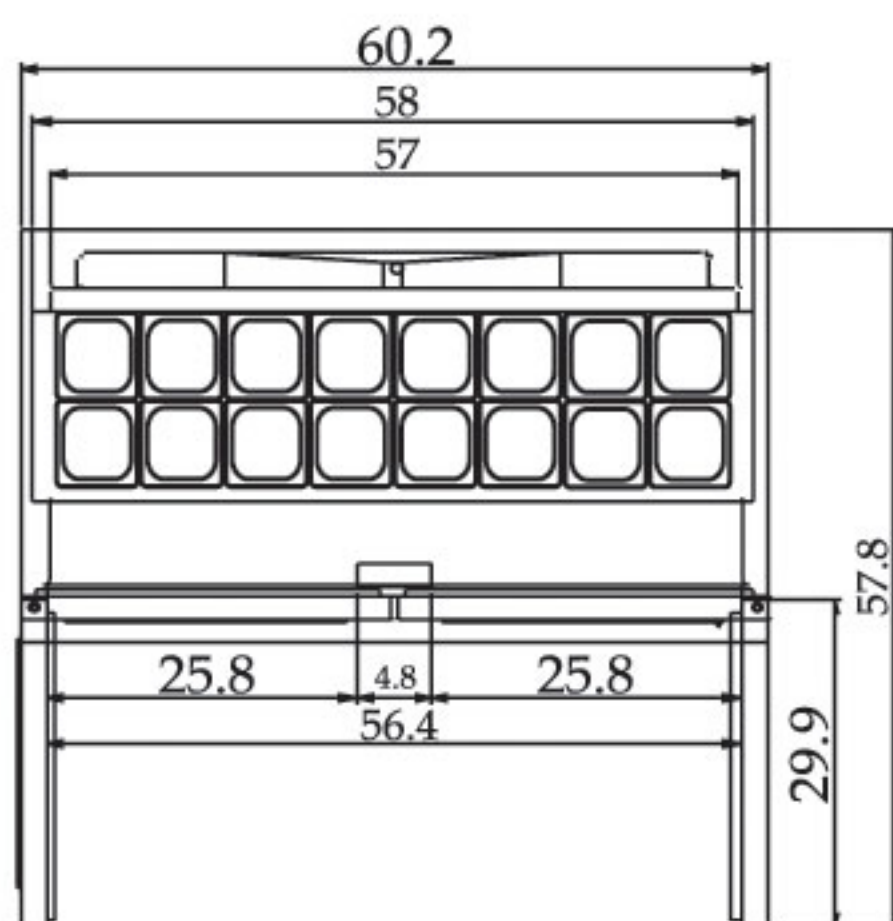

MST-60 PLAN VIEW

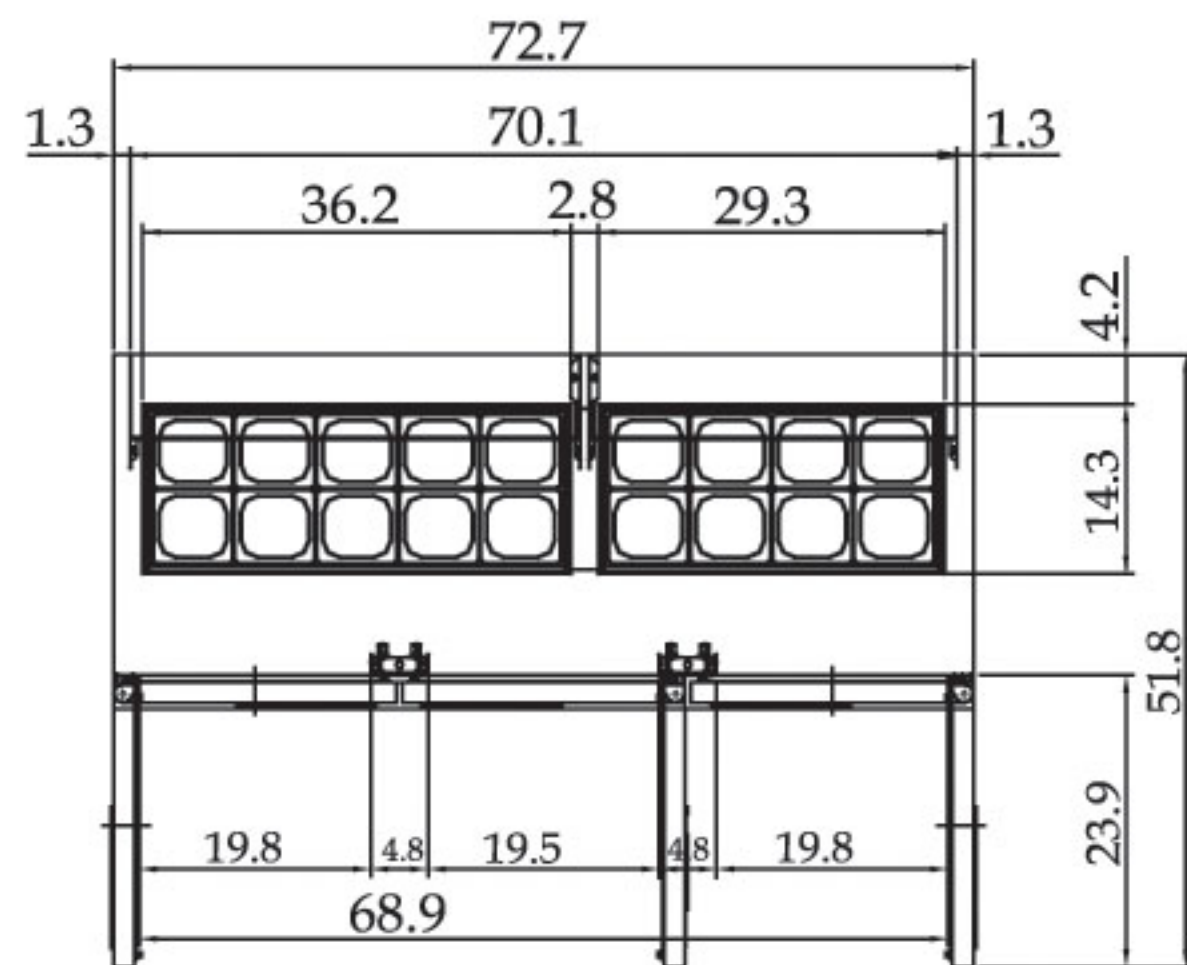

MST-72 PLAN VIEW