

**IS-902**  
**TFI 58-GALLON MIDSHIP**  
**REPLACEMENT TANK FOR**  
**2017-2026 FORD F-250/350**

**TFI PN: 080-01-16565**  
**REV: K REVIEW DATE: 2/3/2026**

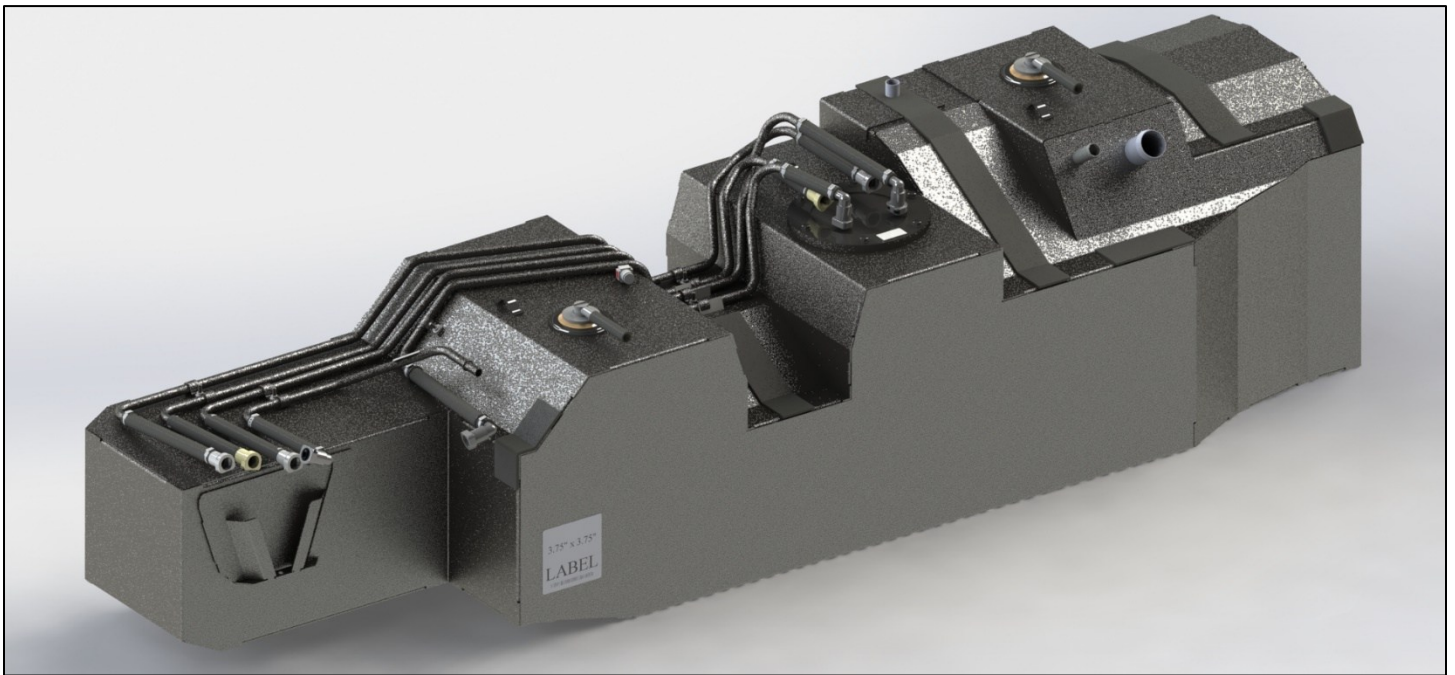

1444 Fortress Street, Chico CA 95973 • 1(800) 442-0056 / (530) 893-5209 • Fax (530) 893-0204  
[www.TransferFlow.com](http://www.TransferFlow.com)

# FOREWORD & LEGAL NOTICE

Thank you for purchasing a Transfer Flow, Inc. 58-gallon replacement fuel system for your 2017-2026 Ford F-250/F-350 diesel pickup. This system will fit any short box Crew Cab, 2x4 or 4x4, diesel vehicle, or any long box Super cab, 2X4 or 4X4 diesel vehicle originally equipped with an OEM 34-gallon fuel tank. Please read the following procedures carefully before starting the installation.

This manual provides the necessary information for the installation of the TFI Fuel System onto your vehicle. All information and instructions contained in this document are based on our annual model year sign off's. We update our instructions sheets based on information obtained during this model year sign-off or/and on information provided by OEM companies and our customers. Changes to installation instructions may be made at any time without notice. If you find something we missed or require any additional information, please feel free to contact us and let us know.

Transfer Flow fuel systems and parts are intended to be used in conjunction with original manufacturer's equipment or Transfer Flow systems and components.

Our systems and components are not intended to be used in conjunction with other after-market fuel systems. Attempting to use our products inappropriately may lead to malfunction and voids the warranty.

This product is protected by state or common law, copyright trademark(s) and/or patent(s). All legal rights therein are reserved. The design, layout, dimensions, geometry, and engineering features shown in this product are the exclusive property of Transfer Flow, Inc. This product may not be copied or duplicated in whole or part, abstractly or fundamentally, intentionally or fortuitously, nor shall any design, dimension, or other information be incorporated into any product or apparatus without prior written consent of Transfer Flow, Inc.

## SAFETY NOTES

Please read these installation instructions entirely prior to beginning the installation of the Transfer Flow fuel system. If you would prefer your fuel system be professionally installed, please contact your local dealer, or browse our list of dealers in your area on our website at [www.TransferFlow.com/installation](http://www.TransferFlow.com/installation).

Transfer Flow fuel systems are designed for use on stock OEM vehicles. We do our best to foresee how our customers will use and modify their vehicles, but unfortunately, we cannot verify all aftermarket modifications. If your vehicle has had any modifications to the chassis, suspension, fuel system, truck bed, or wheel/tire size that differs from stock, please call Transfer Flow before installing one of our fuel systems.

- Work in a well-ventilated area.
- Always wear safety glasses.
- The Transfer Flow fuel tank is heavy, please use proper lifting techniques when handling the tank.



**CAUTION: DO NOT HAVE ANY OPEN FLAME OR HEAT SOURCE CLOSE TO THE INSTALLATION AREA.**



**CAUTION: DO NOT OVERFILL FUEL TANK.**

## **TABLE OF CONTENTS**

FOREWORD & LEGAL NOTICE.....	2
SAFETY NOTES .....	2
TOOLS & SUPPLY REQUIREMENTS.....	4
PARTS LIST/DIAGRAM.....	5
FUEL GAUGE CALIBRATION .....	6
INSTALLATION INSTRUCTIONS .....	7
SECTION 1: REMOVING THE ORIGINAL EQUIPMENT MANUFACTURER (OEM) TANK .....	7
NOTE: OEM BRAKE LINE BRACKET MODIFICATION .....	14
SECTION 2: TFI TANK PREPARATION .....	16
SECTION 3: FUEL WATER SEPERATOR RELOCATION: .....	19
SECTION 4: TFI TANK INSTALLATION: .....	25
NOTE: OEM ROCK SHIELD AND EXTRA HARDWARE.....	28
SECTION 5: FINALIZE THE INSTALLATION: .....	32

# TOOLS & SUPPLY REQUIREMENTS

Before starting the installation process, review the entire installation instructions. If you have any questions regarding the fuel system or the installation process, please contact Transfer Flow, Inc.

## **Tool List:**

- Safety Glasses
- Shop Light
- Ratchets
- 7mm Socket
- 8mm Socket
- 10mm Socket
- 13mm Socket
- 15mm Socket
- 18mm Socket
- Hydraulic Jack
- Torque Wrench
- Face Shield
- Flat Blade Screwdriver
- Hammer
- Rubber Mallet
- 5/16" Socket / wrench
- Ohm Meter
- 15mm open-end box wrench
- ½" Drive, 10" Long Extension
- Torx T-30 bit or wrench (for 2017-2022 Vehicle models)

## **Supplemental Instruction:**

- IS # 484 Torque Specifications

# PARTS LIST/DIAGRAM

Before beginning installation, verify all parts listed below are included in the installation kit. If there are any missing or damaged parts, please contact Transfer Flow, Inc at 1(800) 442-0056.

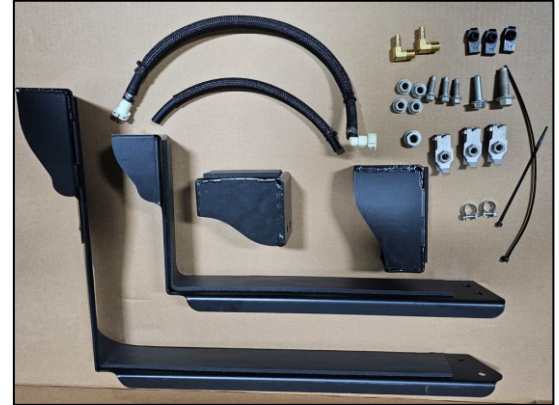
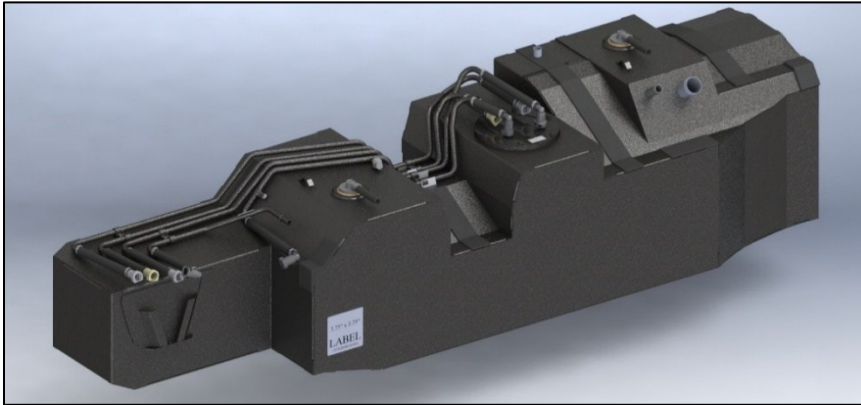

- TFI Ford F-250/350 58-gallon Midship Replacement Tank Assembly (TFI PN: 080-01-16565)
  - TFI Ford F-250/F-350 58-gallon Midship Replacement Tank (TFI PN: 060-0A-16566)
  - TFI Fuel Line Assembly Kit (TFI PN: 020-01-17413)
    - TFI Fuel Supply Line Assembly (TFI PN: 050-01-16573, attached to tank)
    - TFI Fuel Return Line Assembly (TFI PN: 050-01-16574, attached to tank)
    - TFI Fuel/Water Separator Supply Line Assembly (TFI PN: 050-01-16575, attached to tank)
    - TFI Fuel/Water Separator Return Line Assembly (TFI PN: 050-01-16576, attached to tank)
    - TFI Engine/Water Separator Line Assembly 050-01-16584, attached to tank)
    - Two 7/16" roll over vent valve (TFI PN: 070-VA-08013) with short hose attached
  - TFI Installation Kit (TFI PN: 020-01-16568)
    - IS-484 Torque Specifications
    - TFI Tire Loading Weight Sheet (TFI PN: 020-01-13350)
    - Four M10 X 1.5 serrated flange nuts (TFI PN: 070-NU-32028)
    - One M12 X 1.75 flange nut (TFI PN: 070-NU-32030)
    - One M12 X 1.75 X 35mm flange hex bolt (TFI PN: 070-BO-32029)
    - Three M8 X 1.25 X 20mm flange bolt (TFI PN: 070-BO-32031)
    - Two M8 X 1.25 clip nut (TFI PN: 070-NU-34680)
    - One M8 X 1.25 clip nut (TFI PN: 070-NU-34708)
    - Three 6" tie wrap (TFI PN: 070-TI-00439)
    - One 11" tie wrap (TFI PN: 070-TI-00438)
    - One M10 X 1.5 torque prevailing clip nuts (TFI PN: 070-NU-33954)
    - Two 5/16" fuel injection clamp (TFI PN: 070-CL-00162)
    - One 5/16" X 10" cross over hose TFI part number 070-HO-33341 with sleeving
    - Two 5/16" barb X 1/4" MPT elbow brass fitting (TFI PN: 070-FB-00138)
    - 5/16" x 17.5" hose assembly with 1 straight 5/16" fitting and 1 elbow 5/16" fitting
    - 19mm expandable sleeving 10" long (TFI PN: 070-PL-07783)
    - TFI Front/Passenger Side Tank Strap (TFI PN: 040-01-16570)
    - TFI Rear/Passenger Side Tank Strap (TFI PN: 040-01-16571)
    - TFI Front/Driver's Side Strap Bracket (TFI PN: 040-01-16577)
    - TFI Rear/Driver's Side Strap Bracket (TFI PN: 040-01-16583)

# FUEL GAUGE CALIBRATION



Due to the increased capacity of the Transfer Flow replacement fuel system, the vehicle's "Distance to Empty" (DTE) reading will no longer be accurate. The provided table lists the approximate fuel gauge position and fuel volume readings for the Transfer Flow replacement fuel system. These values may vary depending on gauge and sender tolerances.

FUEL GAUGE	FUEL VOLUME [GALLONS]
EMPTY	7
1/4	16
1/2	31
3/4	44
FULL	55

\*Maximum Capacity = 58 Gallons

It has come to the attention of Transfer Flow Inc., (TFI) that early production vehicles equipped with an OEM 34-gallon fuel tank may experience an issue with the distance to empty. Ford [TSB 17-0046](#) states, "Some 2017 F-Super Duty pickups equipped with a 34-gallon fuel tank and built on or before 01-Apr-2017 may exhibit a customer concern that the fuel tank is less than the advertised capacity. This may be due to a greater total reserve than anticipated once the fuel level gauge and/or distance to empty (DTE) message indicates the fuel tank is empty". If your vehicle was manufactured during the date range listed in the TSB, contact Ford prior to installing the TFI midship replacement fuel system. The repair may include a new OEM fuel pump sending unit and fuel tank.

Any vehicles that experience the condition described in the Ford TSB will continue to experience the same condition with the TFI replacement fuel system. Due to the larger bottom surface area of the TFI fuel tank, the condition described in TSB 17-0046 may be magnified by the TFI replacement fuel system. Meaning that if installed, the TFI fuel system will continue to have "greater total reserve than anticipated" until the affected vehicle is repaired.

If you are unsure if your particular vehicle is covered under TSB 17-0046, please contact your Ford dealer for further details *PRIOR* to the installation of the TFI midship replacement fuel system. If the TFI fuel system is installed in a vehicle covered under the TSB prior to any necessary repairs the DTE could be off by as much as 8 gallons!

# INSTALLATION INSTRUCTIONS

## SECTION 1: REMOVING THE ORIGINAL EQUIPMENT MANUFACTURER (OEM) TANK

1. Disconnect the battery cables.
2. Using an 8mm socket and ratchet or wrench, loosen the clamps securing the fill hose and vent hose to the OEM tank from the fill pipe. Remove the fill and vent hoses from the OEM fill tubes.



3. Remove the OEM rock shield. Retain all hardware as some hardware will be re-used to install the TFI replacement tank. If no rock shield is installed, then use the provided hardware during the replacement tank installation.
  - a. Spray all rock shield mounting hardware with WD-40 or similar lubricant to prevent the clip nuts from breaking. Do not use an impact gun to remove the rock shield bolts, as this can also damage the clip nuts. After allowing the lubricant to soak for a few minutes, use a 13mm socket, socket drive and appropriate socket extensions to remove the 6 rock shield mounting bolts.
  - b. Remove and retain the two bolts securing the rock shield at the front/driver's side of the fuel tank. Do not remove the OEM clip nuts. If no OEM rock shield was installed, then install two of the provided M8 clip nuts.
  - c. Remove and discard the bolt from the front/passenger side of the rock shield.
  - d. Remove and discard the bolt from the rear/driver's side of the rock shield.
  - e. Remove the two bolts from the rear/passenger side of the rock shield. Retain one bolt for installing the replacement fuel system.

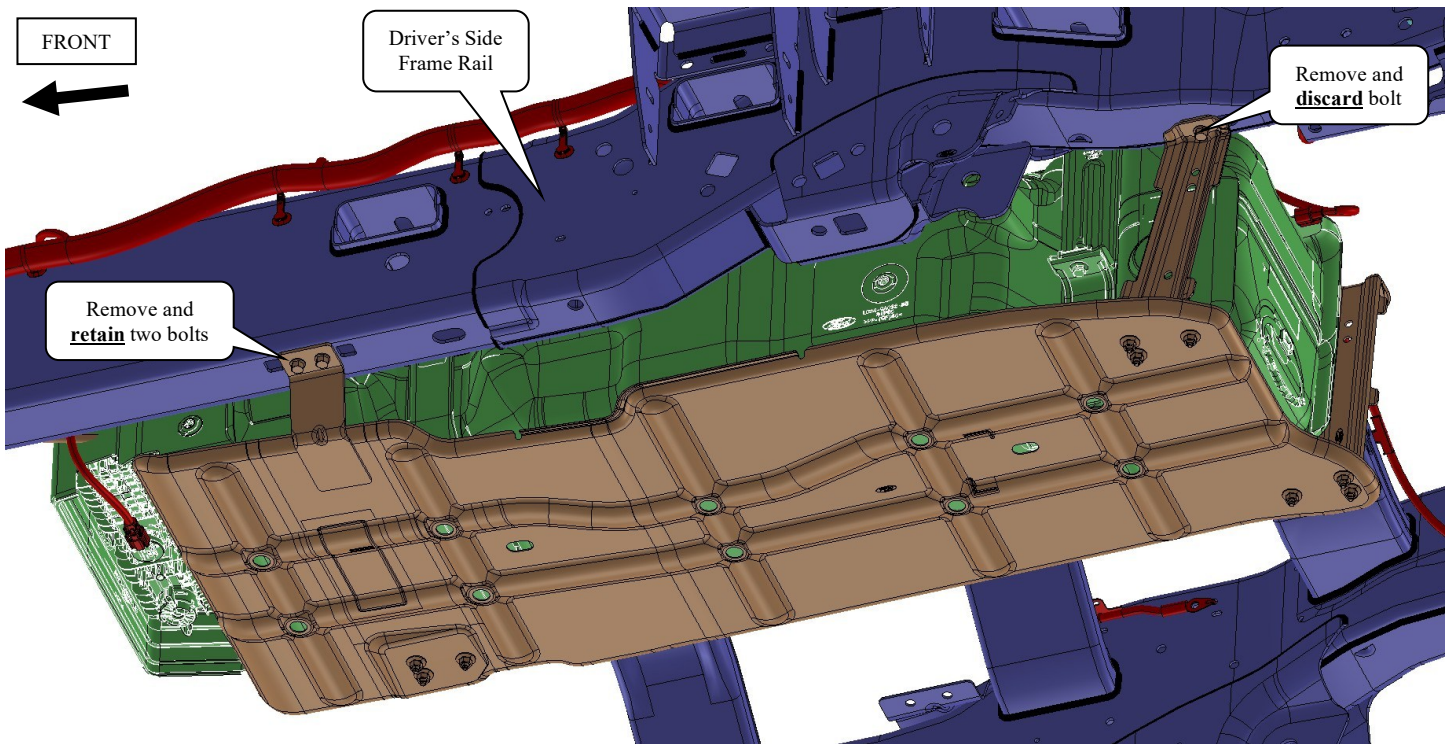
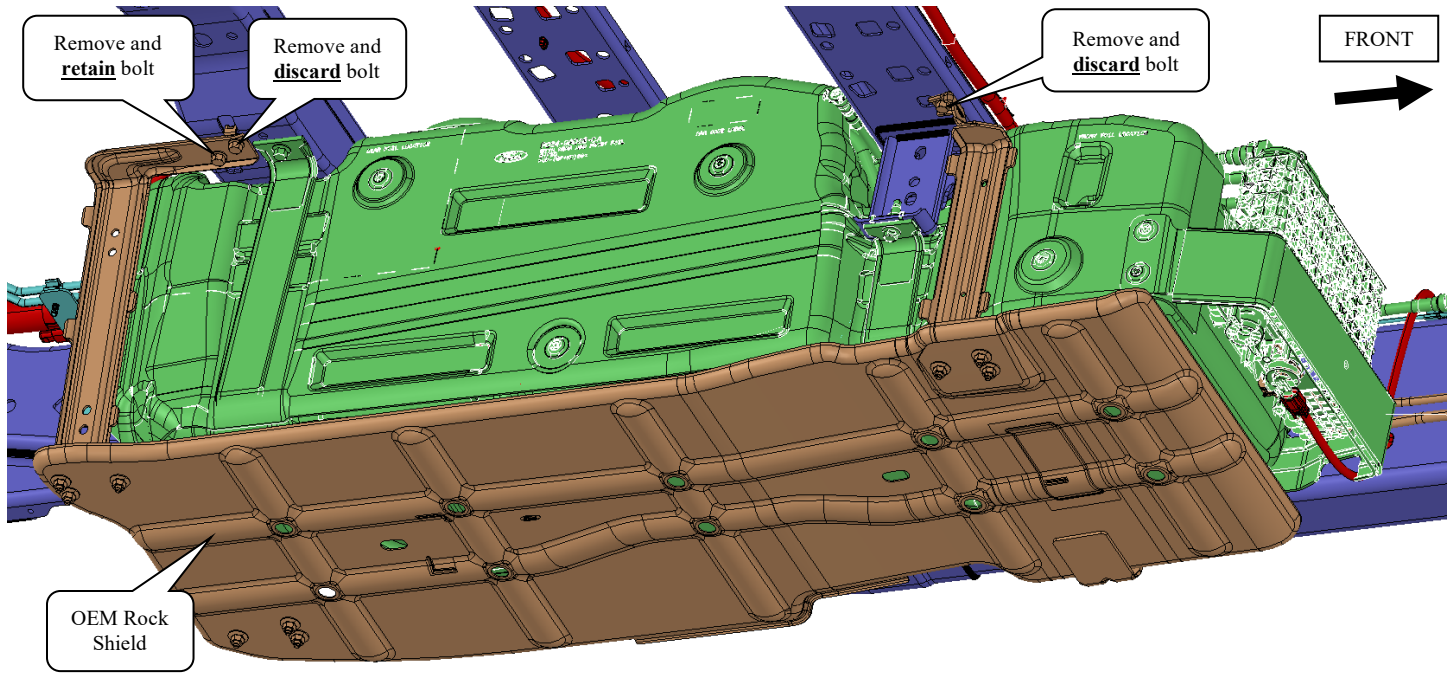

4. Place a hydraulic jack underneath the OEM midship fuel tank. Raise the jack until contact with the tank is made.



**OEM fuel supply and return fitting latching tabs can be easily broken. Review the disassembly procedure before trying to disconnect these fittings. Do not drop the tank any lower than allowed by the OEM fuel supply and return lines. Plastic fuel lines are not designed for large movement. Fuel may be under pressure and may leak from these disconnected fuel lines. Keep the open ends away from any heat source, and place a drip pan beneath them.**

5. ***2023 – Present Vehicle Models ONLY***: Disconnect the fitting from the exhaust/fuel tube along the middle crossmember and above the fuel tank. Pull the locking clip to release the lock. Push the fitting towards the tube, press and hold the green clip, then pull the fitting away from the tube to disconnect.

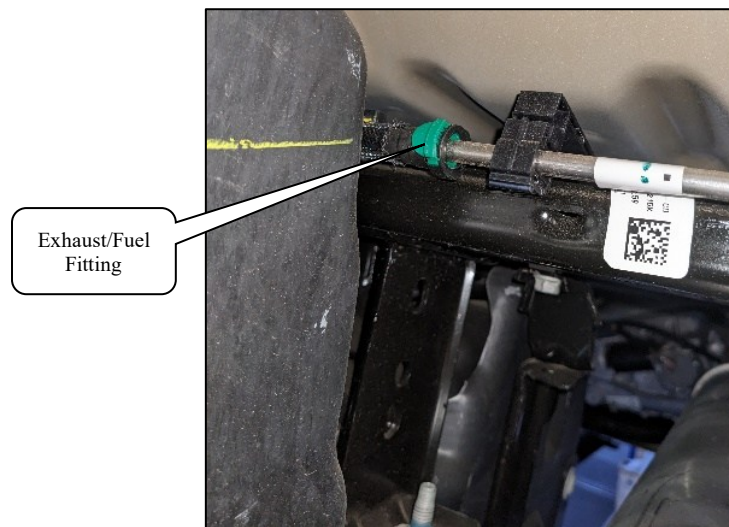

6. Disconnect the fuel supply and return line fittings at the front of the tank.
  - a. Unlock the fitting attached to the top of the water separator/fuel filter, then disconnect the Fuel Return fitting.
  - b. Carefully unlock the locking tab on the fuel supply line fitting located at the front of the fuel tank and along the driver's side frame rail. An o-ring pick or small flathead screwdriver can be used to aid in moving the lock. Do not pry on the locking tab, as it is fragile and will easily break.

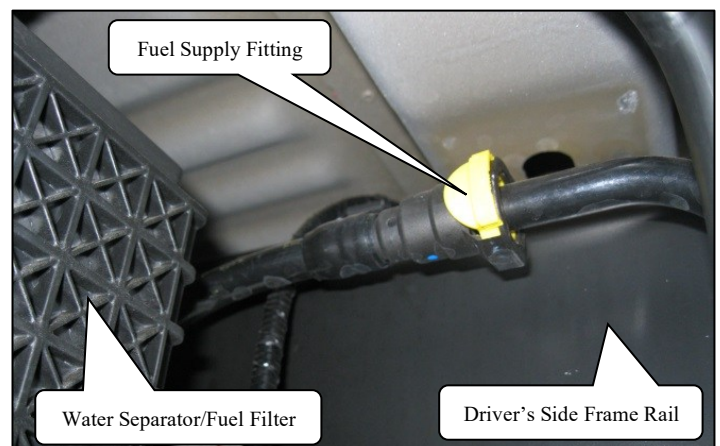
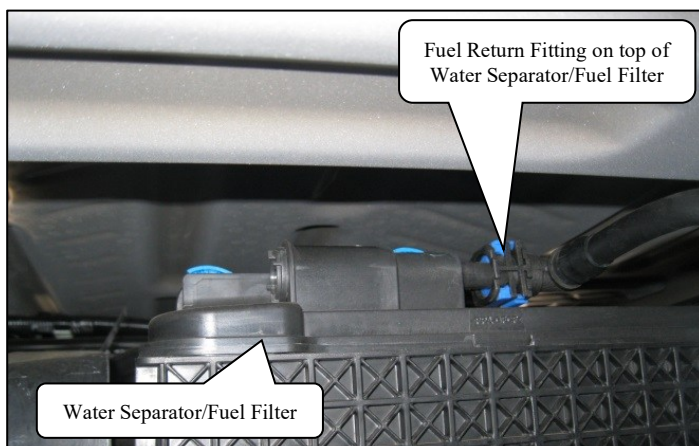

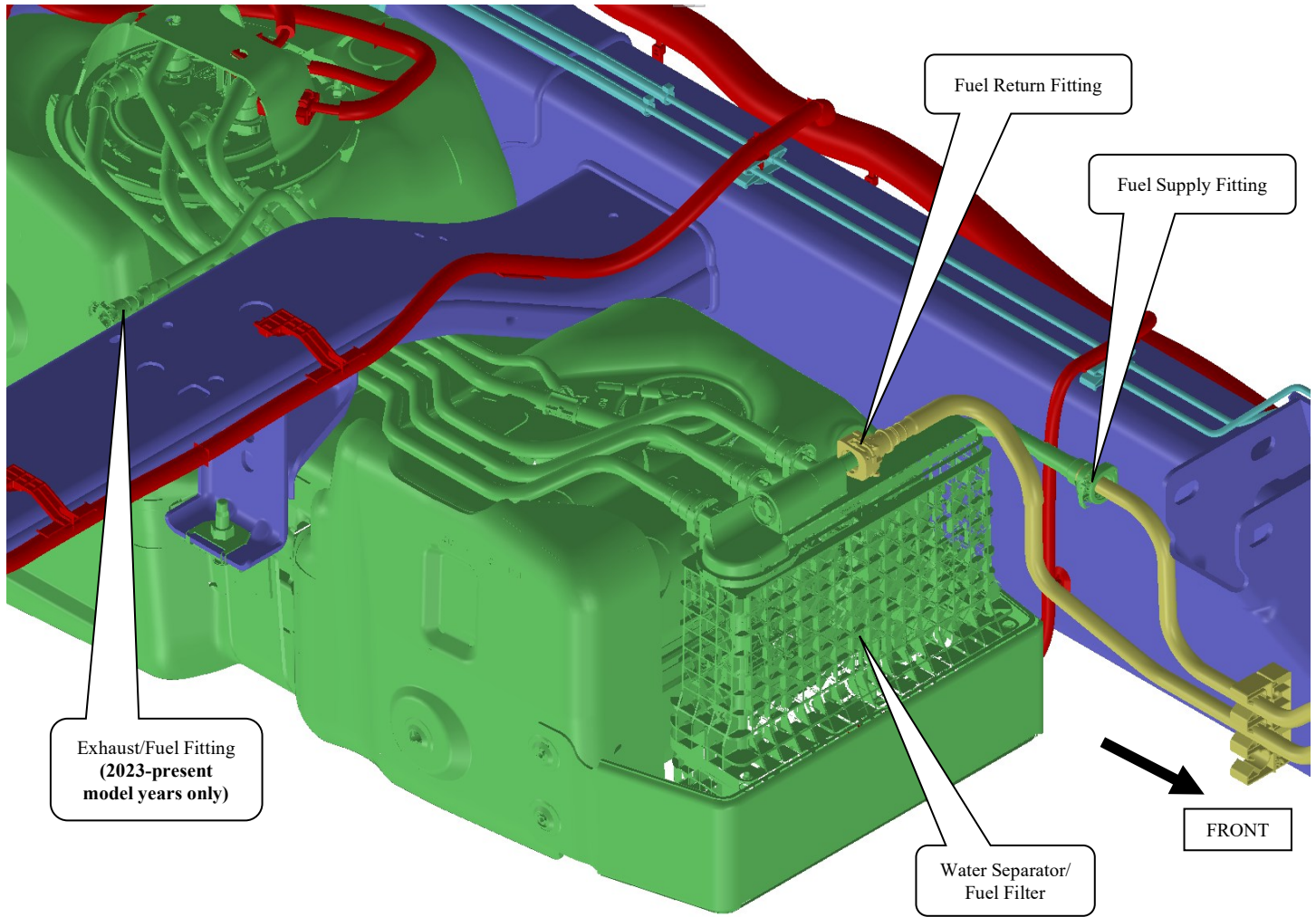

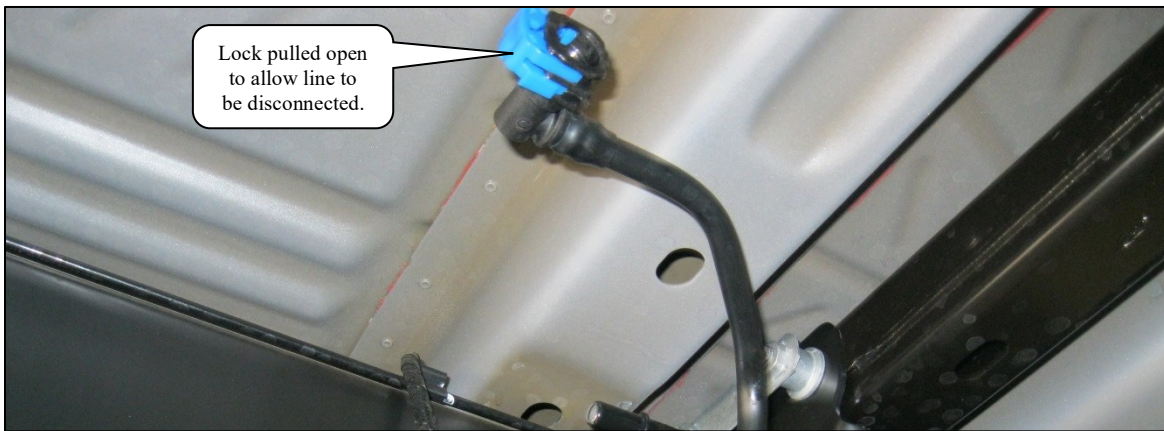

7. An electrical connector on the bottom of the OEM fuel filter will need to be removed. Depress the locking tab on the connector and pull the connector to remove it from the fuel filter.

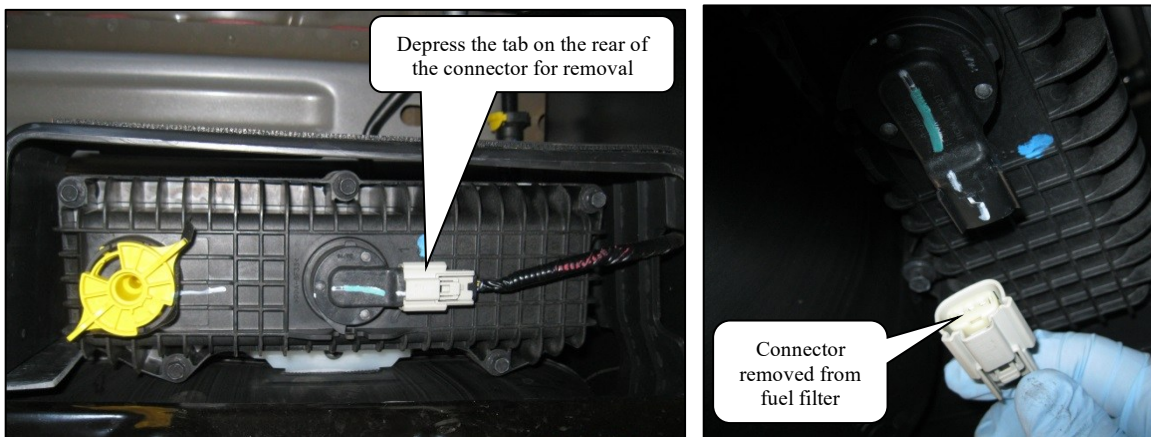

8. Remove the front fuel tank strap.
- Spray front fuel tank strap mounting hardware with WD-40 or similar lubricant to prevent the clip nuts from breaking. Do not use an impact gun to remove the fuel tank strap bolts, as this can also damage the clip nuts. After allowing the lubricant to soak for a few minutes, use a 13mm socket, socket drive and appropriate socket extensions to remove the fuel tank strap bolts.
  - Remove and discard the bolt from the front/driver's side of the fuel tank.
  - Remove and discard the bolt and clip nut from the front/passenger side of the fuel tank.
9. Remove the rear fuel tank strap.
- Spray rear fuel tank strap mounting hardware with WD-40 or similar lubricant to prevent the clip nuts from breaking. Do not use an impact gun to remove the fuel tank strap bolts, as this can also damage the clip nuts. After allowing the lubricant to soak for a few minutes, use a 13mm socket, socket drive and appropriate socket extensions to remove the fuel tank strap bolts.
  - Remove and discard the bolt from the rear/driver's side of the fuel tank. If needed, the clip nut can be accessed through the end of the crossmember (outside of frame rail) and held with a 15mm wrench.
  - Remove and retain the rear/passenger side (long) bolt. The OEM hardware will be re-used to install the replacement fuel system.

Driver's Side View - Frame Rail hidden for clarity

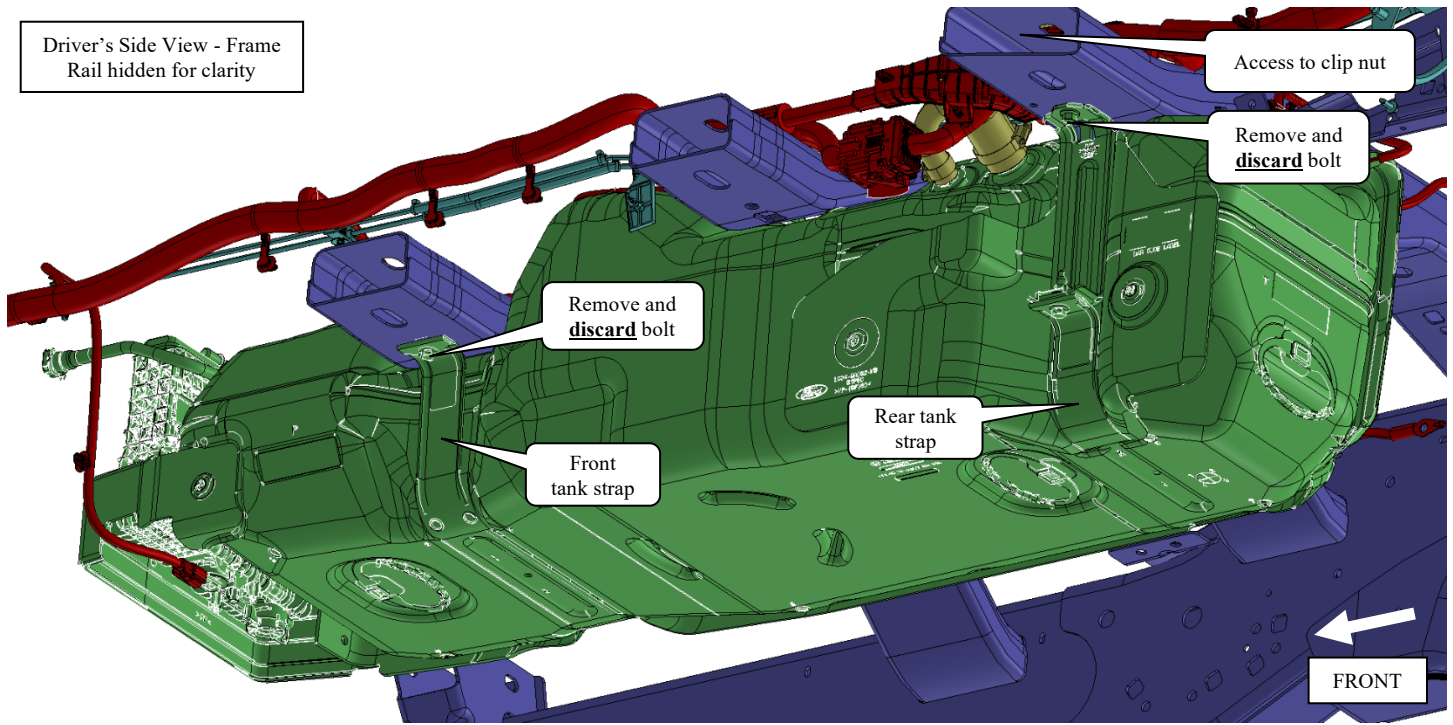

Rear tank strap

Remove and retain bolt

Remove and discard bolt

Front tank strap

FRONT



Passenger Side View

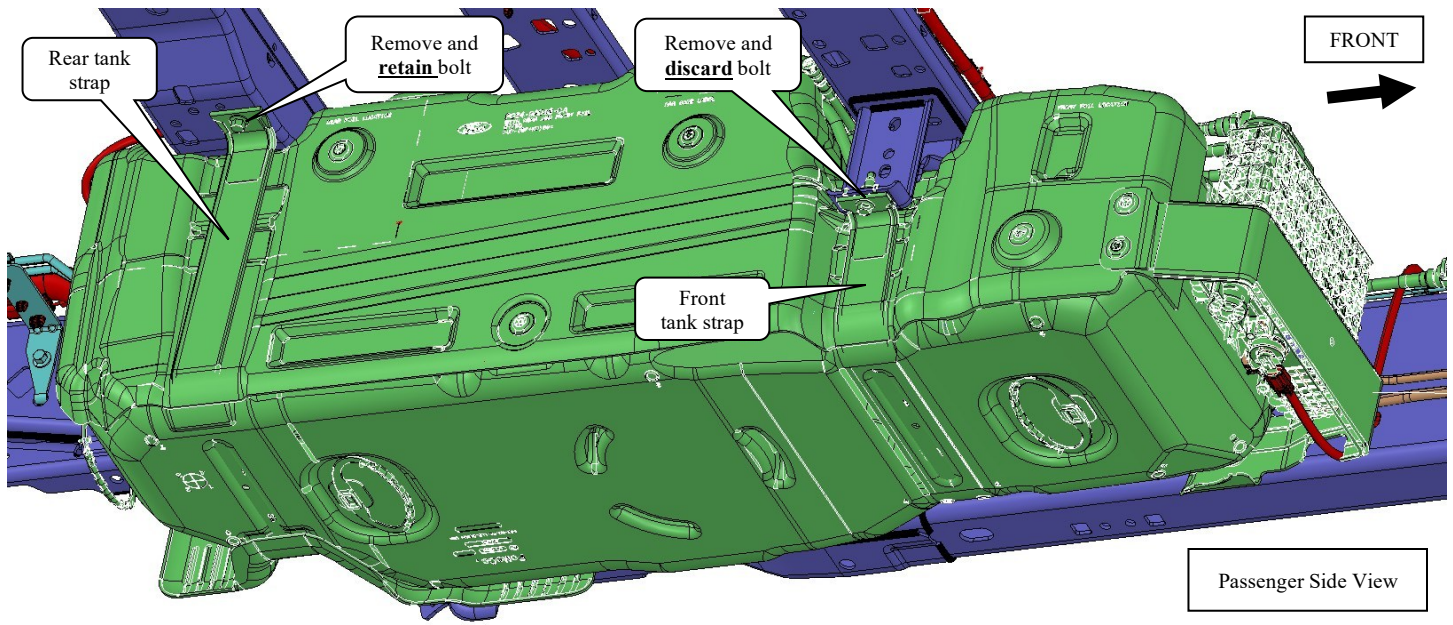

10. Lower the OEM midship tank approximately 2" or until you have complete access to the OEM sending unit without compromising electrical connection on the sending unit. The sending unit can be accessed by reaching over the driver's side frame rail and in front of the rear cab mount.



11. With the tank lowered slightly the tab that retains the electrical connection to the sending unit can be depressed allowing the electrical connection to be removed from the sending unit. Depress the tab and pull on the connector to remove it from the sending unit. **DO NOT** pull on the wires that go to the connector. Doing so can potentially pull the wires out of the connector and render them inoperative.

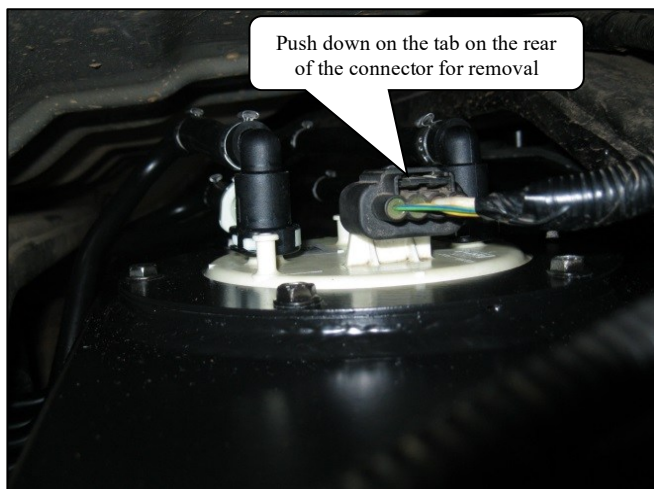

12. With the rock shield removed, straps unbolted, the fuel lines disconnected, the electrical connection on the fuel filter disconnected, the sending unit electrical connection disconnected, and the fill and vent hoses disconnected, you are now ready to carefully lower the OEM fuel tank. Take care that the fuel lines or electrical connections do not catch on to anything while the tank is slowly being lowered.
13. Once the OEM fuel tank is lowered, completely remove the OEM fuel tank out of the vehicle.

## **NOTE: OEM BRAKE LINE BRACKET MODIFICATION**

- If the vehicle is **NOT** equipped with the brake line support bracket, then skip to the next section.
- If the vehicle is equipped with a plastic brake line support bracket as shown below, then it should be modified to avoid contact with the replacement fuel system.
  - o Carefully remove the brake line support bracket using a trim removal tool or pliers, making sure to not bend or puncture the steel brake lines.
  - o Cut the bracket at the noted location, as shown below.
  - o Reinstall the bracket onto the brake lines in the original location but install the bracket such that the flat side is pointing down.

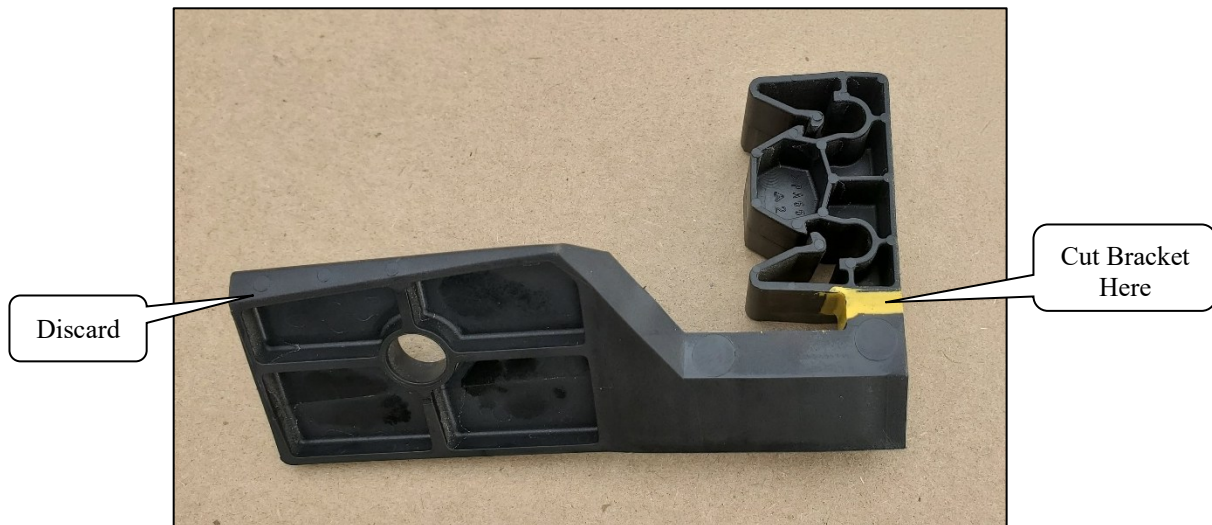
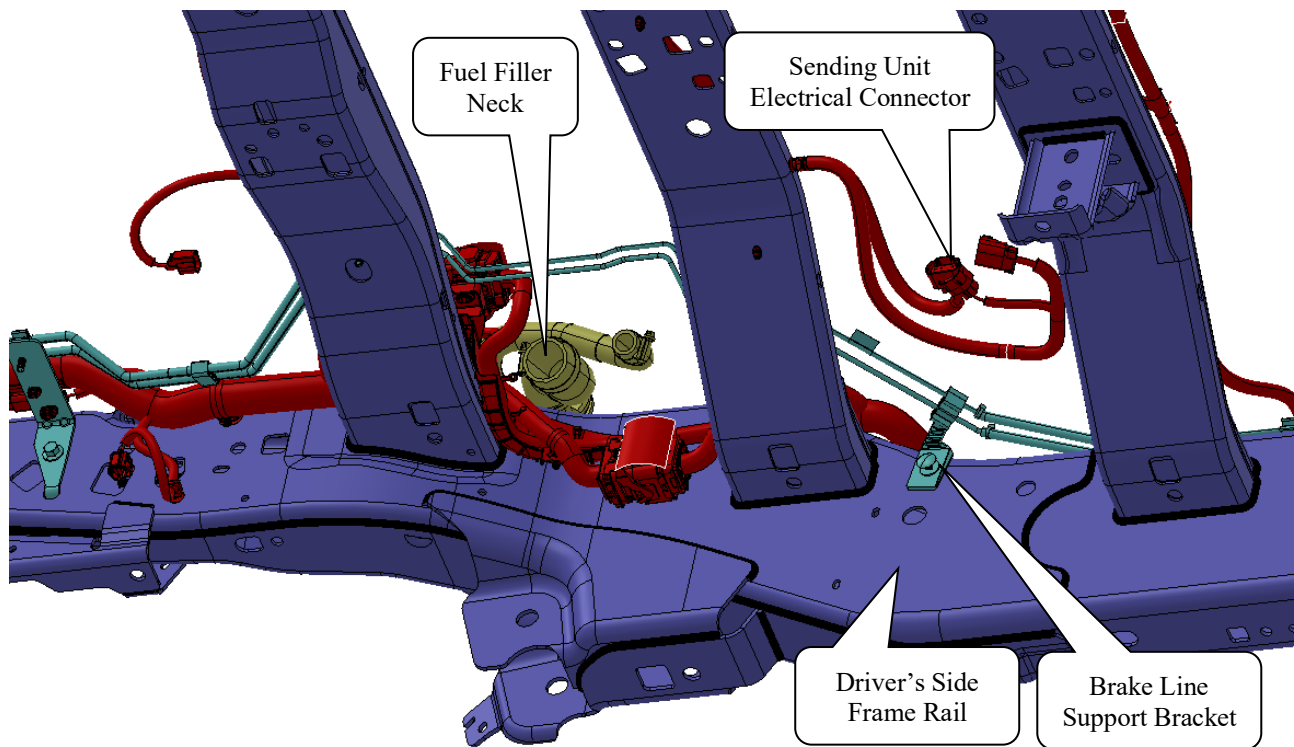

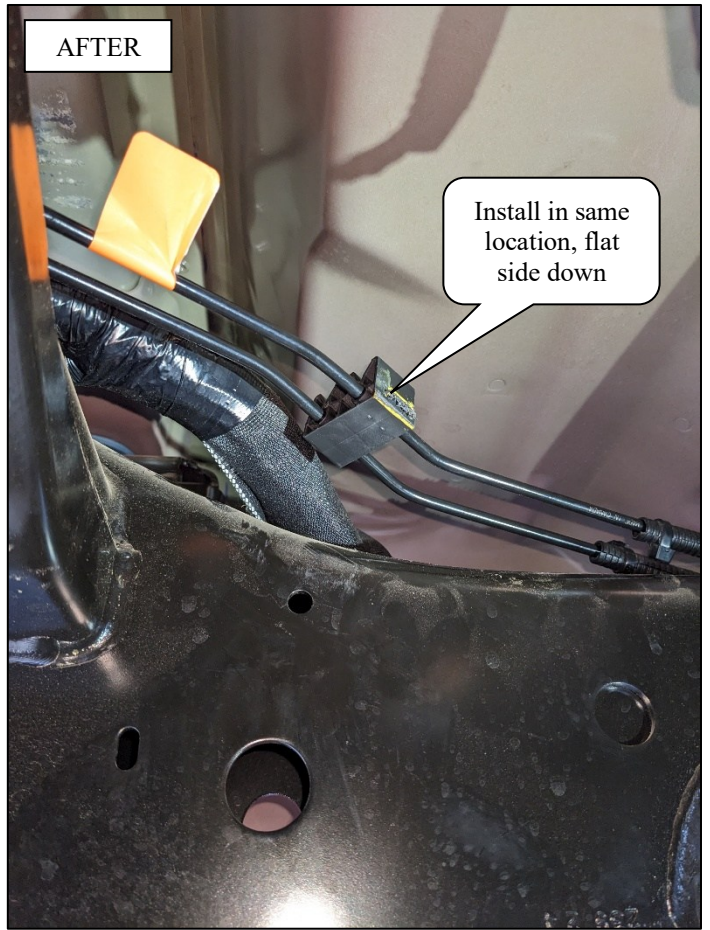
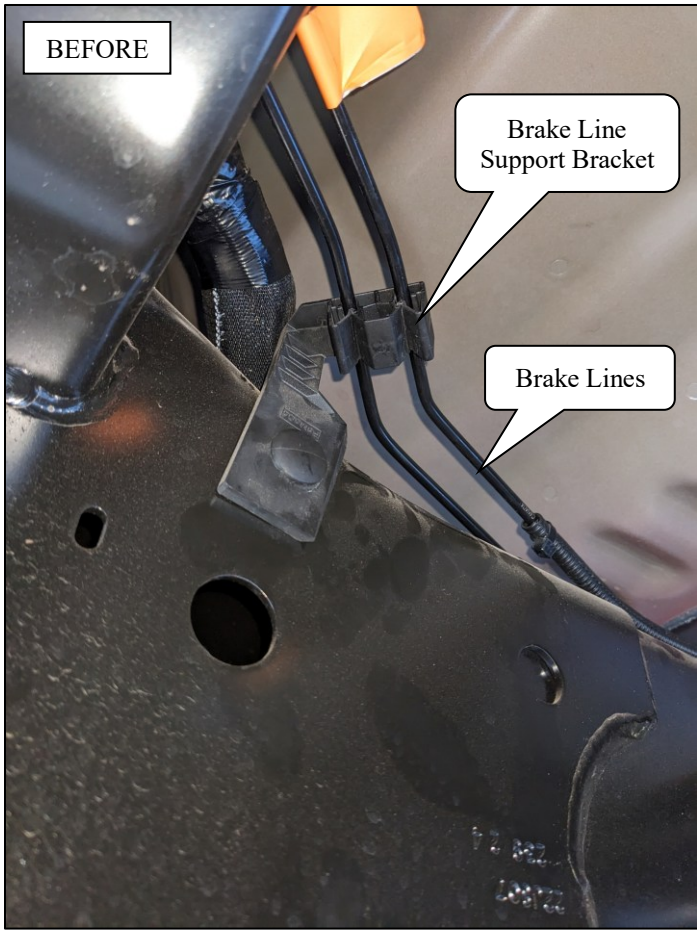

## SECTION 2: TFI TANK PREPARATION

14. With the OEM fuel tank out of the vehicle, you will notice that there are four fuel lines coming from under a cover on top of the OEM pump sending unit. These lines will **NOT** be retained with the TFI fuel system. There are four similar lines on top of the TFI fuel system that will perform the same function as the OEM lines.
15. In order to remove the OEM pump sending unit from the OEM fuel tank, the sending unit cover will need to be removed. The sending unit cover is secured with three nuts that require removal using a 10-mm socket to access the fuel supply and return lines. In the following picture you can see the sending unit cover on the tank once it has been removed from the vehicle. Remove the cover and discard, it will not be used on the TFI fuel system.

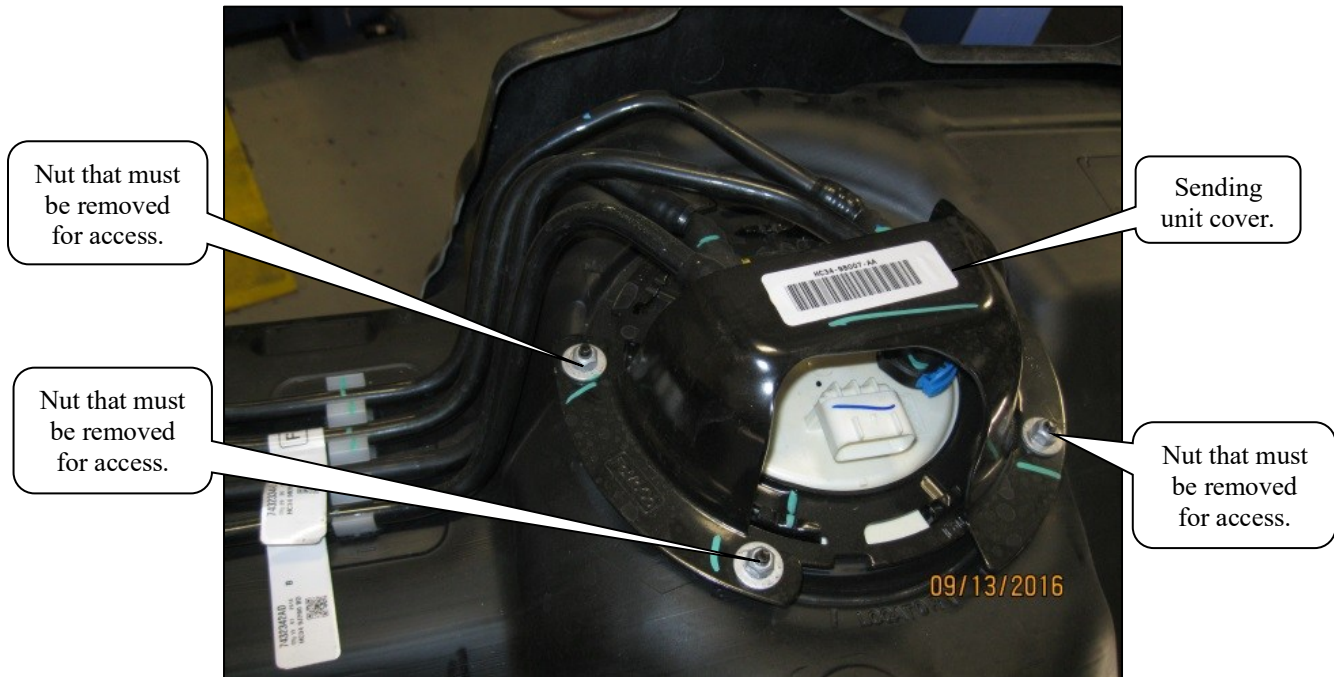

16. There are four fuel lines attached to the OEM pump sending unit. Open the locks on the fuel lines as previously outlined and remove the fuel line connectors from the top of the pump sending unit.
17. For ease in removing the pump sending unit, remove the four fuel lines from the molded bracket that attaches them to the OEM fuel tank near the pump sending unit.
18. Using a flat blade screwdriver and hammer, remove the cam ring from the OEM fuel tank, discard the OEM cam ring. Remove the OEM pump sending unit from the tank. Take care as the pump sending unit will be full of fuel. As you turn the pump sending unit to clear the float wire, pour the fuel out of the sending unit sump back into the OEM fuel tank.
19. With the sending unit on a flat and level surface attach an ohm meter to the sending unit on the two left pins. Measure the ohm reading of the sending unit with the OEM float wire at empty (float all the way down) while resting on a flat level surface. Record the value here \_\_\_\_\_ $\Omega$  at empty. Typical ohm values at empty are 175 $\Omega$  to 185 $\Omega$ .

20. Perform the same test with the float all the way at the top in the full position and record the value here \_\_\_\_\_  $\Omega$  at full. Typical ohm values at full are  $7\Omega$  to  $14\Omega$ .



21. Using a 10mm socket, remove the (6) M6 bolts from the TFI sending unit compression ring. Remove and discard the TFI sending unit ring cover. The bolts will be reused to install the sending unit into the replacement tank.
22. Confirm that the surface the sender gasket will rest on is clean and dirt free. Clean any dirt or other debris with a damp rag. Place the sender gasket in the groove on the TFI fuel tank at the sender opening.
23. Carefully position the OEM sending unit on top of the gasket. Orient the OEM sending unit, so the large locating tab falls into the machined pocket on the TFI sender ring. The OEM sending unit will only fit one way.



Align the locating tab on the pump sending unit with the pocket in the TFI sender ring.

24. While holding down the sending unit in position, install the TFI compression ring and (6) M6 bolts that were previously removed from the TFI tank. Use a 10mm wrench or socket to tighten the hardware. Refer to Instruction Sheet #484 for proper torque specifications.
25. Reattach the ohm meter leads to the sending unit. With the tank resting on level ground, positioned as if it were in the vehicle, the resistance reading should be close to the ohms reading previously recorded at empty. Turn the tank upside down so the float arm will fall into the full position. The resistance meter should once again read close to the previously recorded value for full. This step will ensure that the gauge reading is correct once the tank is installed.

26. Attach the four TFI fuel lines to the corresponding locations on the OEM pump sending unit. The fittings are a combination of ½" and 12mm, straight and 90° fittings that can only go onto the pump sending unit one way correctly. Once each connection is made, gently pull on the connector to be sure it is locked onto the pump sending unit and will not come off during operation.

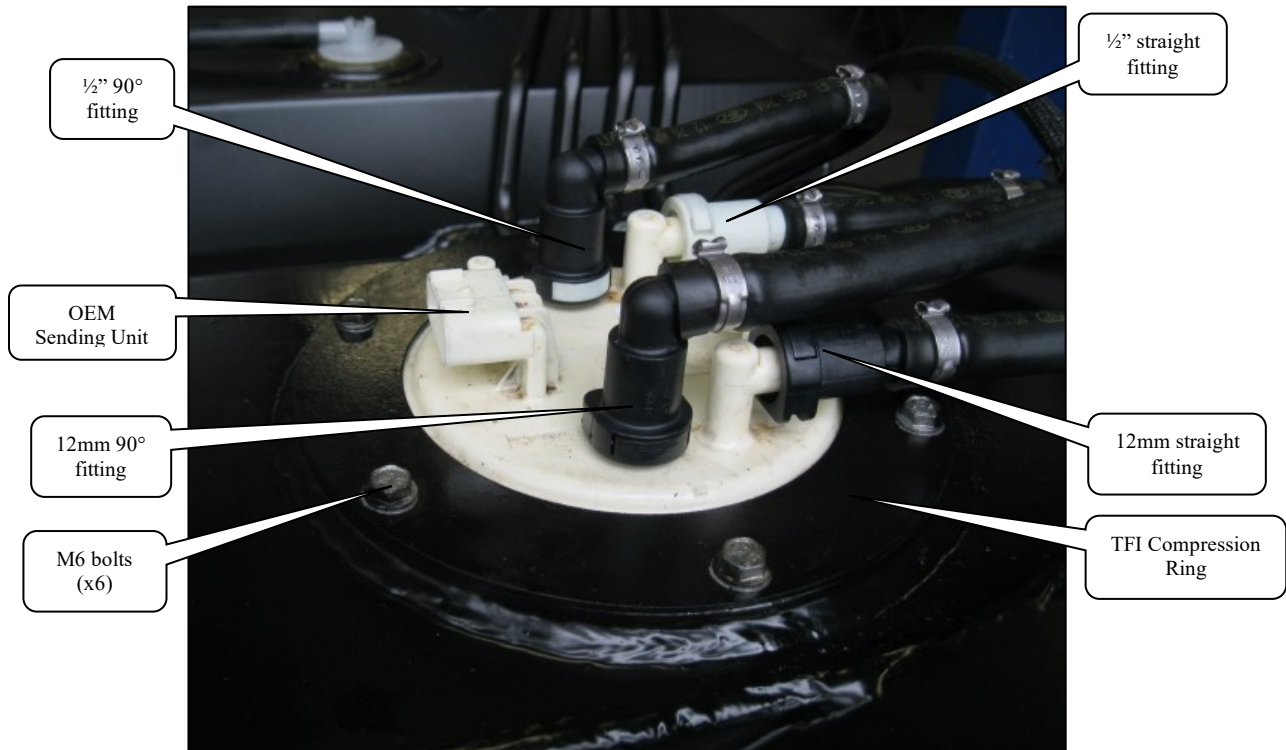

## **SECTION 3: FUEL WATER SEPERATOR RELOCATION:**

27. There is a fuel / water separation filter attached to the front of the OEM fuel tank. You must relocate the separator to the TFI fuel tank to allow installation of the TFI larger capacity midship replacement fuel tank. To facilitate relocation of the OEM separator, there is a bracket welded to the TFI fuel tank that the OEM separator needs to be mounted onto. Please read and understand the following steps completely before proceeding.
28. **2017-2022 Vehicle Models:** Using a T-30 Torx bit on an extension with a ratchet or a Torx screwdriver, remove the Torx head screw in the bottom of the fuel / water separator filter that attaches the filter to the bracket molded into the front of the OEM fuel tank. Retain the screw as it will be used to mount the filter to the bracket on the TFI 58-gallon midship replacement fuel tank.

**2023 – Present Vehicle Models ONLY:** Use an 8mm socket with extension and ratchet to remove the screw from the bottom of the water separator filter. Keep this screw for securing the filter to the 58-gallon midship replacement fuel tank.

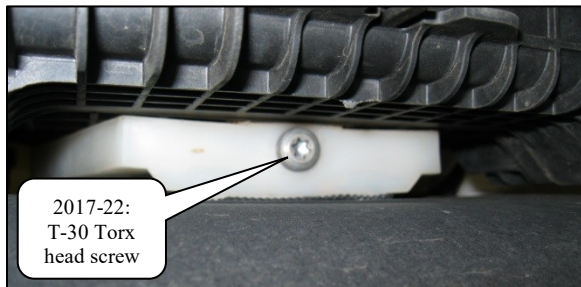

29. Place a catch pan under the fuel filter and remove the three OEM fuel lines that run on top of the tank between the fuel / water separator and the OEM pump sending unit by manipulating the locking tabs as you did previously and pull the connectors away from the filter.

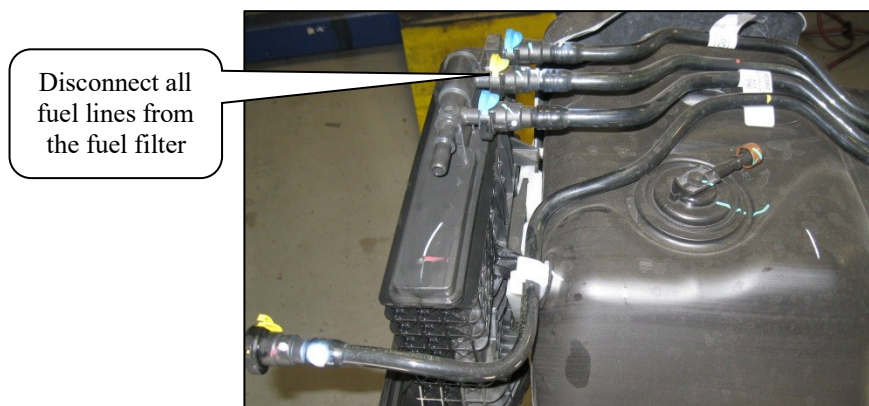

30. Remove the fuel filter by pulling it upward, away from the OEM fuel tank. It may be necessary to use a rubber mallet to tap the fuel filter upward away from the mounting bracket on the OEM fuel tank. There is a pocket molded into the filter mounting bracket that part of the fuel filter housing latches into when it is secured to the OEM fuel tank. Once the filter is clear of this pocket it will come free easily.
31. Take care as you handle the filter, it is still full of fuel and when turned out of position the fuel will drain out of the filter housing. For ease, the filter should be slowly turned over while in a catch pan to drain out the fuel prior to installation on the TFI fuel tank.

32. Once removed, you will notice that the OEM plastic filter mount is a “V” that the filter slides down into and is secured with the OEM screw removed previously. The TFI filter mount is similar in design to the OEM in that it is a “V” that the filter slides down into and is secured using the same OEM screw.

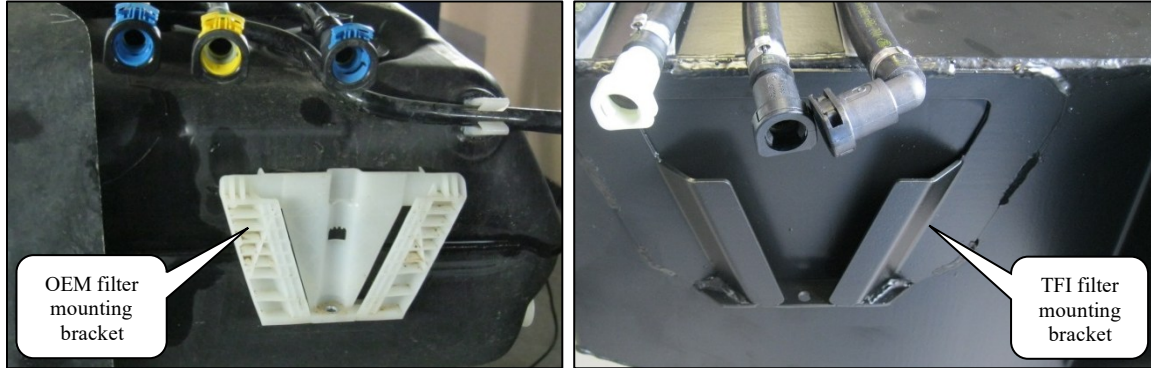

33. Install the OEM filter onto the TFI tank in the filter bracket mounted on the TFI fuel tank by sliding the filter down into the “V” bracket from the top. Place the OEM screw that has M6 X 1.0 threads through the hole in the bottom of the TFI filter bracket and start threading it into the OEM filter housing. Secure the filter with the OEM screw and refer to Instruction Sheet #484 for proper torque specifications.

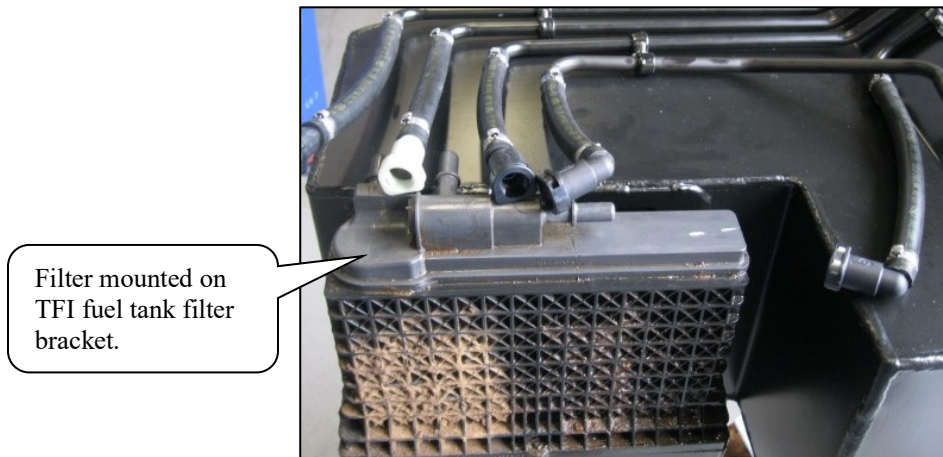

34. Like the fuel lines on the Pump Sending Unit, the fittings that attach to the fuel / water separator filter are a mixture of ½” and 12mm that can only be connected one way correctly. Connect the lines to the fuel filter appropriately. After each connection is made, gently pull on the connector to be sure it is locked onto the fuel/water separator and will not come off during operation.

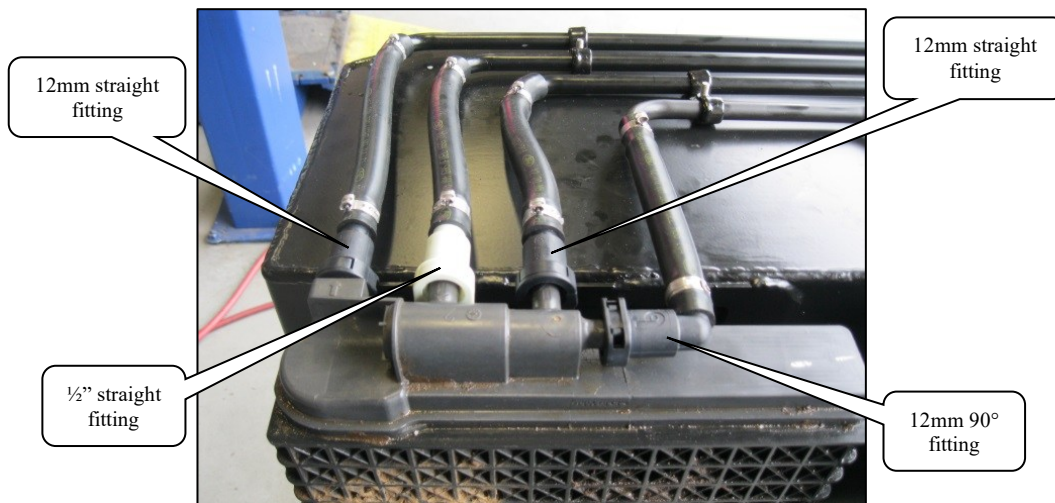

35. **2023 – Present Vehicles ONLY:** Remove the 5/16" fuel cap from the return fuel line spout. Use the 5/16" fuel hose from kit 020-01-16568 and connect the 90° elbow fitting to the tube. This line will be placed over the middle crossmember and connected to the 5/16" exhaust tube in a later step. For all 2022 and older model vehicles keep the fuel cap connected to the tube.

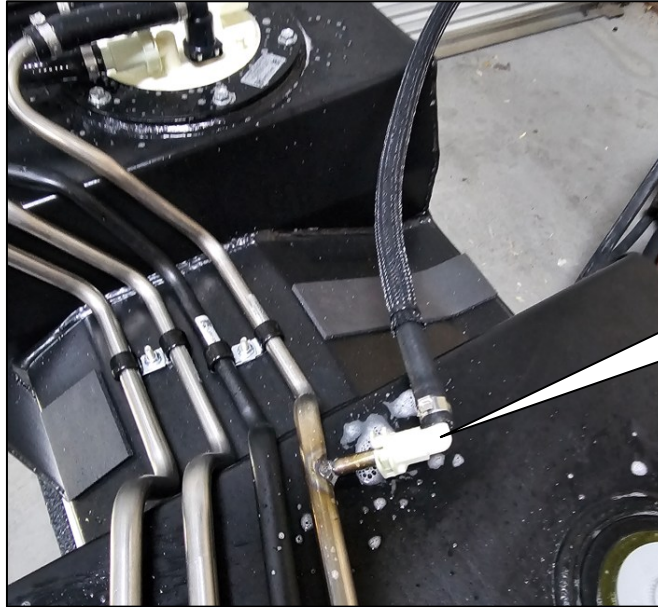

5/16" 90-degree  
hose connection to  
return fuel line.

36. The fuel / water separator filter orientation is changed to allow room for the TFI 58-gallon fuel tank. As a result, the electrical connection that goes to the bottom of the fuel filter will need to reach a little farther forward than it did in the OEM configuration. To facilitate this, a push in connector that secures the wiring for the electrical needs to be removed from the inside of the frame.

37. Add 10" long sleeving to vehicle hose line. Slide sleeving over fitting and use 2 zip ties to secure the sleeving.



Add 10"  
long sleeving  
to this hose

Remove push in  
connector to allow  
electrical to reach  
water separator  
filter on TFI tank.

38. Release the DEF supply line by removing the two clips located on the driver's side frame rail, between the Rear/Driver's Side Fuel Tank Strap and the DEF Tank. This line will need to be moved to provide clearance around the replacement fuel tank.

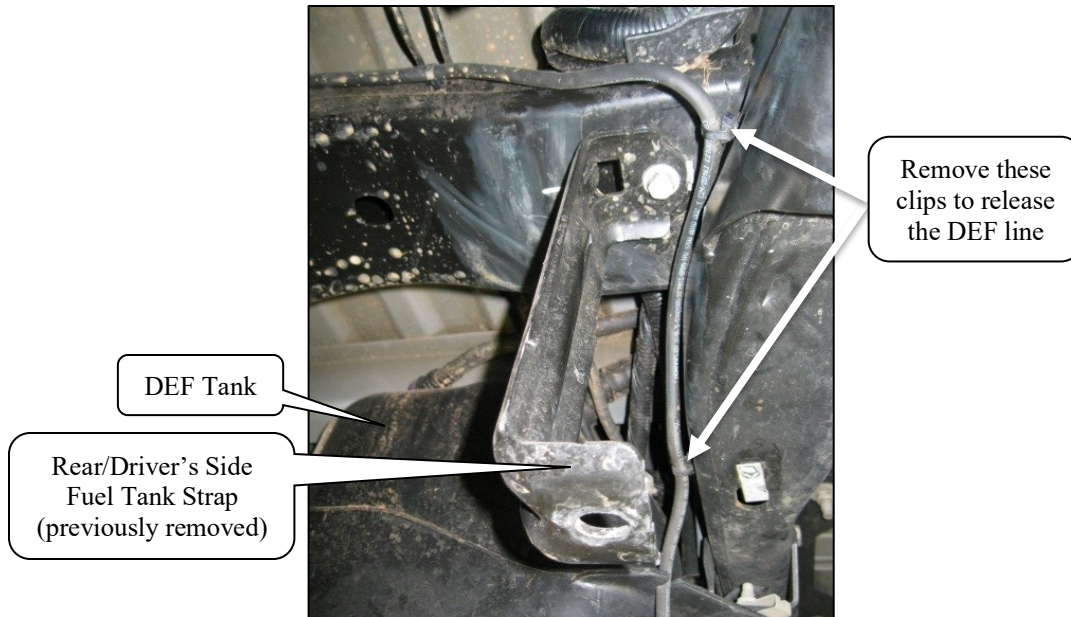

39. In order to achieve the 58-gallon capacity of the TFI midship replacement fuel system, a vapor space balance hose needs to be installed. There are two ¼" NPT pipe plugs on the side of the TFI fuel tank that need to be removed to allow two brass barb 90° fittings to be installed.

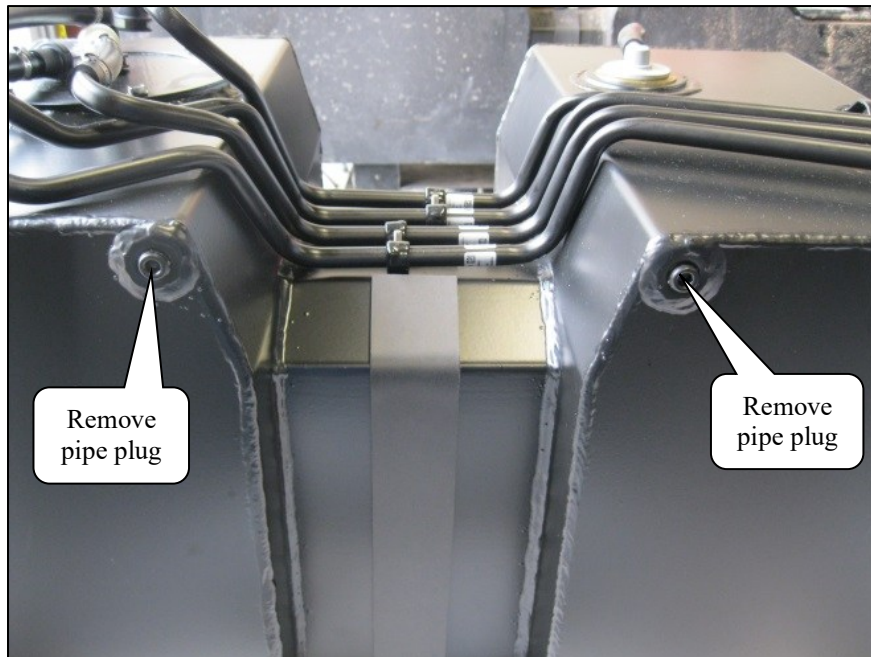

40. Once the plugs are removed, apply fuel rated thread sealant to the threads of the two provided 1/4" NPT brass barb 90° fittings and install the fittings at approximately a 45° angle as shown.

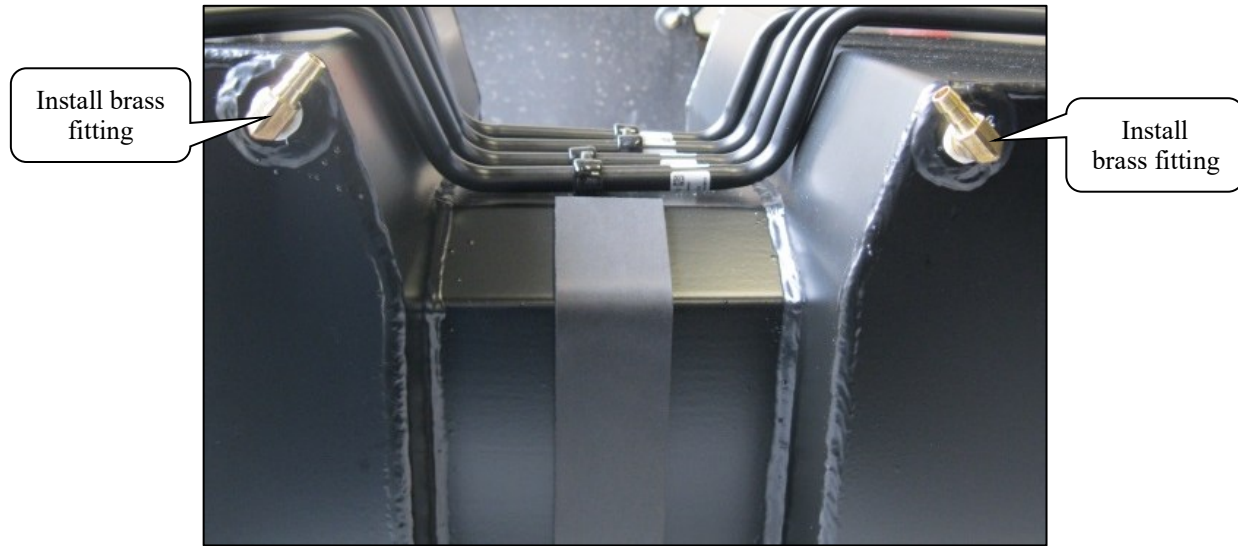

41. Use hose lubricant to install the provided 5/16" hose with plastic sleeving onto the barb ends of the brass barb fittings and secure with the provided clamps as shown. Refer to Instruction Sheet #484 for proper torque specifications.



42. The tank must now be pressure tested. Seal off the supply and return tubes on the sending unit and the rollover vent valves. Pierce a small hole in the red plastic cap on the fill neck and pressurize the tank to a **MAXIMUM** of 5 psi. Using a soapy water solution, thoroughly check for leaks around all openings. If any are present, reseal the affected area and retest.
43. Once a successful pressure test has been completed, remove the caps from the fill and vent hose ports on the TFI tank.
44. Disconnect the end of the 5/16" vapor space hose that has a tie wrap securing the plastic sleeving to the hose as it needs to be routed over a crossmember on the vehicle frame during installation.
45. Remove the OEM fill and vent hose from the OEM tank taking note of the orientation of the hoses.
46. ***For Super cab vehicles ONLY***, it will be necessary to cut the fill and vent hoses before installing them on the TFI fuel tank following steps 46 through 50. If the hoses are not cut, the fill and vent hose will kink not allowing proper filling when installed back onto the filler neck in the OEM configuration.

47. Remove the expanded plastic sleeving from the fill and vent hose if necessary to cut the hose and maintain sufficient room to install the hose clamp back onto the hose during installation.
48. Remove approximately 1.5" from the fill pipe end of the fill pipe vent hose as seen in the following images.



49. Remove approximately 1.0" from the fill pipe end of the fill hose as seen in the following images.



50. Install the expanded plastic sleeving back onto the fill and vent hose and use the provided tie wraps to secure the sleeving onto the hoses. Be sure there is adequate room to properly install the hose clamps on the ends of the hose without interference from the plastic sleeving, cut the plastic sleeving if necessary to allow room for installation of the hose clamps.
51. Using the OEM hose clamps, install the fill and vent hoses on the TFI fuel tank in a similar orientation to how they were installed on the OEM fuel tank. For Crew cab short box vehicles, the fill and vent hoses are routed toward the back of the vehicle and the vent hose crosses over the top of the fill hose as seen in the following image. For Super cab long box vehicles, the fill and vent hoses are routed toward the front of the vehicle as seen in the following image. Refer to Instruction Sheet #484 for proper torque specifications.

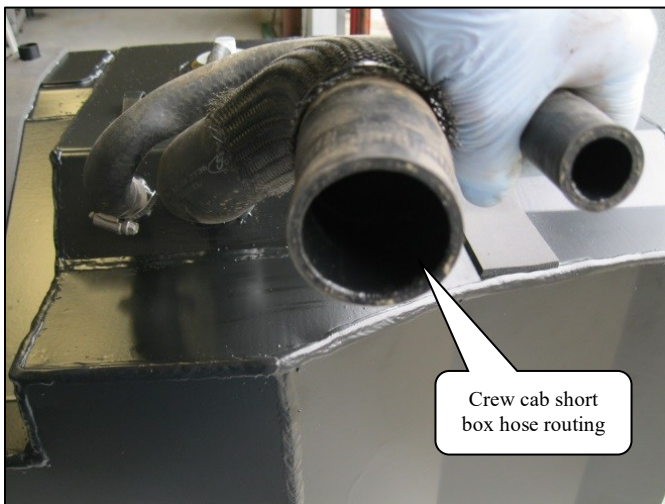

## SECTION 4: TFI TANK INSTALLATION:

52. Position the TFI fuel tank underneath the vehicle in the midship mounting location. The fill and vent tubes must be facing toward the driver's side frame rail.
53. Slowly raise the fuel tank until the supply and return connections can be made between the front of the TFI tank and the OEM lines along the driver's side frame rail. Reach over the top of the front of the TFI tank to make the connections. Like the connections on the pump sending unit and fuel / water separator filter, the ½" and 12mm fuel connections can only be installed one way. Verify that the fuel lines are not pinched or kinked when the replacement tank is fully installed.

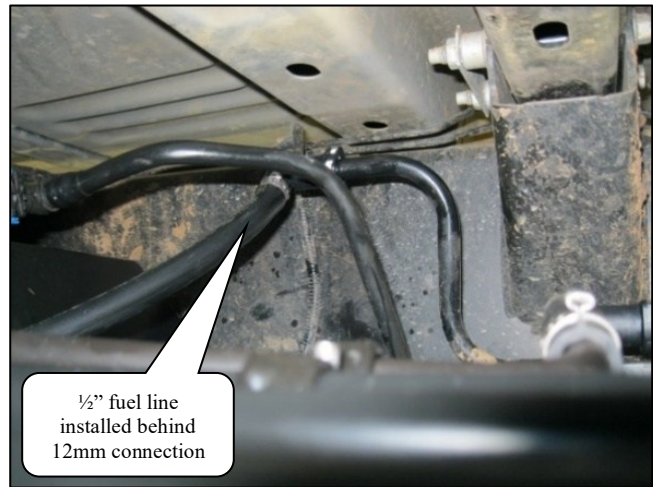
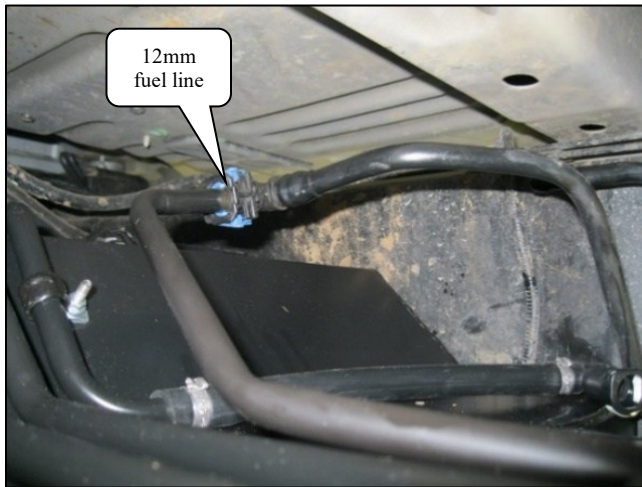

54. **2023 – Present Vehicle Models ONLY:** At this time route the exhaust fuel line over the crossmember to avoid being pinched or kinked during installation.



55. It will be necessary to raise the ½” fuel line next to the driver’s side frame rail to connect it to the OEM fuel line. Be sure the ½” line is under the 12mm line when making the connections. Once the tank is raised into final position the lines will be in the correct positions.



56. After each fuel line connection is made, slide the lock closed to secure the connector to the line. Gently pull on the connector to be sure it does not come off of the fuel line during operation.

57. ***2023 – Present Vehicle Models ONLY:*** Connect the 5/16” hose straight fitting to the 5/16” exhaust tube. Route the hose over the middle crossmember to complete the connection. Check the connection by pulling on the fitting to verify that the clip is locked in place.



58. After making the fuel line connections, as the tank is raised further, route the 5/16” vapor space hose over the cross member.

59. ***For Crew cab short box vehicles only***, it may be necessary to cut 2” off the 5/16 hose to prevent any kink in the hose after installation. Also on Crew cab short box vehicles, there is a wire convolute on the front top edge of the cross member that will need to be pushed out of the way to allow the hose to go completely over the cross member as seen in the following image.



60. With the hose routed around the convolute the hose can be pulled from the other side of the cross member as the tank is raised into position. The hose can then be connected to the brass barb fitting and secured with the provided clamp. Refer to Instruction Sheet #484 for proper torque specifications.
61. Do not to pinch the fuel lines, vent lines, fuel fill hose, or electrical convolute as the tank is raised into position.
62. There is a locating pin on the top of the TFI fuel tank that goes into a hole in the middle cross member that locates the TFI fuel tank into the vehicle. As the tank is raised into its final position, align the locating pin in the hole in the cross member. If it becomes difficult to install the tank straps in the following steps, verify that this locating pin is in the hole in the cross member and the tank foam is contacting the frame.

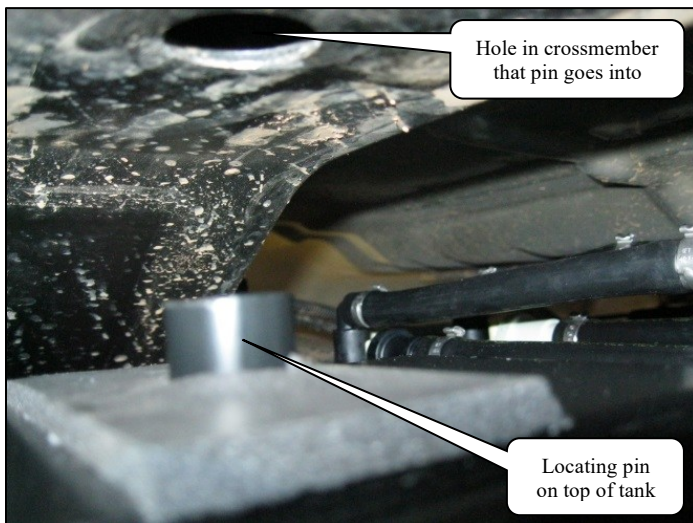

## NOTE: OEM ROCK SHIELD AND EXTRA HARDWARE

- If the vehicle is equipped with an OEM fuel tank rock shield, the provided hardware will not be required. The OEM hardware can be reused.
- If the vehicle is **NOT** equipped with an OEM fuel tank rock shield, use the provided M8x1.25 clip nuts as shown below.

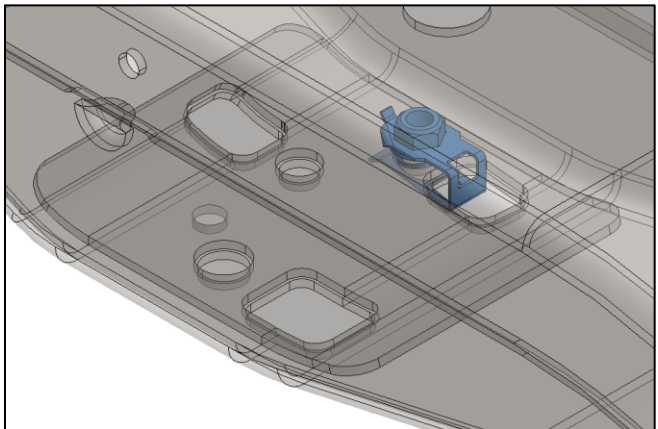
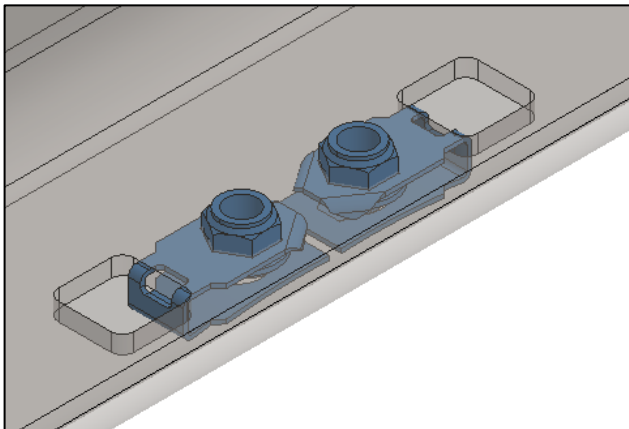
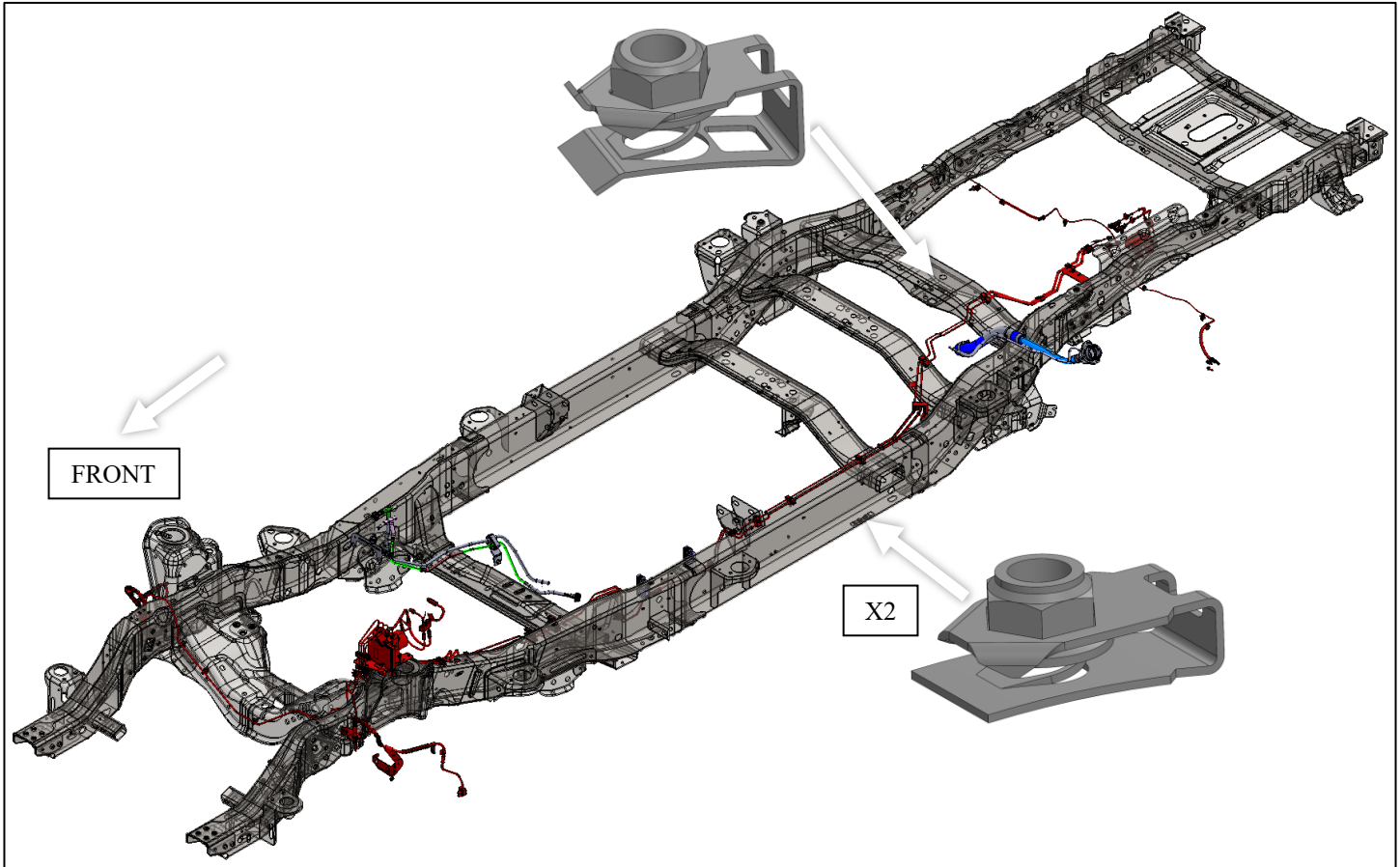

63. The rear strap bracket uses an M12 bolt near the rear spring hanger for the rear leaf spring on the driver's side frame rail. Using a 15mm socket remove the M12 bolt. Loosely install the TFI rear strap bracket. The bracket will be fully tightened after the connection is made to the rear tank strap.

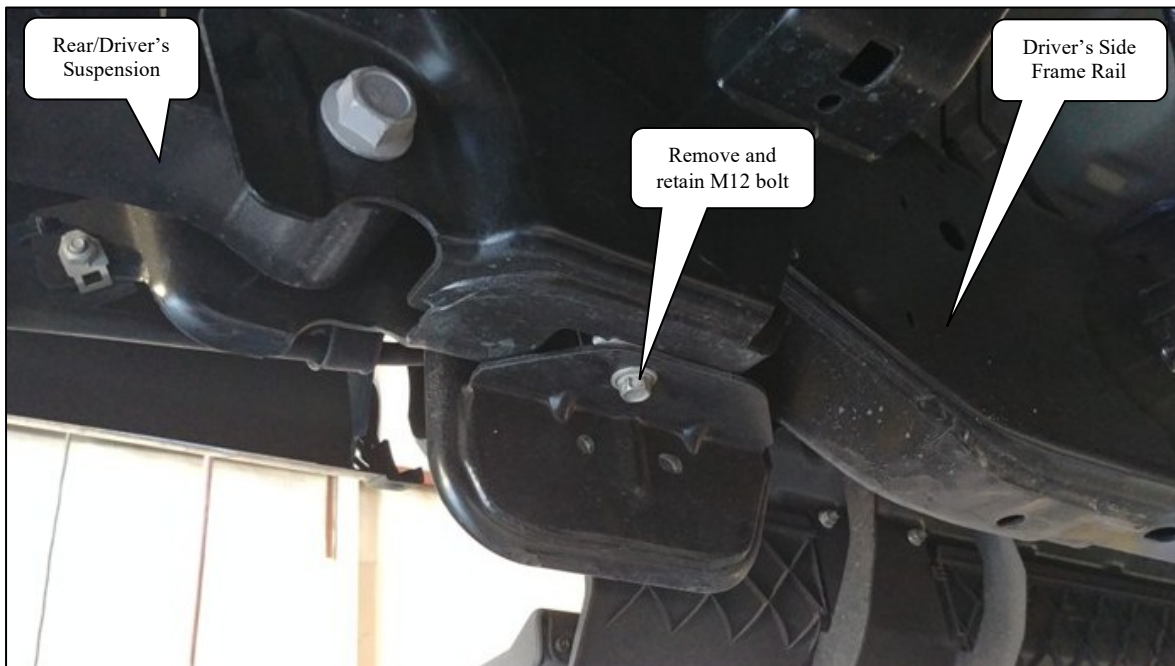

64. Install the four provided fuel tank straps to secure the fuel tank to the vehicles frame.

- Install Front/Driver's Side Strap Bracket (040-01-16577). Use the OEM M8 hardware (from the rock shield) to fasten the strap to the frame rail. If no OEM rock shield was previously installed, use the provided M8 clip nuts and M8X20 bolts to secure the strap bracket to the frame rail.
- Install Front/Passenger Side Tank Strap (040-01-16570). Loosely install the two provided M10 nuts and bolts to connect the Front/Drivers's Side Strap Bracket (040-01-16577) to the Front/Passenger Side Tank Strap (040-01-16570). Do not fully tighten the bolt to allow for adjustment.

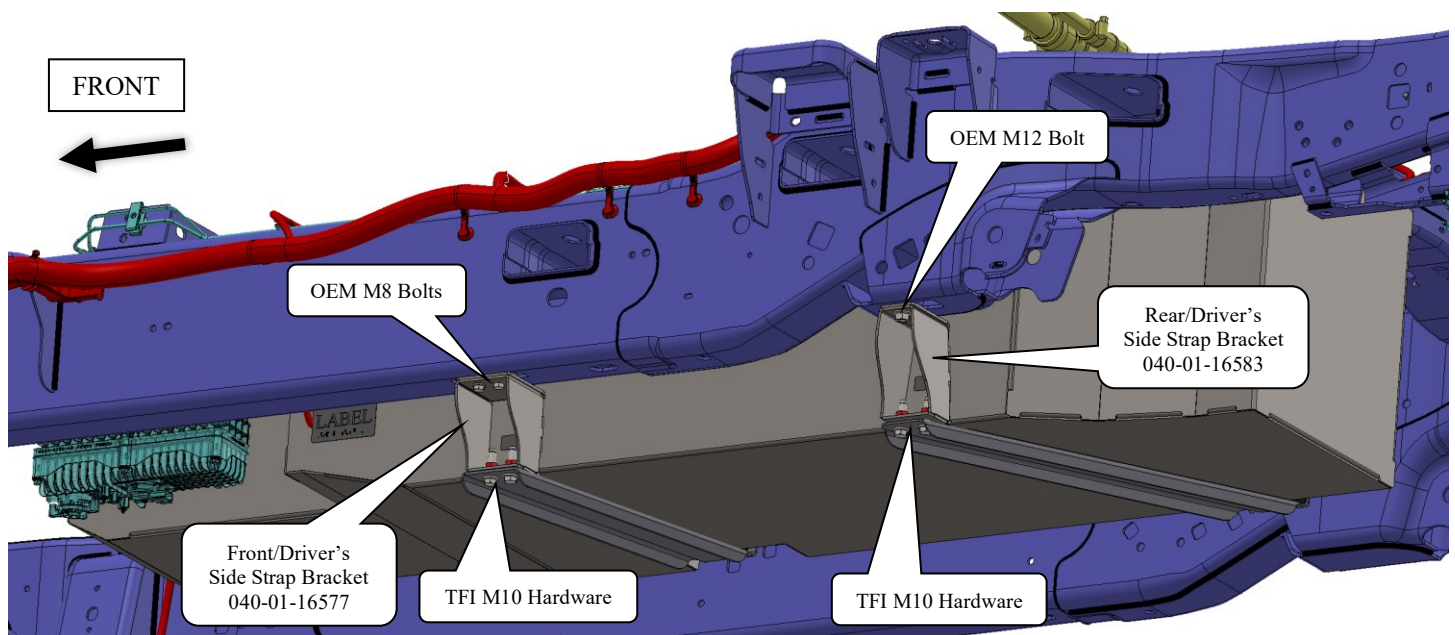

- c. Install the provided M12 bolt and nut to secure the Front/Passenger Side Tank Strap (040-01-16570) to the frame crossmember. Do not fully tighten the bolt to allow for adjustment.

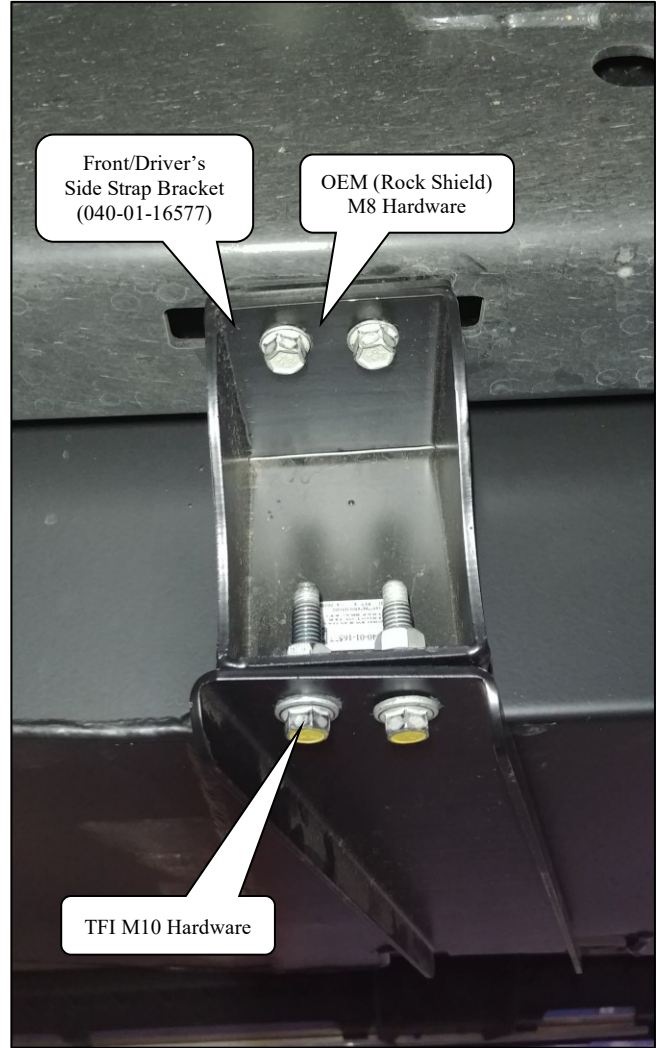

- d. Install Rear/Driver's Side Strap Bracket (040-01-16583). Use the OEM M12 bolt from Step 63 to fasten the strap bracket to the frame rail. Do not fully tighten the bolt to allow for adjustment.
- e. Install Rear/Passenger Side Tank Strap (040-01-16571). Loosely install the two provided M10 nuts and bolts to connect the Rear/Drivers's Side Strap Bracket (040-01-16583) to the Rear/Passenger Side Tank Strap (040-01-16571). Do not fully tighten the hardware to allow for adjustment. Use the OEM M8 (from rock shield) and M12 (long) bolts to secure the strap to the crossmember. If no OEM rock shield was previously installed, then install the provided M8 clip nut and bolt to secure the tank strap to the frame rail. Do not fully tighten the bolt to allow for adjustment.

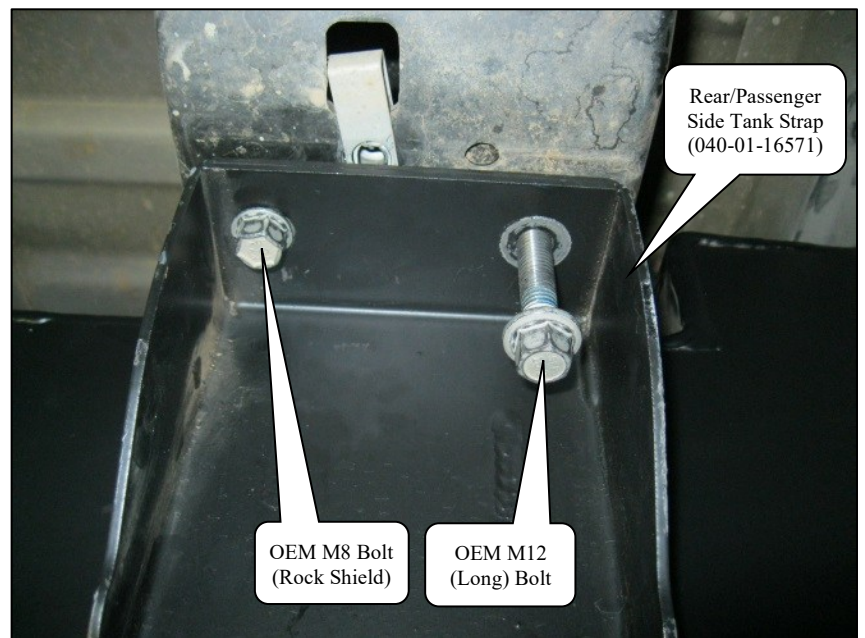
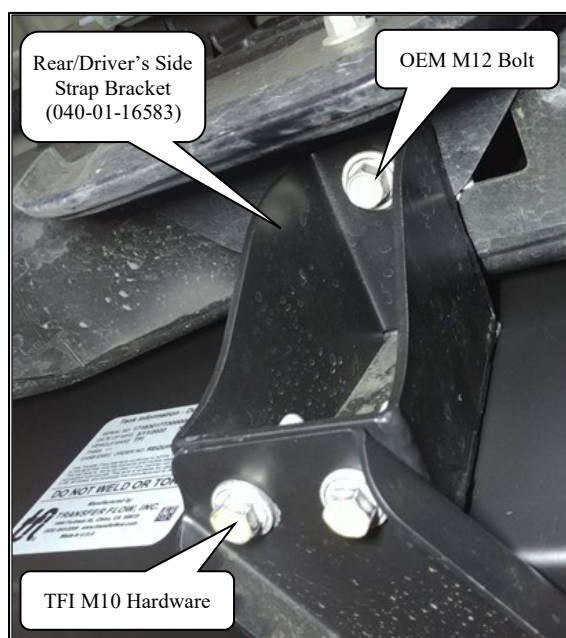
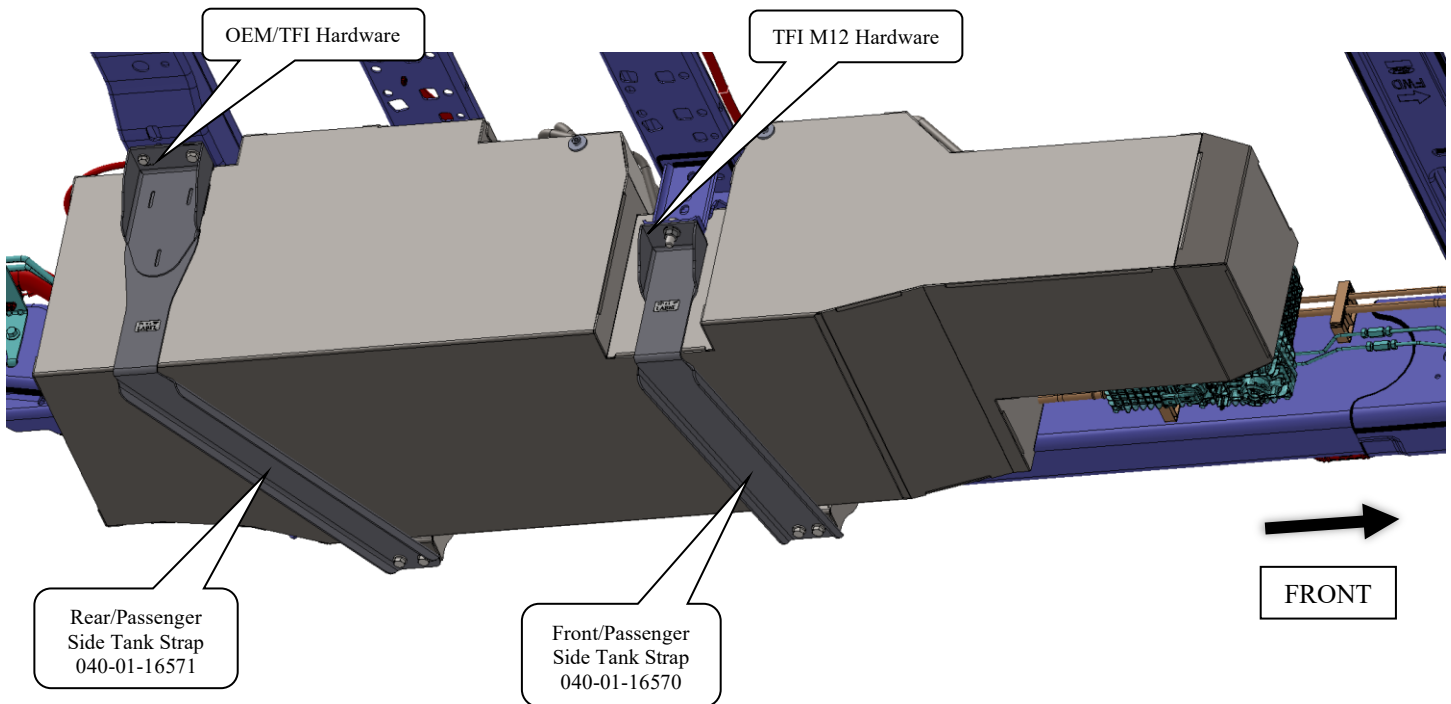

65. Confirm that the tank straps are hanging straight down and there is at least 1-<sup>1</sup>/<sub>2</sub>" of clearance between the tank, differential and any part of the drive shaft. Tighten all strap bolts and strap bracket bolts, refer to Instruction Sheet #484 for proper torque specifications.
66. Reconnect the filler neck hose and vent hose to the OEM fill and vent tubes in the OEM fill pipe. Verify that the fill and vent lines are not kinked or contacting any component to ensure proper filling. Adjust the orientation of the fill and vent lines on the fill pipe as necessary before securing the OEM clamps. Refer to Instruction Sheet #484 for proper torque specifications.
67. Connect the electrical connector from the main harness to the OEM sending unit. Push the fittings together until an audible click is heard. Gently pull on the connector to be sure it will not come off during operation.
68. Connect the electrical connection to the fuel / water separator filter. Push the fittings together until an audible click is heard. Gently pull on the connector to be sure it will not come off during operation.



**If the electrical connection for the fuel / water separator is left off, the vehicle will display the warning for water in fuel. If this condition is not corrected the vehicle will go into a reduced power mode until this condition is corrected. If you receive the message that there is water in the fuel following the installation of the TFI 58-gallon midship replacement fuel system, immediately shut off the engine and verify the installation of the electrical connection on the sensor in the fuel / water separator filter. If the connection is correct, follow the owner's manual procedure for draining the filter.**

## **SECTION 5: FINALIZE THE INSTALLATION:**

69. Make sure all fuel, fill, and vent lines, along with all electrical wires are not kinked or pinched, close to any heat source, or in contact with any sharp edges. Confirm that the vent line has a continuous downward slope from the filler neck to the fuel tank. Verify that all bolts, clamps, lines, and electrical connectors are secure.
70. Reconnect the battery cables.
71. Fill the replacement tank with fuel.
72. Use the accessory position to run the in-tank fuel pump to purge air out of the fuel lines and fuel filter. Complete the purge cycle 5 times to clear air from fuel system.
73. Start the engine and check for normal engine and fuel gauge operation. If any problem is detected, shut off the engine and repair the connection.

**Congratulations on a successful installation!**