

REFRIGERATOR MANUFACTURER
Turbo air
 more durable, efficient, beautiful

4184 E. Conant St.
 Long Beach, CA 90808
 Tel. 310-900-1000
 Fax. 310-900-1077
www.turboairinc.com

Project :

Model # :

Item # :

Qty :

Available W/H :

Approval :

Diamond Show Case

Display Cases
 Refrigerated Show Cases

Model : CRT-77-2R



Pass Through

≡ FEATURES & BENEFITS ≡

■ **LED lighting interior display system**

Safety shielded 4 LED lighting system on every corner of the cabinet ensures a longer life and brighter lighting than fluorescent light bulbs, providing attractive, enhanced and shadow-free illumination.

■ **Efficient refrigeration system**

Turbo Air's refrigerators are designed with oversized and balanced R-134A (CFC Free) refrigeration. These include efficient evaporators and condensers for faster cooling and greater efficiency.

■ **Beautiful 4 sided glass cabinet allows visibility from all sides to optimize display effect**

■ **Compact size and countertop design occupies minimum space but maximize impulse sales**

■ **Great space efficiency is ideal for narrow space restaurants and convenience stores**

■ **Elegant contemporary Euro design will enhance the interior and space decoration of any store**

■ **Sturdy, clean stainless steel shelving**

Shelves are the most important part of cleanliness as they come in direct contact with food. After a while, PVC coated wire shelves may peel, rust and lead to unsanitary conditions. Only the Turbo Air Diamond Show Case uniquely provides stainless steel shelving.

■ **Recommended operating conditions**

CRT models are designed to operate in environments where temperature & humidity do not exceed 75°F and 55% relative humidity.



| Model | Swing Door | CU./FT. | # of Shelves | HP | AMPS | Crated Weight (lbs.) | L x D x H (inches) |
|------------------|------------|------------|--------------|------------|------------|----------------------|------------------------------|
| CRT-77-2R | 2 | 3.0 | 3 | 2/9 | 2.6 | 90 | 163/4 x 167/8 x 381/2 |

Model : CRT-77-2R

| ELECTRICAL DATA | |
|-------------------------|---|
| Voltage | 115/60/1 |
| Plug Type | Ⓜ NEMA 5-15P |
| Full Load Amperes | 2.6 |
| Compressor HP | 2/9 |
| Refrigerant | R-134A |
| Cord Length (ft.) | 6.5 |
| DIMENSIONAL DATA | |
| Net Capacity cu. ft. | 3 |
| Ext. Length Overall in. | 16 ³ / ₄ (425mm) |
| Ext. Depth Overall in. | 16 ⁷ / ₈ (427mm) |
| Ext. Height Overall in. | 38 ¹ / ₂ (978mm) |
| Int. Length Overall in. | 14 ³ / ₈ (366mm) |
| Int. Depth Overall in. | 13 ¹ / ₈ (335mm) |
| Int. Height Overall in. | 25 (635mm) |
| Net Weight lbs. | 82.5 |
| Gross Weight lbs. | 90 |
| # of Shelves | 3 |
| Self Size | 14 ³ / ₈ x 12 ³ / ₄ |

Design and specifications subject to change without notice.
Actual shipping weight may differ due to extra packing materials for product protection.

- **WARRANTY : 1 Year Parts and Labor Warranty
Additional 4 Year Warranty on Compressor**
- **Self-contained system**

PLAN VIEW

(unit : inch)

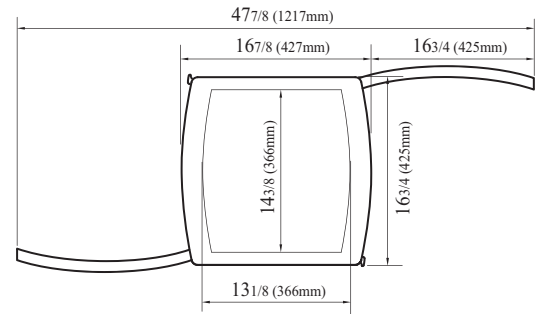

PLAN VIEW

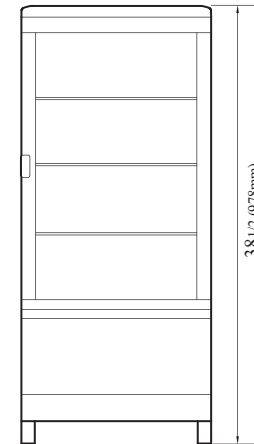

FRONT VIEW

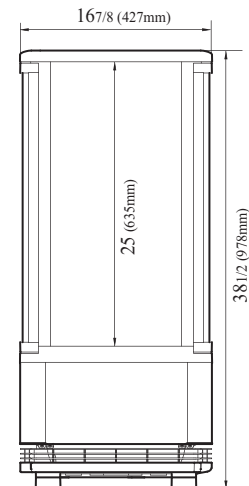

SIDE VIEW

Ver.201501



- Turbo Air : 800-627-0032
- GK : 800-500-3519
- Warranty : 800-381-7770
- AC : 888-900-1002