



JOB \_\_\_\_\_ ITEM # \_\_\_\_\_

# HEAVY POT RANGES

Base Models: FK430, FK43, 2FK430



**Model FK430**  
(shown with extra rack & optional casters)



## Standard Features, Benefits & Options

**OVENS:** 31.5" w x 22" d x 14" h for superior baking characteristics and results around common 26" x 18" sheet pans. Heavy insulation for fuel efficiency. Easy cleaning porcelain and aluminized linings with one nickel plated rack. 3 rack positions with 2 $\frac{3}{4}$ " between rack positions. Long life, 30,000 BTU cast iron "H" pattern oven burner combined with special "V" shaped baffle directs heat for excellent air circulation.

**COOK TOPS:** 25,000 BTU "star" pattern top burners offer a more efficient burn pattern for small to large pots. Optional 40,000 BTU burners available. Full width crumb trays catch all spillage. Four cast iron top grates measuring approximately 18" x 14" are designed to accommodate and more easily move large diameter pots across top sections.

**CONSTRUCTION:** Easy cleaning, corrosion resistant stainless steel finish, welded with angle iron and aluminized inner framing. Sturdy 6" heavy duty stainless pipe legs with adjustable feet. Double wall construction with heavy insulation for cooler operation. Installation clearances for non-combustible surfaces are 0" on sides and 0" in the rear, combustible surface clearances are 6" and 6".

**CONTROLS:** Includes 500° thermostat, 100% safety shut off, automatic standing pilot and brass top burner valves. Pressure regulators are set at the factory for the gas specified. Optimal pressures are 4" WC for natural gas and 10" WC for propane. Manifold size is  $\frac{3}{4}$ " NPT. All controls are tested and confirmed in good working order. Calibration and adjustments are the responsibility of the buyer.

**GRIDDLE PLATES:** Available either 18" or 36". 18" griddles feature 2, "I" burners rated at 18,000 BTU each. 36" griddles feature 3, "H" burners rated at 20,000 BTU each.  $\frac{3}{4}$ " thick is standard. Stainless steel splash guards tapering to 4". Front grease trough and large capacity grease catch. Optional raised griddle-cheesemelters with rear trough are available. Maximum rack clearance is 4 $\frac{1}{2}$ ".

**CHAR-BROILERS:** Available either 18" or 36". 18" char-broilers feature 2, "I" burners rated at 20,000 BTU each. 36" char-broilers feature 3, "H" burners rated at 25,000 BTU each. Flare up reducing cast iron top grates and radiants for superior heat retention. Front grease trough and large capacity grease catch. SS splash guards tapering to 4". Char-broilers are approved for use in non-combustible locations only.

**HOT TOPS:** Available either 18" or 36". 18" hot tops feature 2, "I" burners rated at 18,000 BTU each. 36" hot tops feature 3, "H" burners rated at 20,000 BTU each.  $\frac{3}{4}$ " thick is standard.

**ACCESSORIES & OPTIONS:** Convection fan, casters, extra racks, pizza decks, FD oven thermostats, oven spark pilots, chrome griddle plates, 1" thick griddle plates, griddle thermostats, safety pilot griddles, lift off griddles, grill scrapers, cleaning supplies, hose and quick disconnects, control protection bars, storage base in lieu of oven and low backs are some of the standard options and accessories available.



Comstock-Castle Stove Co. • 119 W. Washington St. • Quincy, IL. 62301  
Tel.: 217-223-5070 • Fax: 217-223-0007 • [www.castlestove.com](http://www.castlestove.com)



## HEAVY POT RANGES MEASUREMENTS

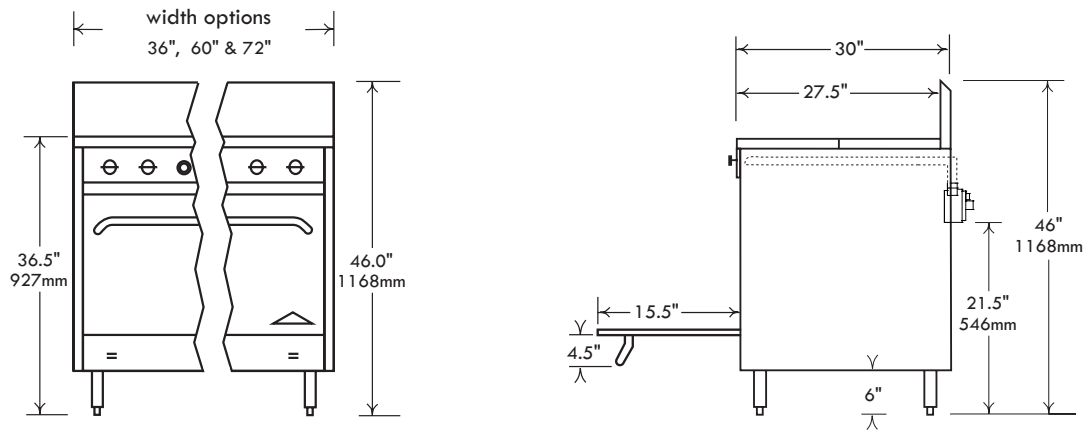

### Heavy Pot Ranges (Popular models shown below. Call factory for other model details.)

Cooktop Configuration	Width	Model #	Description		Total B.T.U.	Approx. Wgt. Kg. / Lbs.
			Top	Base		
	36"	FK430	(4) Open Burners	- w/ (1) 31.5" Oven	130,000 / 190,000	227 / 500
		FK43	(4) Open Burners	- w/ (1) cabinet base	100,000 / 160,000	195 / 430
	36"	FK430-18	(2) Open Burners & 18" Griddle	- w/ (1) 31.5" Oven	116,000 / 146,000	239 / 525
		FK43-18	(2) Open Burners & 18" Griddle	- w/ (1) cabinet base	86,000 / 116,000	207 / 455
	36"	FK430-1.5RB	(2) Open Burners & 18" Radiant Broiler	- w/ (1) 31.5" Oven	120,000 / 150,000	239 / 525
		FK43-1.5RB	(2) Open Burners & 18" Radiant Broiler	- w/ (1) cabinet base	90,000 / 120,000	207 / 455
	60"	FK3226-24	(4) Open Burners & 24" Griddle	- w/(2) 26.5" Ovens	200,000 / 260,000	409 / 900
	72"	2FK430	(8) Open Burners	- w/(2) 31.5" Ovens	260,000 / 380,000	455 / 1000
	72"	2FK430-18-1.5RB	(4) Open Burners, 18" Griddle, & 18" Radiant Broiler	- w/(2) 31.5" Ovens	236,000 / 296,000	482 / 1060
	72"	2FK430-24-1RB	(4) Open Burners, 24" Griddle, & 12" Radiant Broiler	- w/(2) 31.5" Ovens	225,000 / 285,000	536 / 1180

