

A

B

C

D

E

CHANGE	
00	MLHI 9-8-15 ECN 15-028
$\triangle A1$	(C-2) .10 X 45° CHAM WAS .03 X 45° CHAM
01	JVKI 9-7-16 ECN 16-009
$\triangle B1$	(E-1) PLATE TYPE V WAS TYPE II
$\triangle B2$	(E-1) CD STL WAS FREE MCHNG
02	FDKI 3-20-18 ECN 18-013

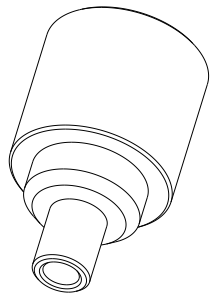

SCALE 1:2

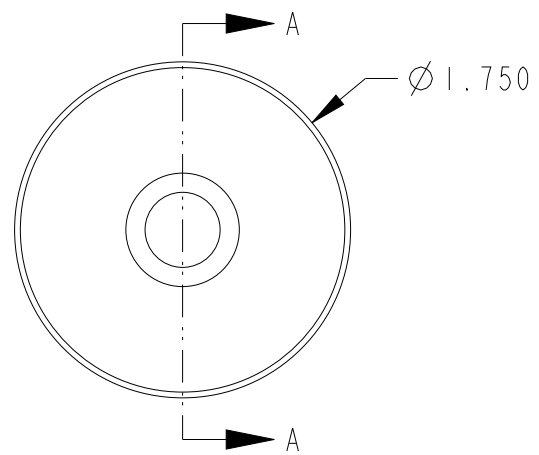
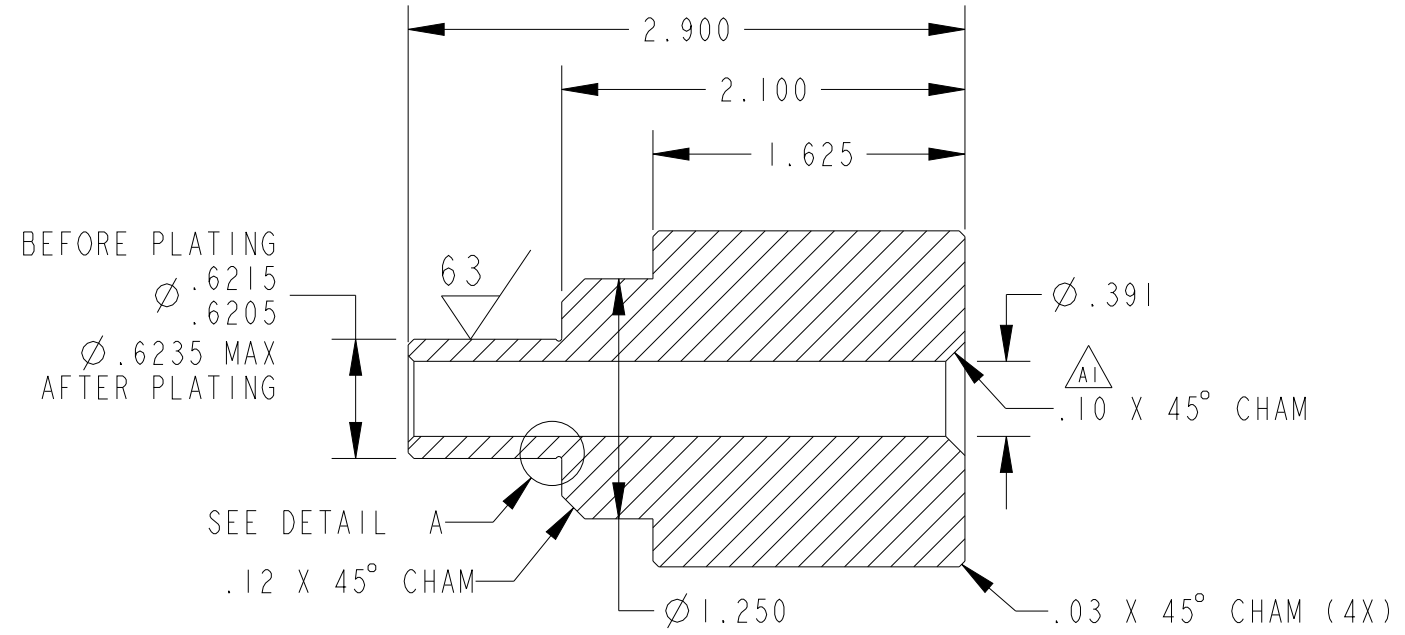

SECTION A-A

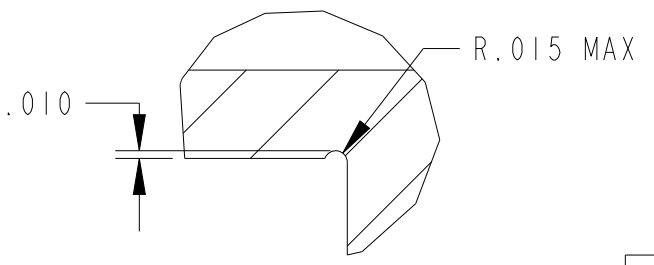

DETAIL A SCALE 4:1

SUGGESTED SOURCE	VENDOR P/N
PMI	-
BULLSEYE	-

PRO-E		CONFIDENTIAL PROPERTY OF SCAG POWER EQUIPMENT	
DIVISION OF METALCRAFT OF MAYVILLE, INC P.O. BOX 152 MAYVILLE, WI 53050		TITLE PIVOT, IDLER ARM	
DIM TOL UNLESS SPECIFIED X.X = ± 0.040 X.XX = ± 0.020 X.XXX = ± 0.010 ANGLES = ± 0° 30' HOLES PER SCAG 08002 FORMED VIEW DIM'S TO BE USED FOR INSPECTION		MATERIAL - MILL TOLERANCES APPLY UNLESS NOTED 1.75 DIA CD STL RD (NO LEAD) $\triangle B2$ MATERIAL - ADDITIONAL DESCRIPTION	
DRAWN MJMI 6-22-15 CHECKED MLHI 9-8-15 APPROVED - -		FINISH ZINC PLATE SCI, TYPE V (CLEAR) PER SCAG 08001 $\triangle B1$ THIRD ANGLE PROJECTION SURFACE FINISH \checkmark SIMILAR TO 43632 SCALE 1:1	
		ALT FINISH W/ ENGR NOTIFICATION SIZE PART NO B 431025	

A

B

C

D

E

STC11