

PRODUCT SPECIFICATION

# FSE Undercounter Refrigerators & Freezers

## features

Models: MRUCRF-48, MRUCFZ-27, MRUCFZ-48



MRUCRF-27



MRUCFZ-48

### FOOD SERVICE ESSENTIALS

For Food Service Professionals

#### STANDARD FEATURES

- Easy to clean, 430 series stainless steel exterior
- Interior constructed of 304 stainless steel
- Digital temperature control ranges 33°F to 41°F in refrigerators and -8°F to 0°F in freezers
- Epoxy coated, corrosion resistant shelves with 90 lb. capacity per shelf
- Self-closing door, with micro-switch that shuts the evaporator fans off when door is open
- Preprogrammed digital control featuring auto-defrost cycle
- Foamed-in-place insulation helps provide strength, while helping to maintain internal temperature
- Eco-friendly R290 hydrocarbon refrigerant
- All models come with 4" casters

Keep foods cold and easily accessible with these compact undercounter refrigerators from FSE. Constructed of heavy-duty, stainless steel, these units fit under your countertop making them the perfect solution to adding more space anywhere you need. The flat stainless steel countertop allows for them to be used as a separate workstation. All undercounter units come with 4" casters and plastic coated wire shelving. Models are ETL Listed and ETL Sanitation, and are backed with a 2 year warranty on parts and a 5 year warranty on the compressor.



#### COOLING SYSTEM

- R290 hydrocarbon refrigerant is an environmentally-responsible choice for your business.
- Maintains a temperature range of 33°F to 41°F (refrigerators) and -8°F to 0°F (freezers)
- Rugged built axial evaporator fans run efficiently with low velocity and high volume air flow



#### CABINET CONSTRUCTION

- Exterior is constructed of 430 corrosion-resistant stainless steel, including doors
- Interior is constructed of 304 corrosion-resistant stainless steel
- Insulated cabinet with foamed-in-place, high density cell polyurethane insulation

#### ELECTRICAL CONTROL

- LED temperature display provides easy temperature adjustment when necessary
- Carel temperature controller initiates automatic defrost cycle for worry-free use
- 7-foot power cord with NEMA 5-15 plug

#### DOOR(S)

- Stainless steel exterior
- Positive self-closing doors with micro-switch that shuts the evaporator fans off when the door is open
- Recessed handles are built into the door for easy opening and closing
- Removable door gasket for easy cleaning

#### SHELVING

- Adjustable plastic coated steel shelves have a load capacity of 90 lbs. per shelf
- Shelving installed with K-clips

#### MODEL FEATURES

- 4" casters come standard on all stainless steel models, 2 locking wheels and 2 non-locking wheels
- Stainless steel top is 2" thick



**Attention CA Residents**  
**PROP 65 WARNING**  
 This product can expose you to chemicals, including lead, which are known to the State of California to cause cancer, birth defects, or other reproductive harm.  
 For more information, go to [www.P65warnings.ca.gov](http://www.P65warnings.ca.gov)

**MADE IN CHINA**

*RESIDENTIAL: FSE assumes no liability for parts or labor coverage for component failure, factory defect or any other damages for units installed in non-commercial foodservice or residential applications.*



PRODUCT SPECIFICATION

# FSE Undercounter Refrigerators & Freezers

## features

Models: MRUCRF-48, MRUCFZ-27, MRUCFZ-48

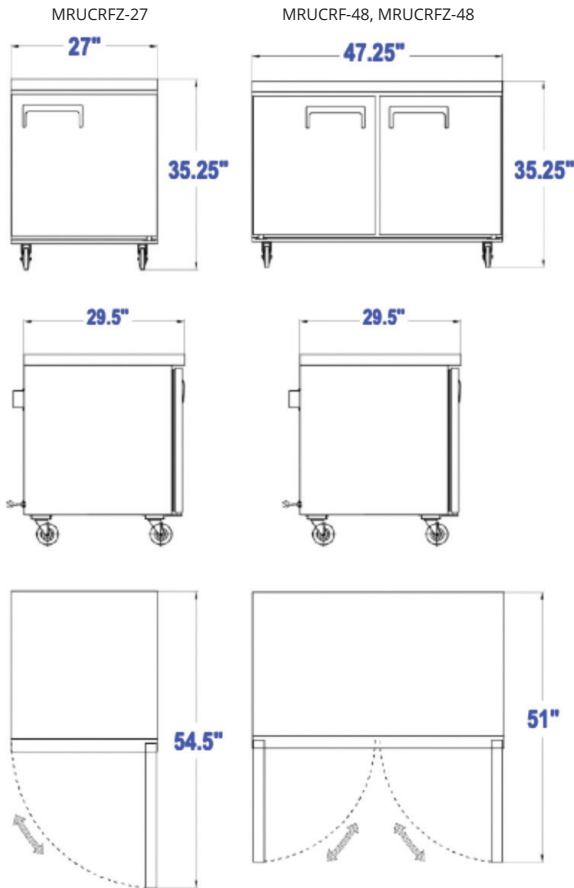

## PRODUCT DETAILS

### UNDERCOUNTER REFRIGERATORS

Model Number	MRUCRF-48
Doors	2
Shelves	2
Net Volume (Cu. Ft.)	12
Overall Dimensions (in)	47.25\"W x 29.5\"D x 35.25\"H
Interior Dimensions (in)	42.5\"W x 23\"D x 23.5\"H
Horsepower	1/5
Refrigerant	R290
Voltage/Hertz/Phase	115/60/1
Amps	2.7
Net Weight (lbs)	238
Gross Weight (lbs)	299
Shipping Dimensions (in)	50\"W x 32.5\"D x 38.5\"H

### UNDERCOUNTER FREEZERS

Model Number	MRUCFZ-27	MRUCFZ-48
Doors	1	2
Shelves	1	2
Net Volume (Cu. Ft.)	6.3	12
Overall Dimensions (in)	27\"W x 29.5\"D x 35.25\"H	47.25\"W x 29.5\"D x 35.25\"H
Interior Dimensions (in)	22\"W x 23\"D x 23.5\"H	42.5\"W x 23\"D x 23.5\"H
Horsepower	1/5	1/4
Refrigerant	R290	R290
Voltage/Hertz/Phase	115/60/1	115/60/1
Amps	2.1	3.12
Net Weight (lbs)	178	251
Gross Weight (lbs)	233	312
Shipping Dimensions (in)	29.7\"W x 32.5\"D x 38.5\"H	50\"W x 32.5\"D x 38.5\"H

