

4

3

2

1

REV	DESCRIPTION	DATE	APPROVED
-	INITIAL RELEASE		

DIMENSIONS ARE IN INCHES

ZMG No.	A	B			C			D(Ref)	E(Ref)	F(Ref)	G(Ref)	H		I
	SIZE	Width AF			HEIGHT			Width AC						
		MIN	NOMINAL	MAX	MIN	NOMINAL	MAX					MIN	MAX	
3456933	0.500-20	0.7990	0.8125	0.8130	0.6140	0.6250	0.6360	0.913	0.492	0.433	0.602	0.539	0.563	45±3°
3456934	0.562-18	0.9800	1.0000	1.0000	0.7078	0.7188	0.7330	1.114	0.570	0.492	0.708	0.657	0.678	45±3°
3456935	0.625-18	0.9230	0.9375	0.9450	0.8580	0.8750	0.8820	1.047	0.708	0.622	0.708	0.657	0.678	45±3°

Remark:

1. Require marking of two circumferential lines 60 degrees apart at two corner

60度角位置需打兩弧線

2. Indented ZMG markings

需打ZMG印

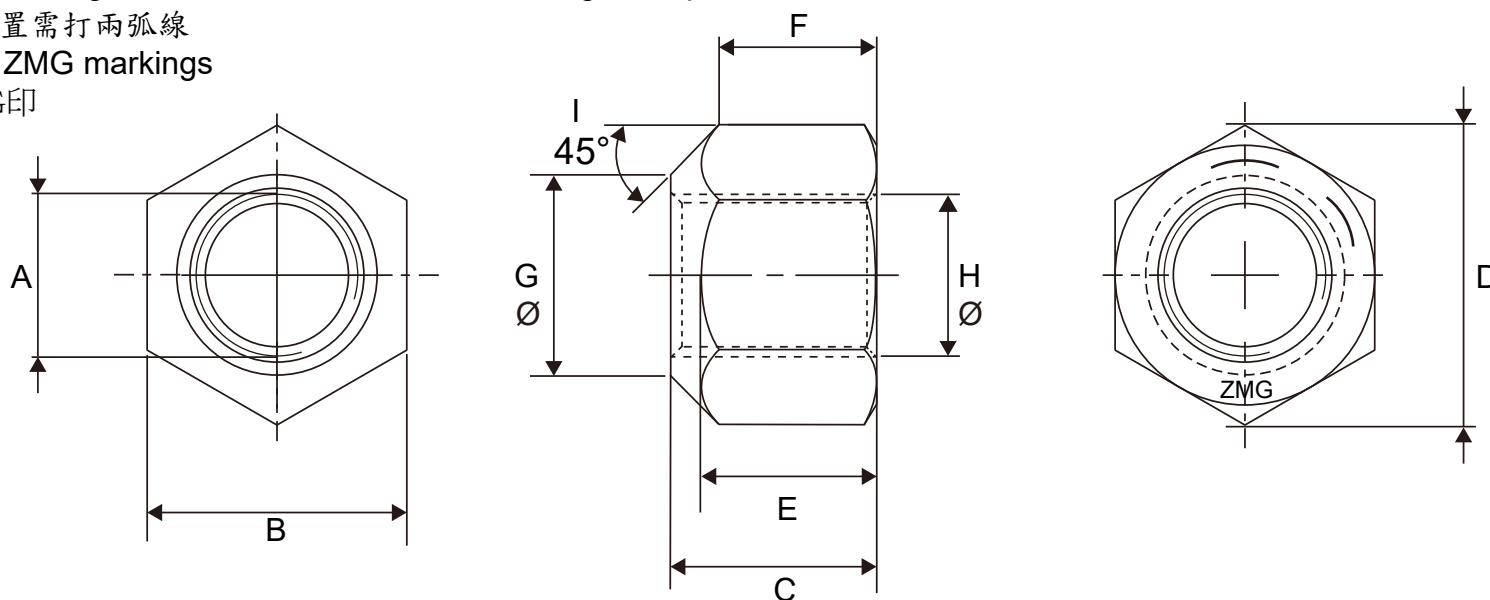

INTERPRET GEOMETRIC TOLERANCING  
DIMENSIONS ARE IN INCHES

DECIMAL TOLERANCES:  
LINEAR DIMENSIONS: ±  
ANGULAR DIMENSIONS: ±  
DRILLED HOLES: ±

DO NOT SCALE DRAWING

DRAWING No.	
APPROVALS	DATE
DRAWN BY JL	2025.5.20
CHECKED BY	
APPROVED BY	

**SHC** SHC HARDWARE LTD  
TEL:886-7-6261296 FAX:886-7-6264833  
www.shchd.com.tw

DRAWING TITLE		MATERIAL
<b>HEX WHEEL NUT</b>		<b>C10B21</b>
		<b>SAE J995 GRADE 8</b>
SURFACE <b>ZINCPLATING CR3</b>		
SCALE 2:1		SHEET 1 OF 1

4

3

2

1