



Project:

Item Number:

Quantity:

HEATED DISPLAY CABINETS



Heated Display Cabinets

MODELS

- 40845 HDE7136 36" Drop-in Display Cabinet
- 40846 HDE7148 48" Drop-in Display Cabinet
- 40847 HDE7160 60" Drop-in Display Cabinet
- 40855 HDE8136 36" Curved Glass Display Cabinet
- 40856 HDE8148 48" Curved Glass Display Cabinet
- 40857 HDE8160 60" Curved Glass Display Cabinet
- 40865 HDE8236 36" Cubed Glass Display Cabinet
- 40866 HDE8248 48" Cubed Glass Display Cabinet
- 40867 HDE8260 60" Cubed Glass Display Cabinet

FEATURES

- Inside lighting strips located both at the top of the cabinet and underneath the upper shelf create optimum food display throughout cabinet
- Dual fans circulate air throughout unit to ensure even temperature control
- Triple-glazed front glass gives added strength and insulation
- Drop-in and curved cabinets have two shelves. The cubed cabinet has 3 shelves
- Lift-and-remove rear sliding doors for easy display changes and end of day cleaning
- Digitally controlled thermostat for precise and consistent settings
- 104° - 158° F (40° to 70° C) temperature range
- Drop-in models can also be used as freestanding countertop units
- 6 ft. (1.8 m) 120v cord and plug
- Note: these items must ship by truck

DESCRIPTION

Vollrath's heated drop-in and countertop display cabinets enhance the presentation of hot food items. Sliding rear doors enable easy access for selling, refilling, changing displays and end-of-day cleaning.

WARRANTY: All models shown come with Vollrath's standard warranty against defects in materials and workmanship. For full warranty details, please refer to the Vollrath Equipment and Smallwares Catalog.

CLEARANCE REQUIREMENTS

- Drop-in cabinets require a minimum of 6" (15.2 cm) of non-combustible countertop to support the unit and a minimum of 6" (15.2 cm) clearance on all sides of the drop-in for proper air circulation.
- Countertop cabinets require a minimum of 6" (15.2 cm) between the equipment and any surrounding walls. Surrounding walls must be made of non-combustible materials.

Agency Listings



Due to continued product improvement, please consult www.vollrathco.com for current product specifications.

Approvals	Date



Setting the Standard™

www.vollrathco.com

The Vollrath Company, L.L.C.
 1236 North 18th Street
 Sheboygan, WI 53081-3201 U.S.A.
 Customer Service: 800.628.0830
 Canada Customer Service: 800.695.8560
 Main Fax: 800.752.5620 or 920.459.6573

Technical Services: 800.628.0832
 Technical Services Fax: 920.459.5462

HEATED DISPLAY CABINETS

MODELS	40845 HDE7136 36" Drop-in Display Cabinet	40857 HDE8160 60" Curved Glass Display Cabinet
	40846 HDE7148 48" Drop-in Display Cabinet	40865 HDE8236 36" Cubed Glass Display Cabinet
	40847 HDE7160 60" Drop-in Display Cabinet	40866 HDE8248 48" Cubed Glass Display Cabinet
	40855 HDE8136 36" Curved Glass Display Cabinet	40867 HDE8260 60" Cubed Glass Display Cabinet
	40856 HDE8148 48" Curved Glass Display Cabinet	

DIMENSIONS

Dimensions shown in inches (cm).

Drop-in Display Cabinets

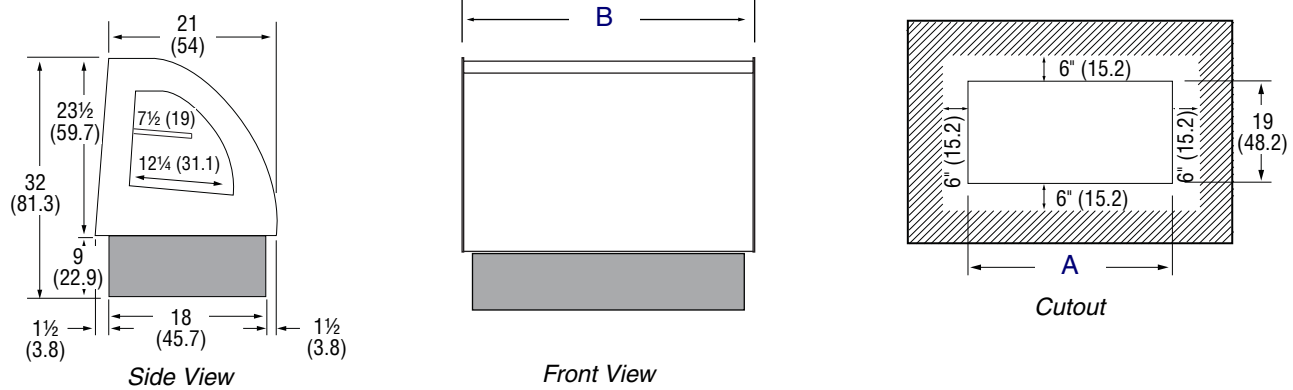

Curved Display Cabinets

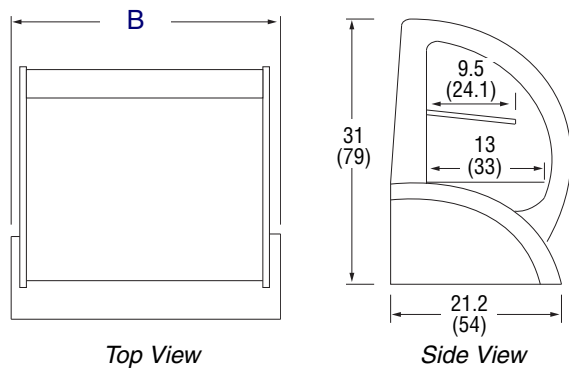

Cubed Display Cabinets

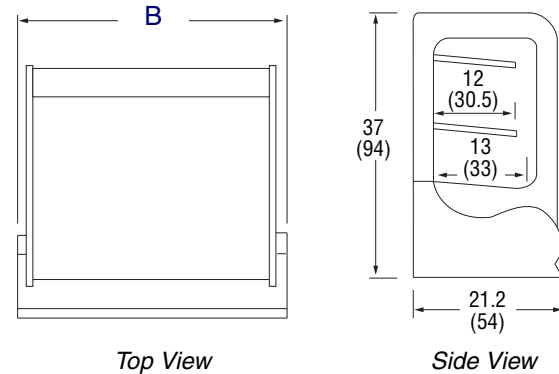

SPECIFICATIONS

Item	(A) Cutout Width	(B) Width	Watts	Volts	Amps	Weight lb (kg)	Plug
40845	34 (86.3)	36 (91.4)	670	120V AC	5.6	191 (86.6)	5-15P
40846	45 (114.3)	48 (121.9)	710	120V AC	5.9	232 (105.2)	5-15P
40847	58 (147.3)	60 (152)	750	120V AC	6.3	269 (122)	5-15P
40855	-	35 ⁷ / ₁₆ (90)	670	120V AC	5.6	183 (83)	5-15P
40856	-	47 ³ / ₁₆ (119.9)	710	120V AC	5.9	221 (100.2)	5-15P
40857	-	59 (149.9)	750	120V AC	6.3	263 (119.2)	5-15P
40865	-	35 ⁷ / ₁₆ (90)	730	120V AC	6.1	220 (99.8)	5-15P
40866	-	47 ³ / ₁₆ (119.9)	790	120V AC	6.6	270 (122.5)	5-15P
40867	-	59 (149.9)	850	120V AC	7.1	316 (143.3)	5-15P

Receptacle

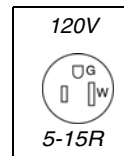

The Vollrath Company, L.L.C.
 1236 North 18th Street
 Sheboygan, WI 53081-3201 U.S.A.
 Customer Service: 800.628.0830
 Canada Customer Service: 800.695.8560
 Main Fax: 800.752.5620 or 920.459.6573

Technical Services: 800.628.0832
 Technical Services Fax: 920.459.5462