

# IS-950

## 2021-2025 FORD TRANSIT 45-GALLON MIDSHIP REPLACEMENT GAS TANK FOR 31GAL OEM FUEL SYSTEM ONLY

TFI PN: 080-01-17272

REV: E REVIEW DATE: 11/25/2025

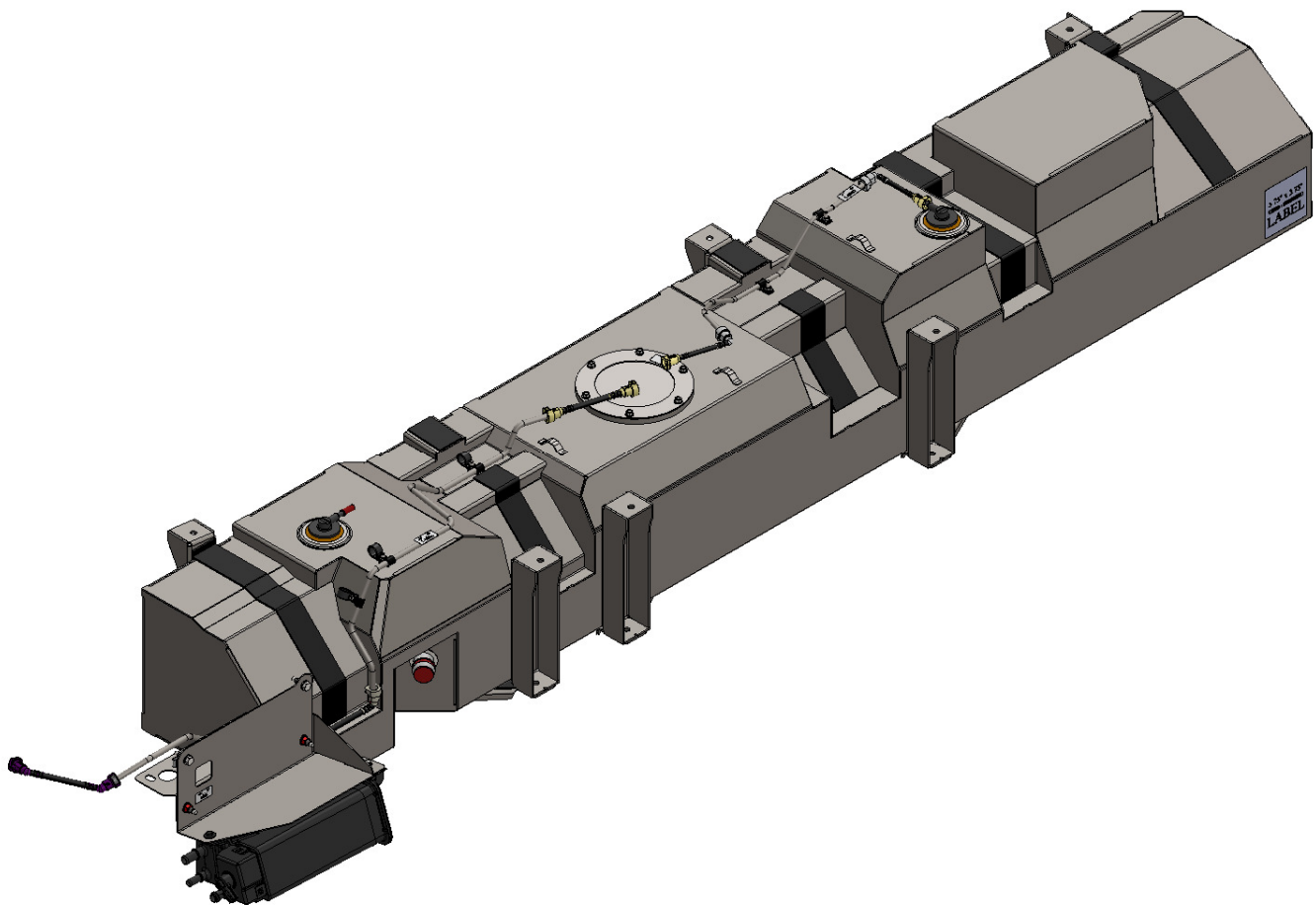

1444 Fortress Street, Chico CA 95973 • 1(800) 442-0056 / (530) 893-5209 • Fax (530) 893-0204  
[www.TransferFlow.com](http://www.TransferFlow.com)

# FORWARD & LEGAL NOTICE

Thank you for purchasing a Transfer Flow 45-gallon Midship Replacement Gasoline Fuel Tank System for your 2021-2025 Ford Transit. Please read the following procedures carefully before starting the installation.

This manual provides the necessary information for the installation of a Transfer Flow fuel system onto your vehicle. The information and instructions contained within this document are based on our annual model year signoffs. We update our instruction sheets based on information obtained during these model year signoffs as well as information provided by OEM companies and our customers. Changes to installation instructions may be made at any time without notice. If you find something we missed or require any additional information, please feel free to contact our Technical Support team at (800) 442-0056 ext. 2.

Transfer Flow fuel systems and parts are intended to be used in conjunction with the original manufacturer's equipment or Transfer Flow systems and components.

Our systems and components are not intended to be used in conjunction with other aftermarket fuel systems. Attempting to use our products inappropriately may lead to malfunction and voids the warranty. To ensure that your transfer flow products perform appropriately for many years to come, we ask that you follow these guidelines.

This product is protected by state or common law, copyright, trademark(s), and/or patent(s). All legal rights therein are reserved. The design, layout, dimensions, geometry, and engineering features shown in this product are the exclusive property of Transfer Flow. This product may not be copied or duplicated in whole or part, abstractly or fundamentally, intentionally or fortuitously, nor shall any design, dimension, or other information be incorporated into any product or apparatus without the prior written consent of Transfer Flow.

## SAFETY NOTES

Please read these installation instructions entirely prior to beginning the installation of the Transfer Flow fuel system. If you would prefer your fuel system be professionally installed, please contact your local dealer, or browse our list of dealers in your area on our website at [www.TransferFlow.com/installation](http://www.TransferFlow.com/installation).

Transfer Flow fuel systems are designed for use on stock OEM vehicles. We do our best to foresee how our customers will use and modify their vehicles, but unfortunately, we cannot verify all aftermarket modifications. If your vehicle has had any modifications to the chassis, suspension, fuel system, truck bed, or wheel/tire size that differs from stock, please call Transfer Flow before installing one of our fuel systems.

- Work in a well-ventilated area.
- Always wear safety glasses.
- The Transfer Flow fuel tank is heavy, please use proper lifting techniques when handling the tank.



**CAUTION: DO NOT HAVE ANY OPEN FLAME OR HEAT SOURCE CLOSE TO THE INSTALLATION AREA.**



**CAUTION: DO NOT OVERFILL FUEL TANK.**

## TABLE OF CONTENTS

<b>REQUIRED TOOLS &amp; SUPPLIES.....</b>	<b>4</b>
<b>PARTS LIST/DIAGRAM .....</b>	<b>5</b>
<b>INSTALLATION INSTRUCTIONS .....</b>	<b>6</b>
<b>SECTION 1: REMOVE THE OEM FUEL SYSTEM.....</b>	<b>6</b>
<b>SECTION 2: INSTALLING THE TFI EMISSIONS CANISTER AND CANISTER BRACKETS.....</b>	<b>18</b>
<b>SECTION 3: RELOCATING THE OEM WIRE HARNESS CUTAWAY/CAB CHASSIS VANS ONLY .....</b>	<b>28</b>
<b>SECTION 4: PREPARING THE REPLACEMENT TANK .....</b>	<b>31</b>
<b>SECTION 5: PRESSURE TESTING THE REPLACEMENT TANK .....</b>	<b>35</b>
<b>SECTION 6: INSTALLING THE REPLACEMENT TANK.....</b>	<b>36</b>
<b>SECTION 7: INTSTALLING THE OEM EMISSIONS CANISTER AND TFI VAPOR LINES .....</b>	<b>40</b>
<b>SECTION 8: SECURE THE OEM WIRE HARNESS CUTAWAY/CAB CHASSIS VANS ONLY .....</b>	<b>43</b>
<b>SECTION 9: FINALIZING THE INSTALLATION .....</b>	<b>45</b>

## **REQUIRED TOOLS & SUPPLIES**

Before starting the installation process, review the entire installation instructions. If you have any questions regarding the fuel system or the installation process, please contact Transfer Flow at (800) 442-0056.

- Safety glasses
- Air compressor
- Air nozzle
- Spray bottle with soapy water
- Catch pan or spill mats
- OEM Owner's Manual
- 15mm open end wrench
- 7mm socket
- 10 mm socket
- 15mm socket
- Torx T30 bit for socket wrench
- Pneumatic or Electric Impact gun
- 1/4" drive socket extensions
- 1/2" drive socket extensions
- Hydraulic jack
- 0-50 ft-lb torque wrench
- 1/4" Drive Ratchet
- 1/2" Drive Ratchet
- Flat screwdriver or small prybar
- Multimeter

## PARTS LIST/DIAGRAM

Before beginning installation, verify all parts shown below are included in the installation kit. If there are any missing or damaged parts, please contact Transfer Flow at (800) 442-0056.

- 080-01-17272 45-gallon Ford 2021-2025 Transit Midship Replacement Fuel Tank System
  - 020-01-17274 Tank Assembly Kit
  - 020-01-17296 Base Installation Kit
  - 020-01-17293 31gal OEM Tank Replacement Kit
  - IS-484 Torque Specifications
  - IS-642 Weight List
  - IS-946 CARB Aftermarket Parts Label
- Required Purchased Part(s):
  - 020-01-17275 Passenger Van Strap Kit (left) **OR** 020-01-17295 Cutaway Van Strap Kit (right)

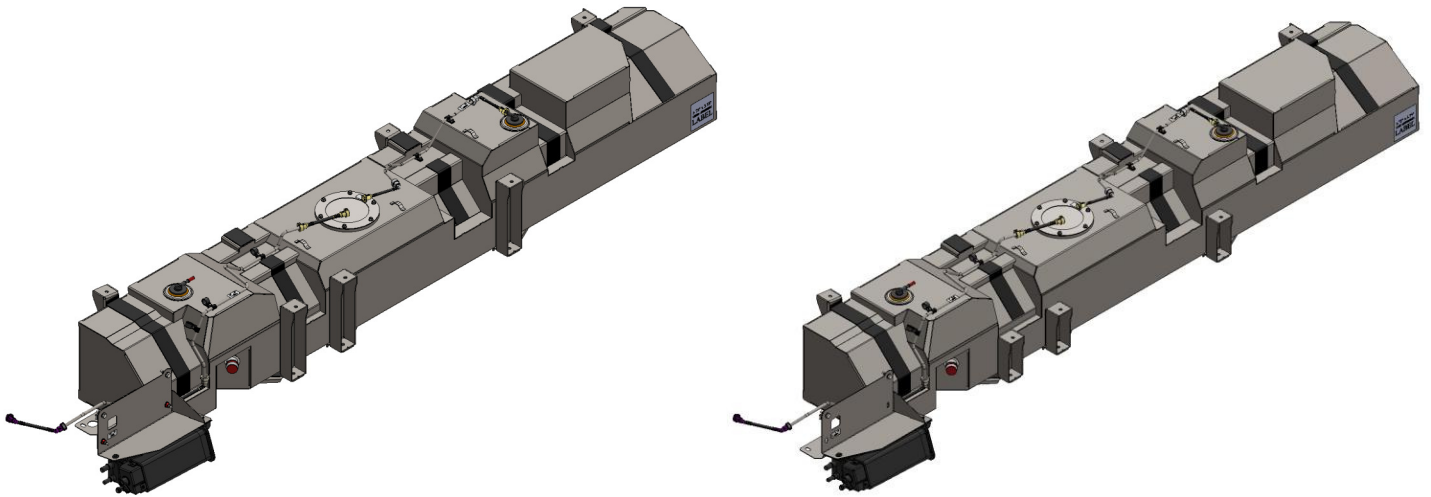

## FLOAT WIRE/FUEL GAUGE CALIBRATION

Fuel Gauge	Gallons
EMPTY	2
$\frac{1}{4}$	10
$\frac{1}{2}$	23
$\frac{3}{4}$	32
FULL	45



**Due to the increased capacity of the Transfer Flow replacement fuel system, the vehicle's "Distance to Empty" (DTE) reading will no longer be accurate.** The provided table lists the approximate fuel gauge position and fuel volume readings for the Transfer Flow replacement fuel system. These values may vary depending on gauge and sender tolerances.

## INSTALLATION INSTRUCTIONS

### SECTION 1: REMOVE THE OEM FUEL SYSTEM

1. Park the vehicle in the desired location and engage the parking brake.
2. Turn the key to the “off” position.
3. Release the fuel system pressure.
  - a. Disconnect the Fuel Pump Control Module electrical connector located above the fuel tank and along the driver’s side frame rail.
  - b. Start the engine and allow it to idle until it stalls.
  - c. After the engine stalls, crank the engine for approximately five seconds to ensure that the fuel rail pressure has been released.
4. Turn the key to the “off” position.

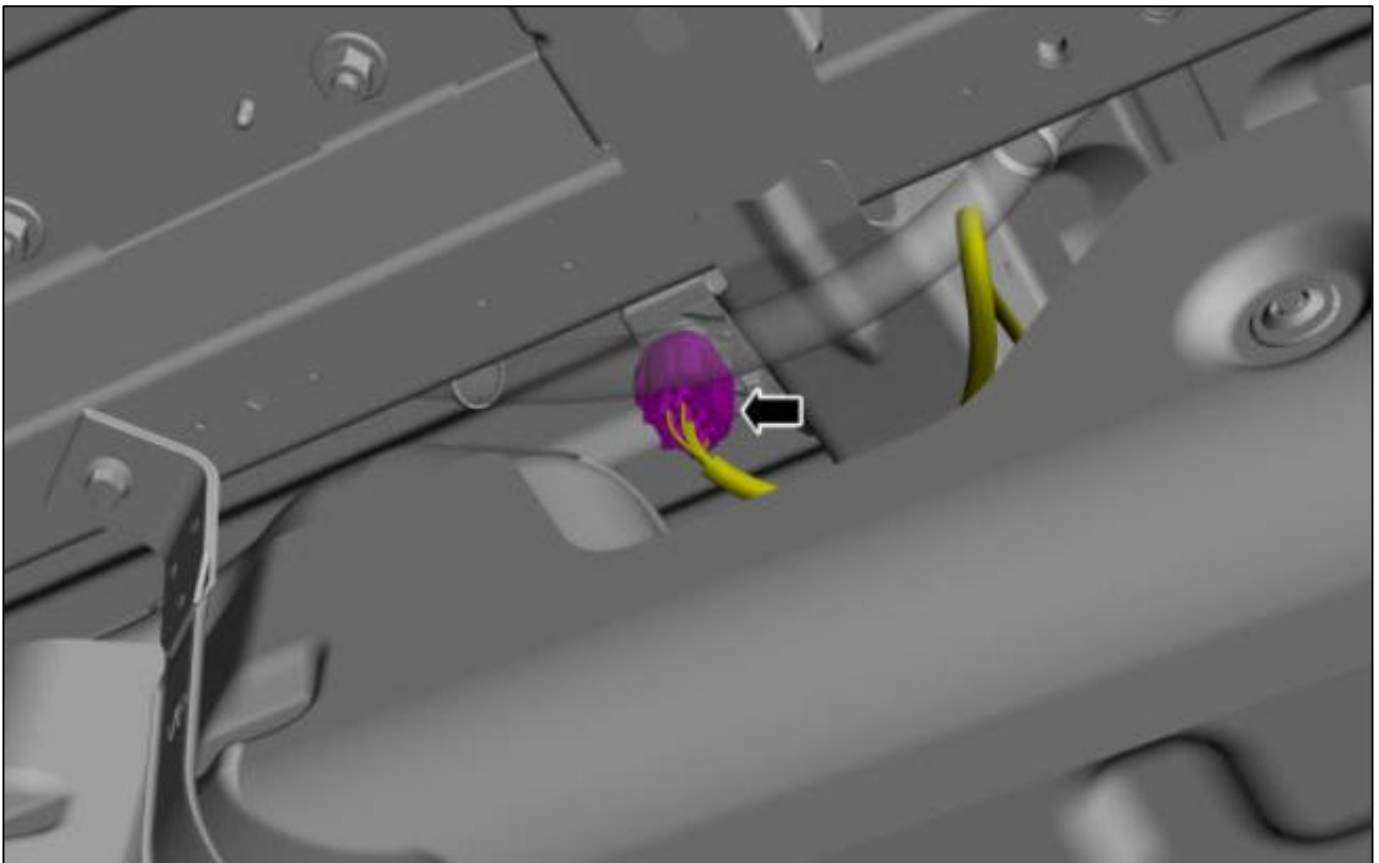

5. Disconnect the primary. Loosen and remove the negative terminal connector then remove positive terminal connector.
6. If available, disconnect the secondary battery. Loosen and remove the negative terminal connector, then remove positive terminal connector.

7. Remove Intermediate Canister Tube Assembly by disconnecting the quick-connect fittings attached to the Primary and Secondary OEM Canisters. Retain this part, as it will be reinstalled after the replacement tank has been installed.
8. Remove the Secondary OEM Canister.
  - a. Disconnect the quick-connect fitting that connects to the Fresh Air Vent Line.
  - b. Disconnect the Fresh Air Vent Valve Electrical Connector from the front of the Secondary OEM Canister.
  - c. Remove the 2 bolts with 13mm socket and socket drive, then remove the canister assembly. Retain this part, as it will be reinstalled after the replacement tank has been installed.

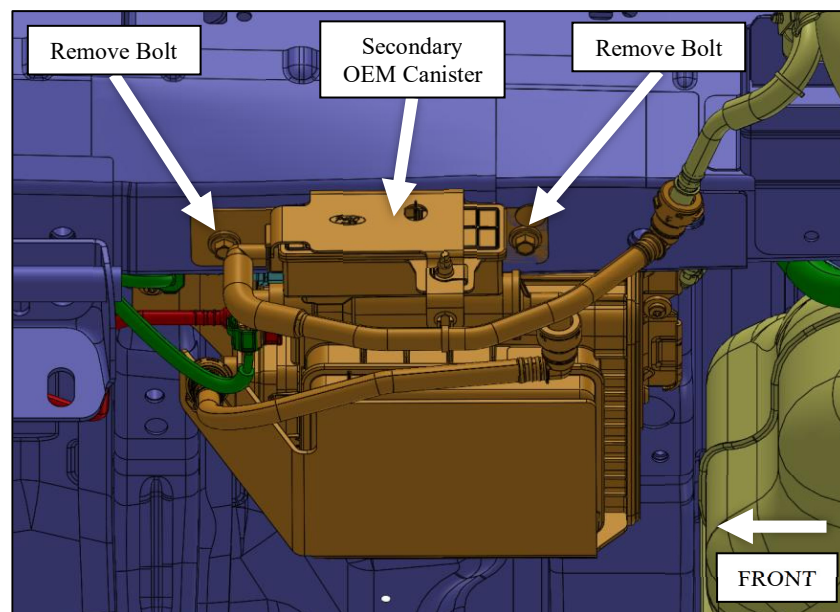
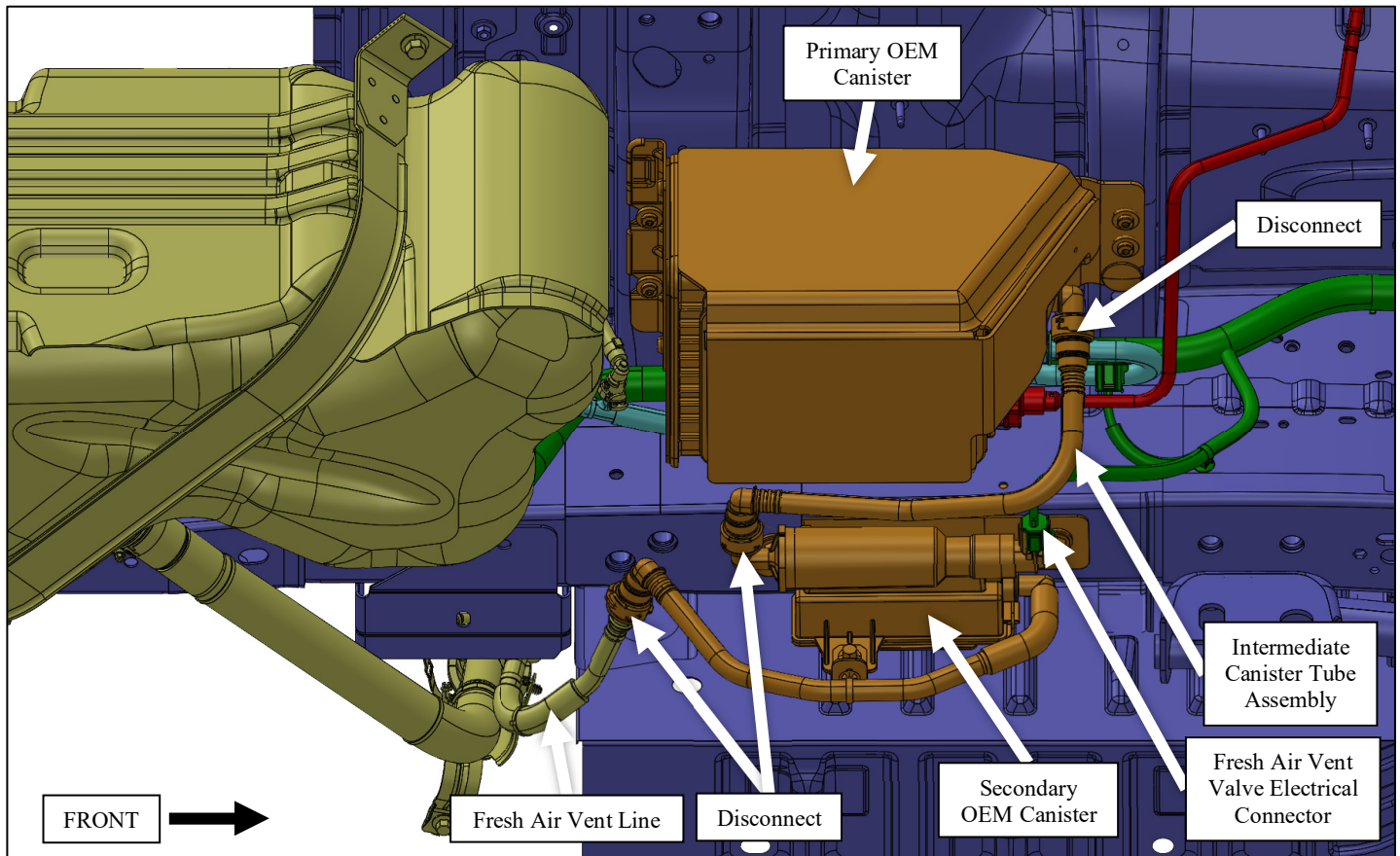

9. Remove the Primary OEM Canister.
  - a. Loosen the rear two bolts with a Torx T30, socket drive, and socket extensions. Do not remove the bolts, as they will help hold the canister in place while hoses are disconnected.
  - b. Remove the front two bolts with Torx T30, socket drive, and socket extensions. Retain the hardware.
  - c. While carefully lowering the canister, disconnect the two quick-connect fittings at the front of the canister. Carefully move the Canister Purge Line and Tank Vent Line out of the way while removing the canister. Retain this canister, as it will be reinstalled after the replacement tank has been installed.

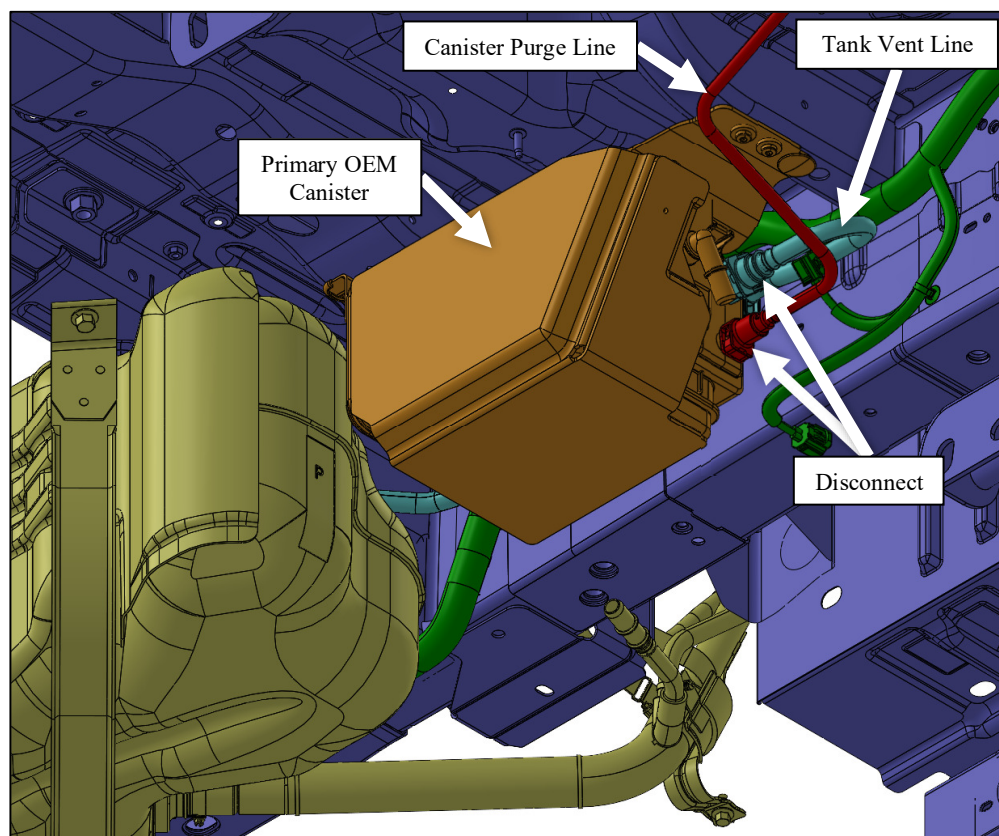
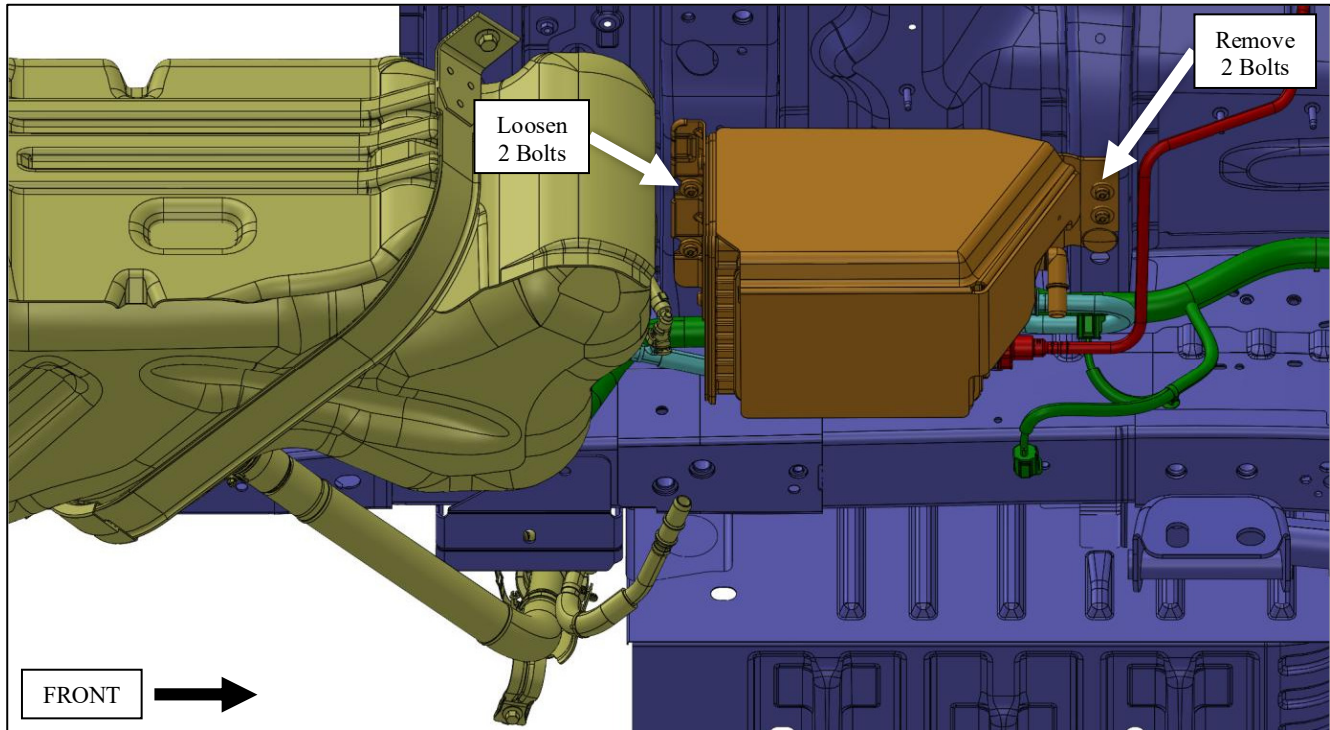

10. Unclip the two lines from the plastic clip, located between the inside of the driver's side frame rail OEM emissions canister.
11. Disconnect the fill neck vent line quick-connect fitting that is connected to the t-fitting between the front of the tank and the rear of the OEM emissions canister.

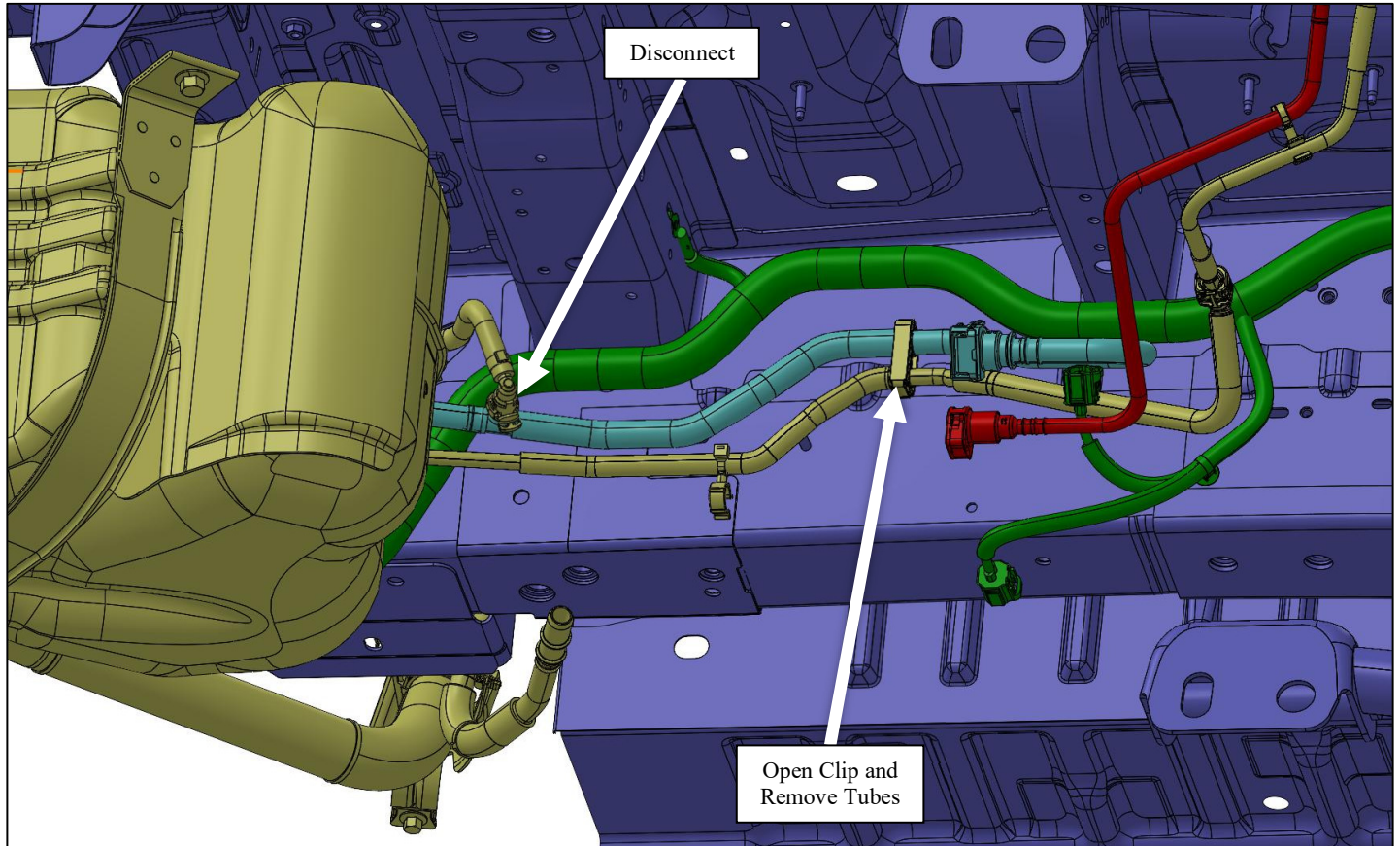

12. Disconnect the fuel line connectors located to the front of the fuel tank and OEM emissions canister. Wrap the fuel line connector with a shop towel to absorb any residual fuel leaks during the removal of the fuel line. Capture any leaking fuel with an appropriate catch pan.



**CAUTION: THE FUEL LINES MAY BE UNDER PRESSURE. WEAR THE APPROPRIATE PERSONAL PROTECTIVE EQUIPMENT. USE RAGS TO COVER THE SURROUNDING AREA AND A CATCH PAN TO CAPTURE THE GASOLINE THAT LEAKS FROM THE FUEL LINES.**

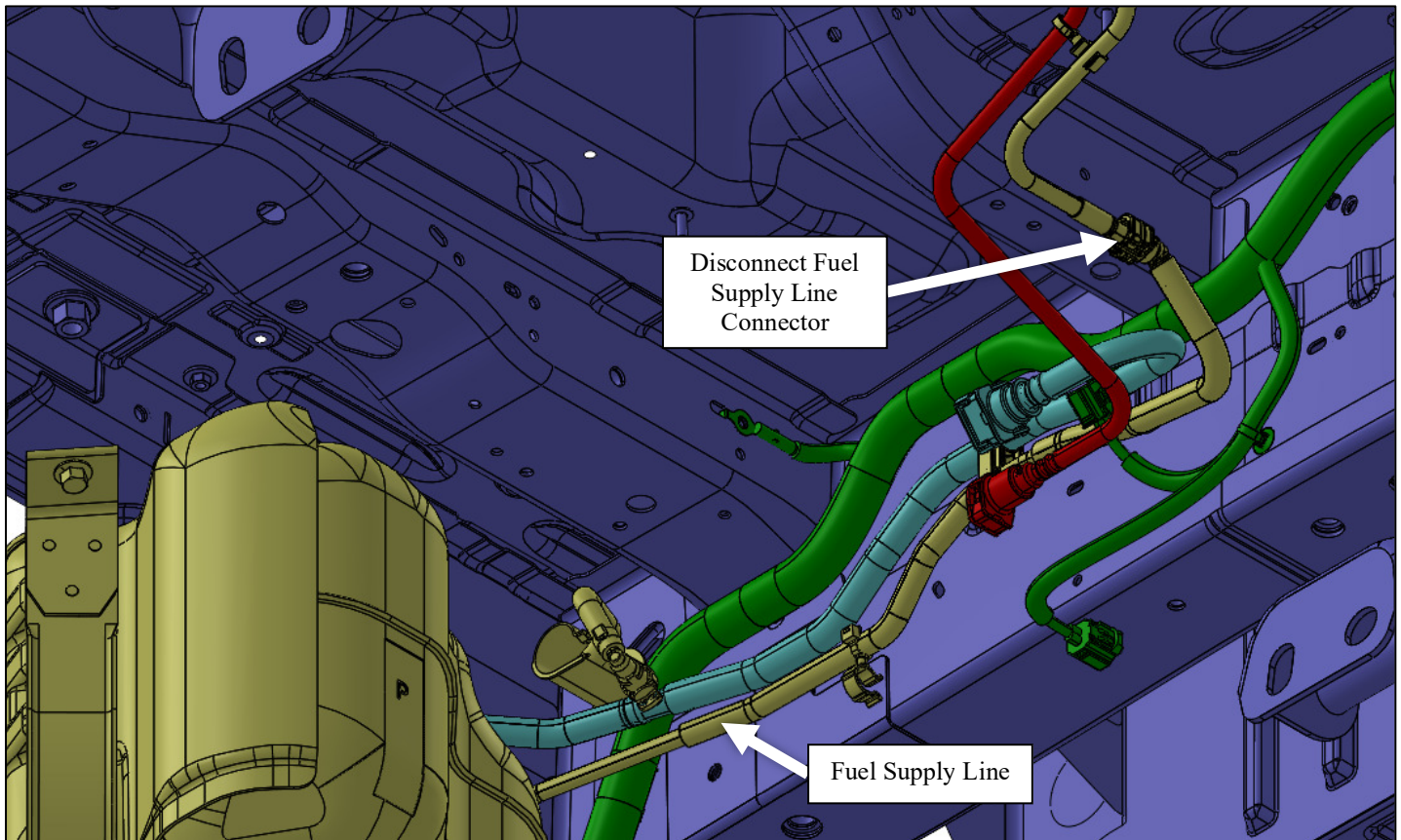

13. Disconnect and slowly remove the fuel line quick-connect fitting located on top of the engine.
  - a. Wrap each fuel line connector with a shop towel to absorb any residual fuel leaks during the removal of the fuel line.
  - b. Residual fuel may drain from the lower end of the fuel supply line that was previously disconnected. Use a catch can to capture the fuel and reduce the amount of fuel that can spill onto the ground.



**CAUTION: THE FUEL LINES MAY BE UNDER PRESSURE. WEAR THE APPROPRIATE PERSONAL PROTECTIVE EQUIPMENT. USE RAGS TO COVER THE SURROUNDING AREA AND A CATCH PAN TO CAPTURE THE GASOLINE THAT LEAKS FROM THE FUEL LINES.**

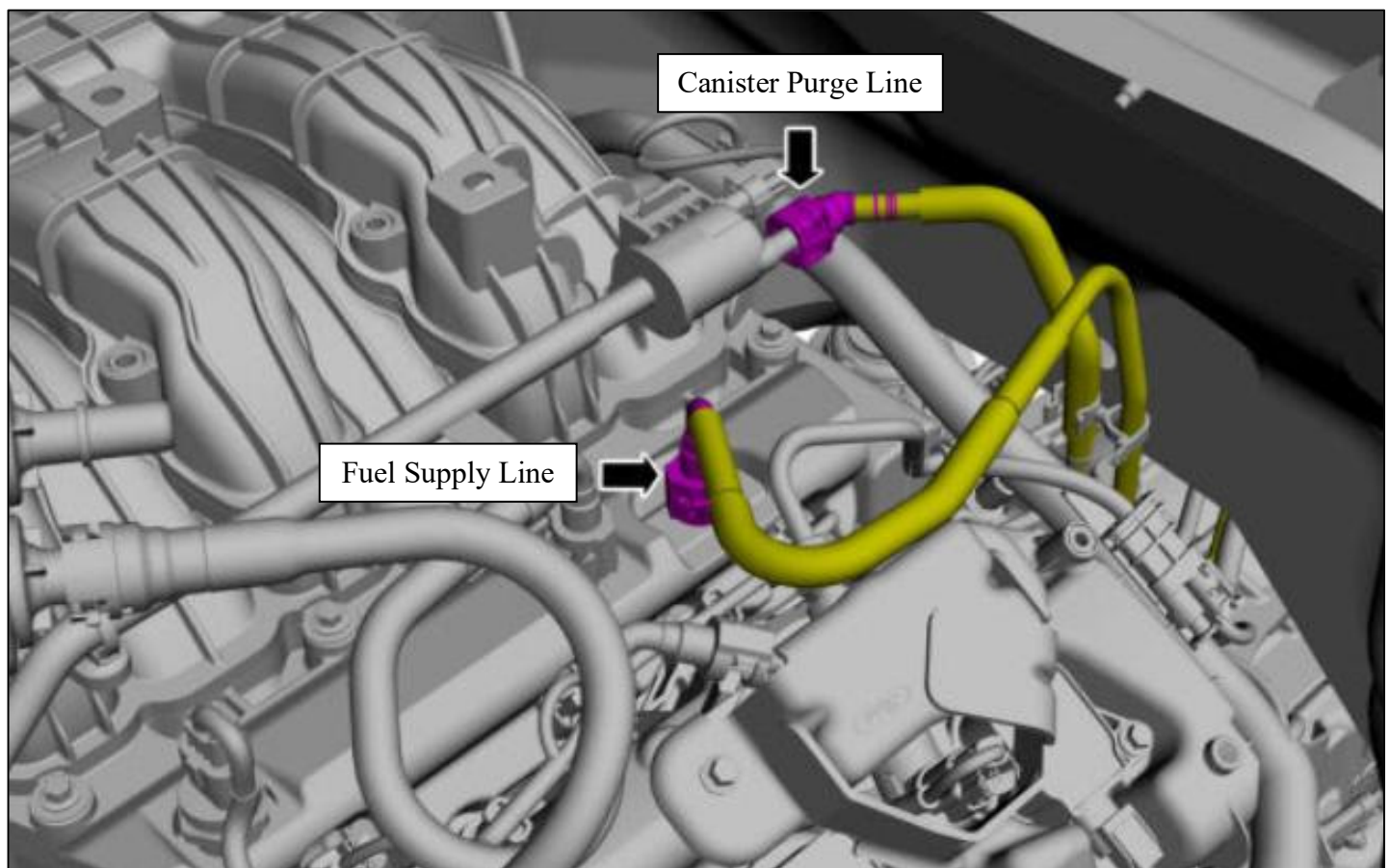

14. Loosen the gear clamp securing the rubber fuel fill tube to the fill neck. Leave the gear clamp on the rubber fill tube, as it will be reused when installing the new fuel tank.

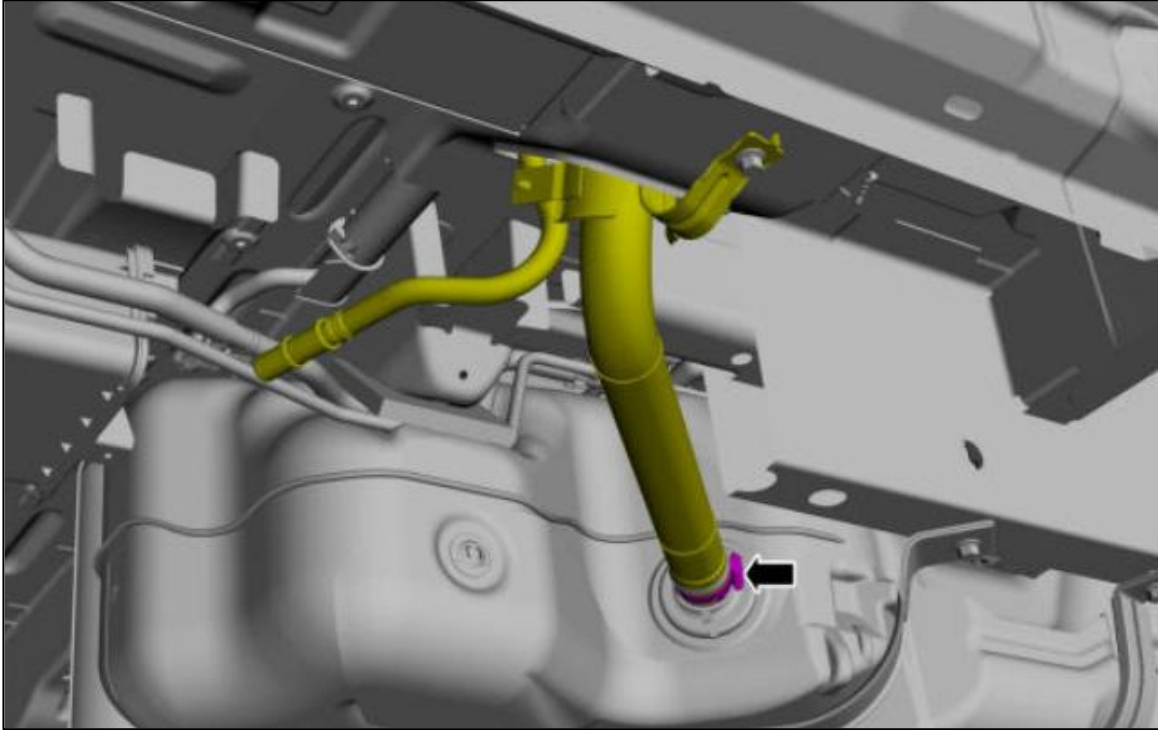

15. Support the fuel tank using a pneumatic or hydraulic jack.
16. Remove the (4) fuel tank straps.

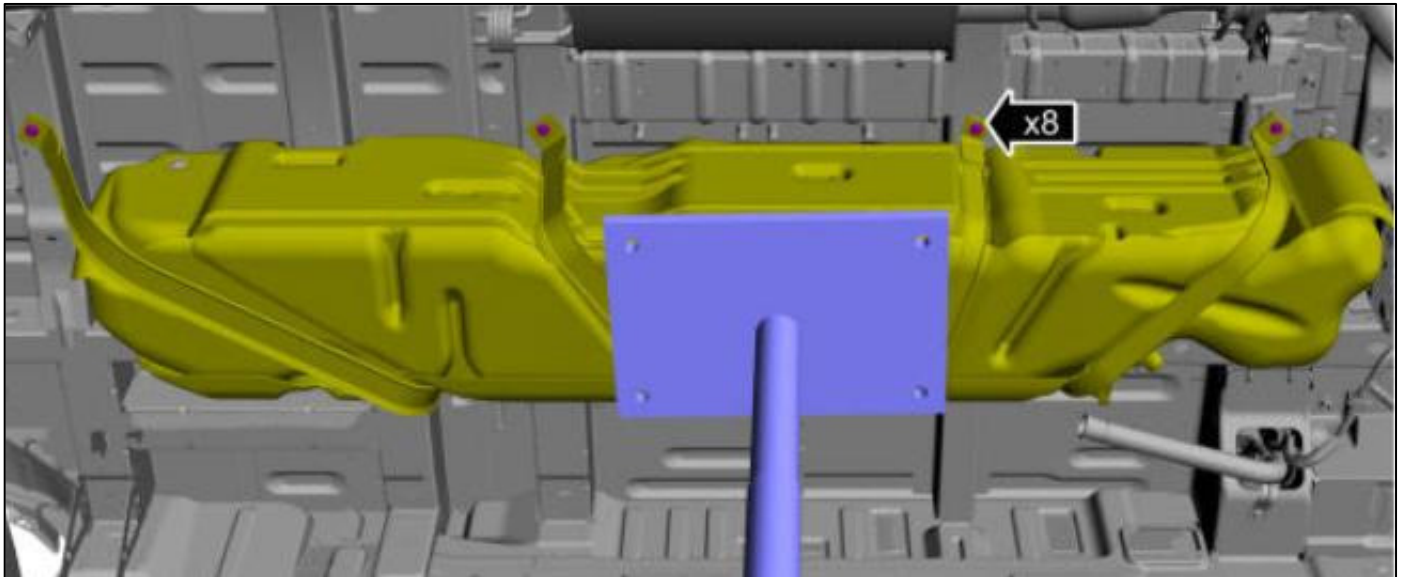

17. Slowly lower the fuel tank about 6 inches, making sure that the fuel and vapor at the front of the tank do not catch on any other parts of the vehicle.
18. Once there is access to the top of the fuel tank and sending unit, disconnect the sending unit and pressure sensor connectors.
  - a. If used, disconnect the generator fuel draw quick-connect fitting. Catch any fuel spills with shop rags and an appropriate catch pan.
  - b. Do not lower the fuel tank without disconnecting the electrical connectors, as this will damage the connectors and/or wire harness.

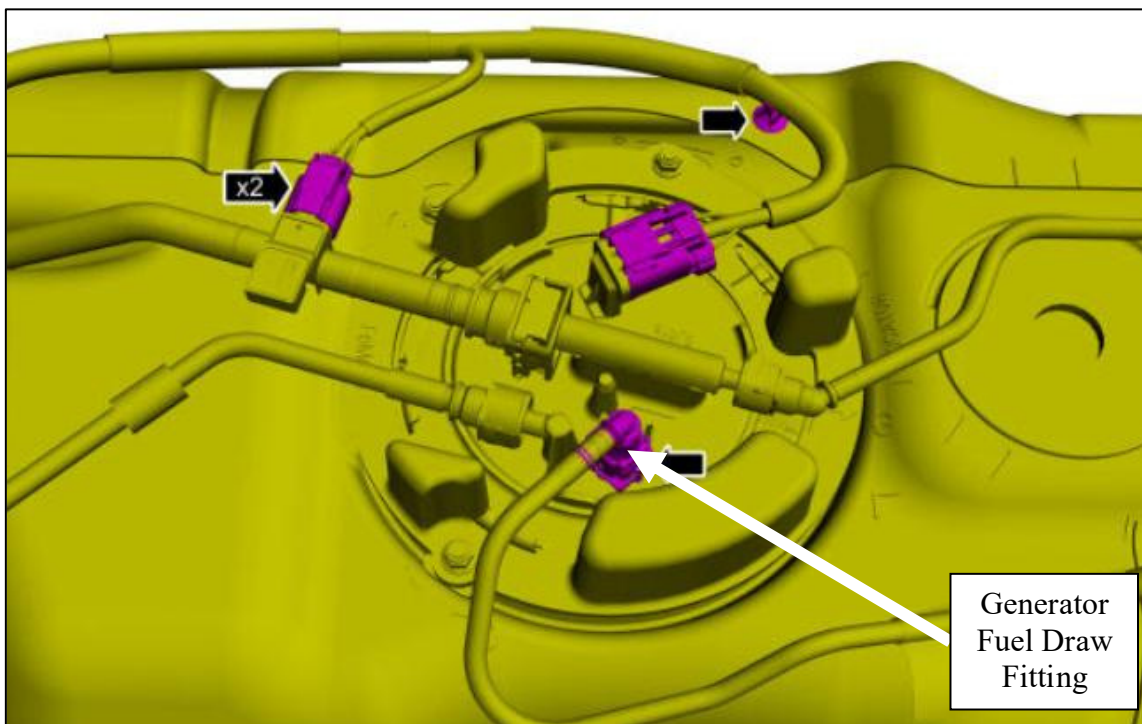
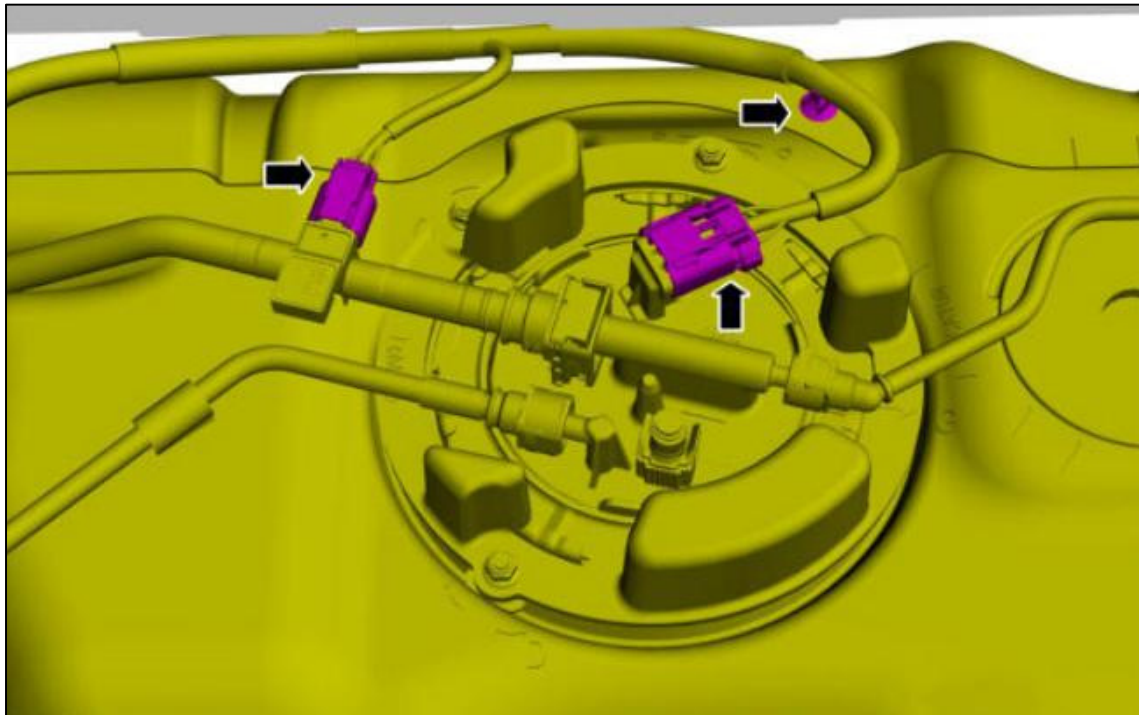

19. If used, detach the generator fuel line clip from the cross member.

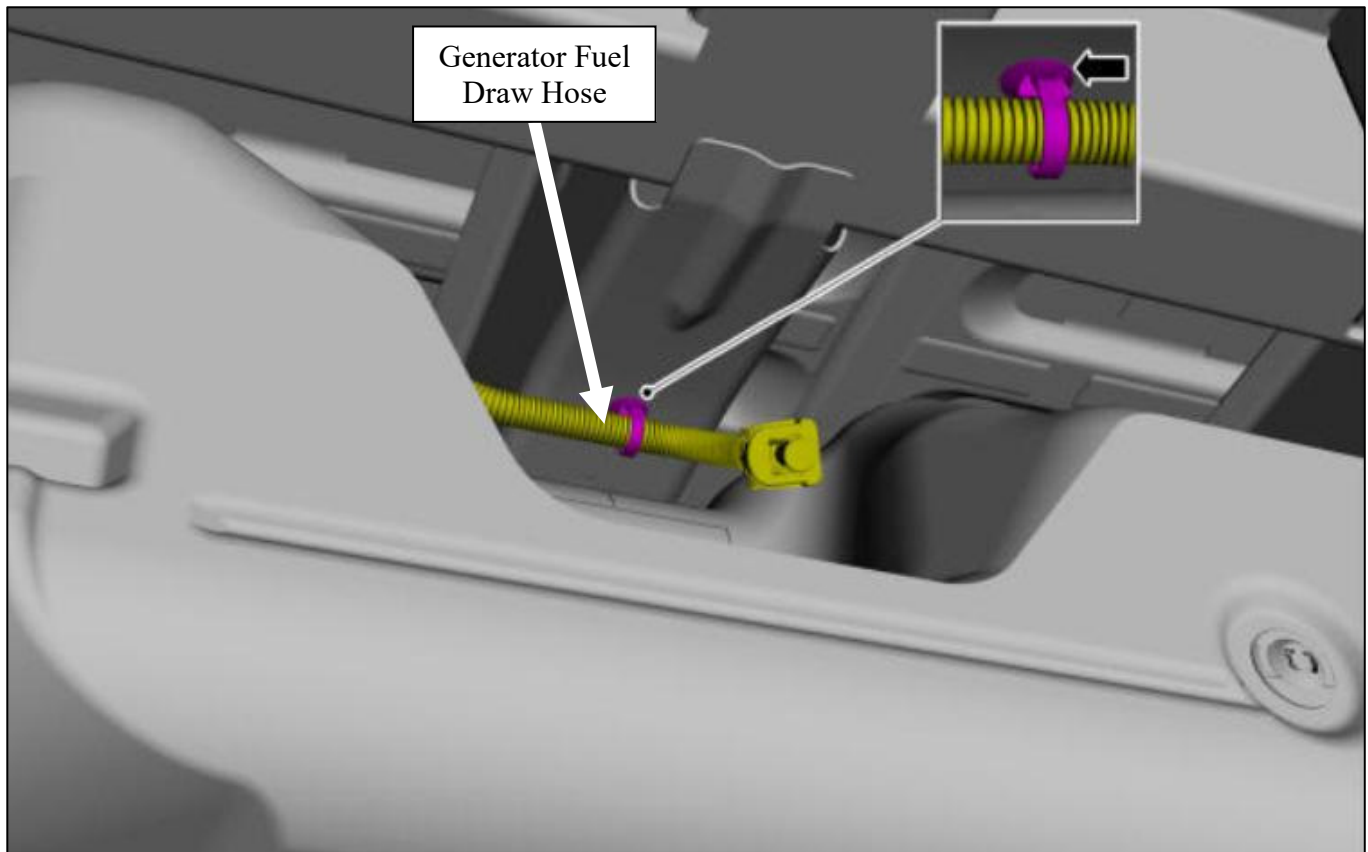

20. After all electrical, fuel, and vapor lines are clear, completely lower and remove the OEM fuel tank.

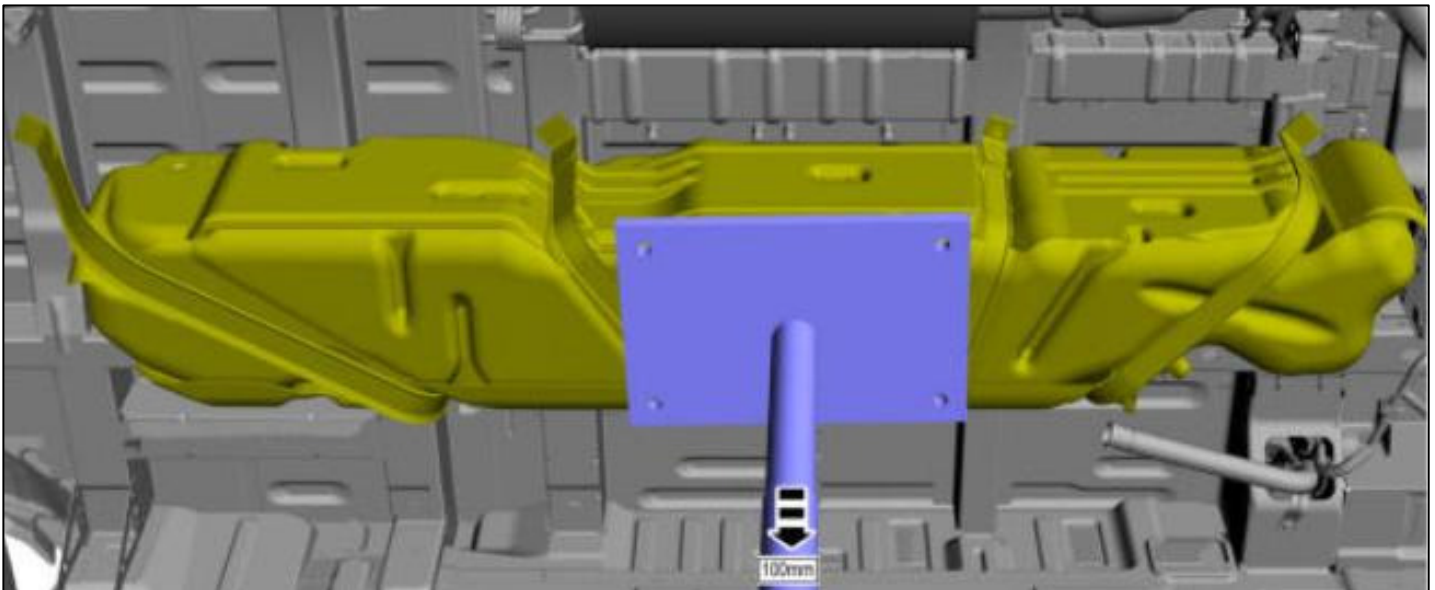

21. Disconnect the tank vent line from the front Roll Over Valve and the Sending Unit. Detach the clips that connect tank vent line and the fuel line. If used, remove the foam that covers the tank vent line at the front top of the tank. The tank vent line will be reused on the replacement system.
22. Disconnect and remove the fuel supply line from the sending unit.
23. Disconnect and remove the rear roll over valve line from the sending unit.
24. If used, disconnect and remove the generator fuel draw line from the sending unit.

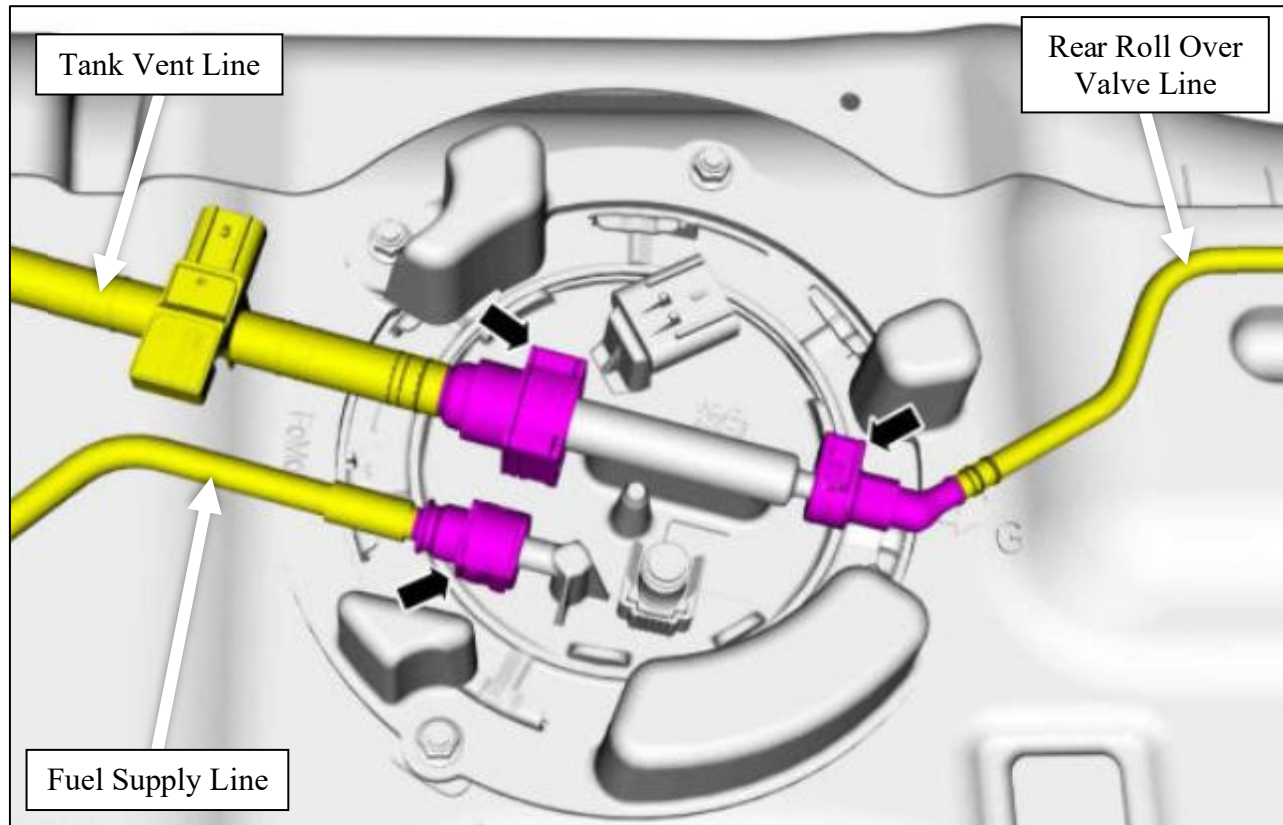

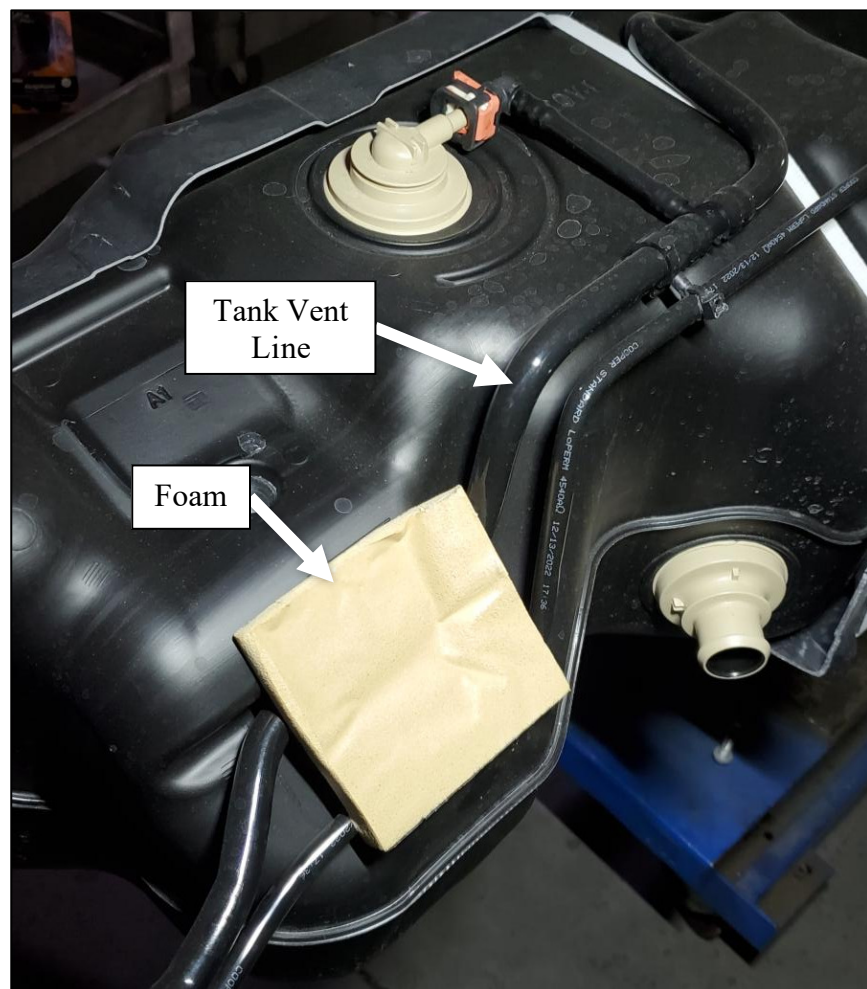
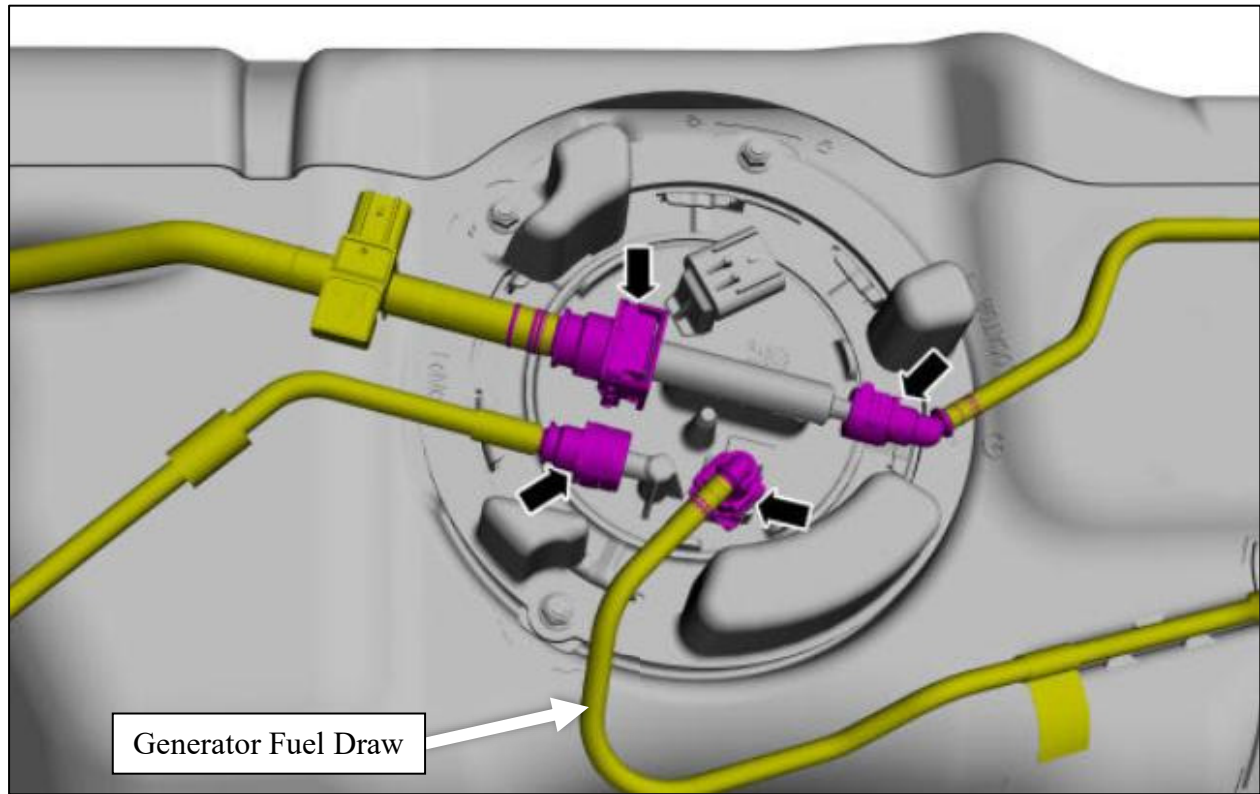

25. Remove and discard the sending unit ring cover by removing the 3 nuts.

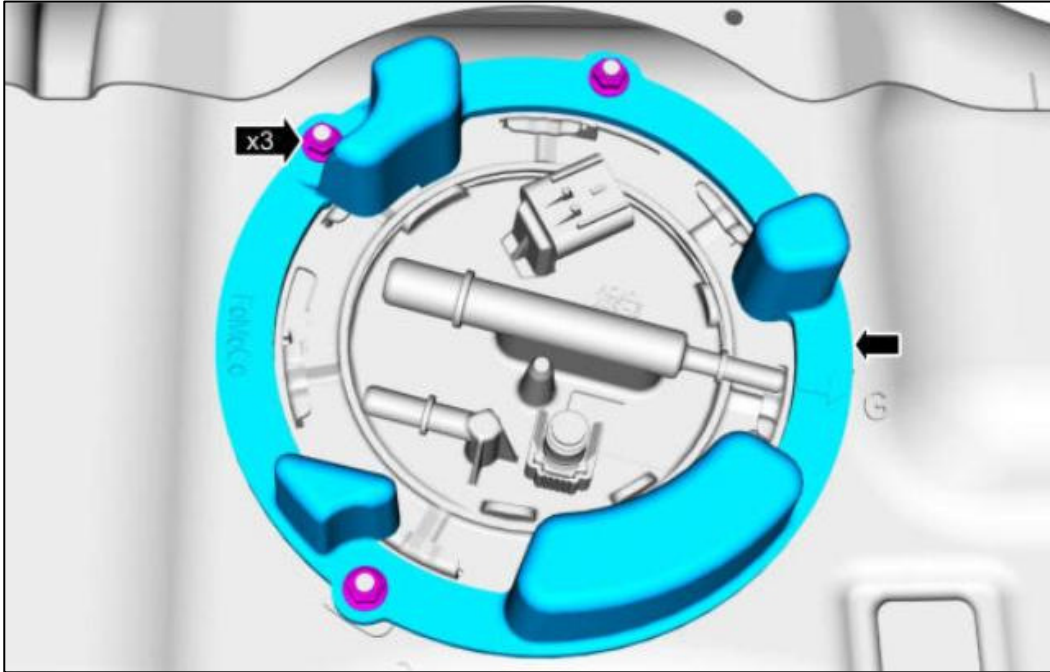

26. Remove the fuel sending unit from the OEM fuel tank.
- Remove the locking ring with SST 310-123 (if available), or by using a large flat head screwdriver/pry bar and mallet. Turn the ring counterclockwise until it unlocks.
  - Lift the sending unit up and slowly tip to allow fuel to drain. Then remove the sending unit from the tank while making sure to not bend the float wire.

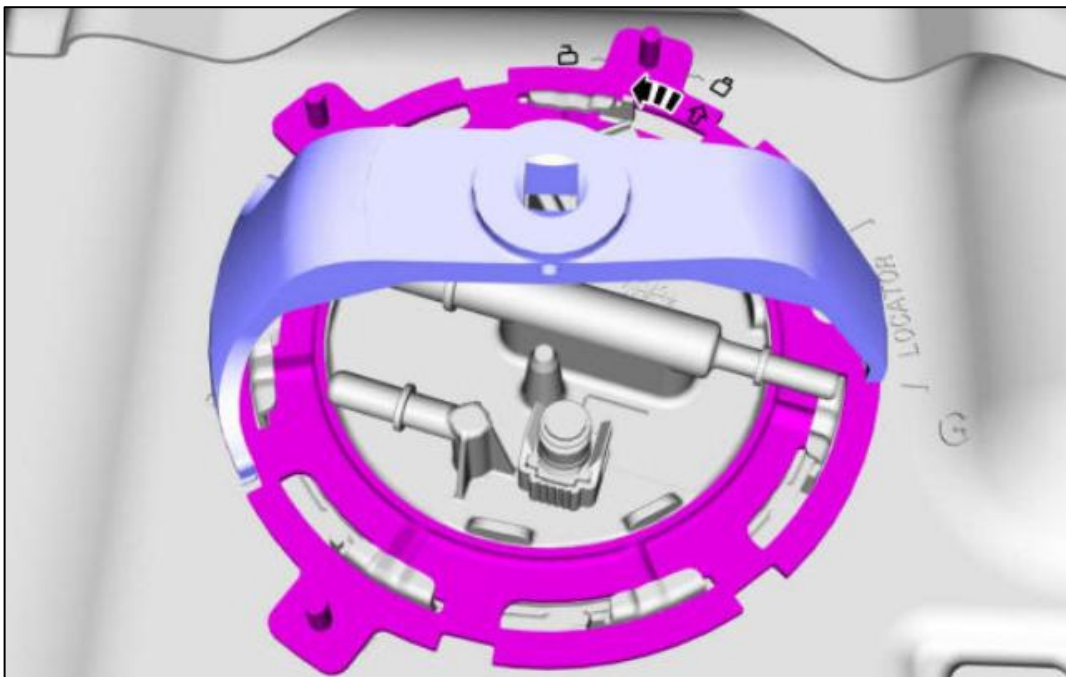

## **SECTION 2: INSTALLING THE TFI EMISSIONS CANISTER AND CANISTER BRACKETS**

1. Locate the Transfer Flow emissions canister bracket and two M8 clip nuts included in the installation kit parts bag.
2. Remove the OEM mounting bracket from the assembly. Retain the OEM bolt and clip nut, as it will be re-used.

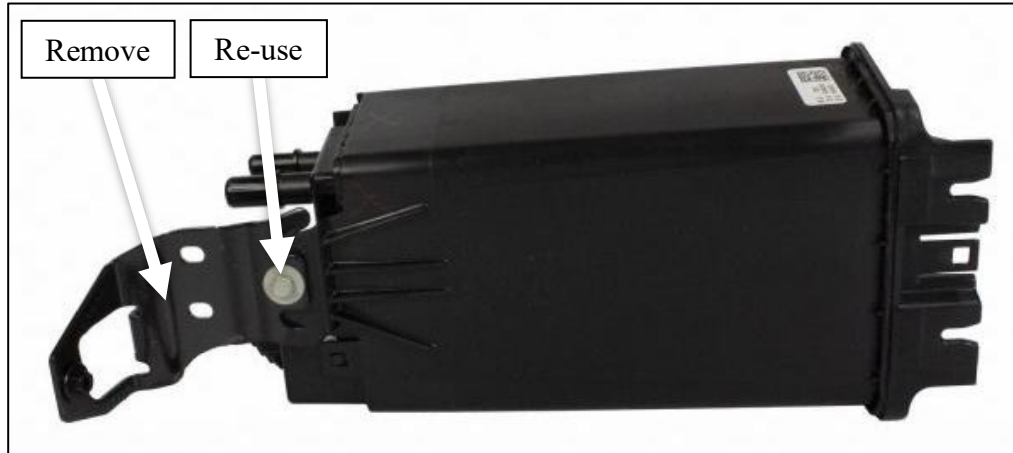

3. Mount the TFI Emissions Canister to the provided canister bracket(s).
  - a. Only tighten provided hardware such that it is “hand-tight” and can be adjusted for final fitment.
  - b. Do not install any hose assemblies at this time, unless noted otherwise. They will be installed after the tank is installed.

c. For Passenger Van chassis:

- i. Mount the front of the TFI Emissions Canister (TFI 070-CA-34571) to the TFI Canister Bracket (040-01-17276) using the OEM bolt (from Step 2). Torque to 5.5 ft-lbs.
- ii. Mount the rear of the TFI Emissions Canister with the supplied 1/4"-20 hardware. Use a 1/4" washer on each side of the joint. Place a washer between the head of the bolt and the TFI canister bracket, and between the 1/4"-20 nut and the plastic mounting tabs on the TFI Emissions Canister. Torque to 5.5 ft-lbs. Check that at least two threads are showing past the end of the nut.
- iii. Mount the TFI Passenger Van Canister Bracket (TFI 040-01-17344) to the TFI Canister Bracket (040-01-17276) using the provided hardware. Only tighten to "hand-tight".

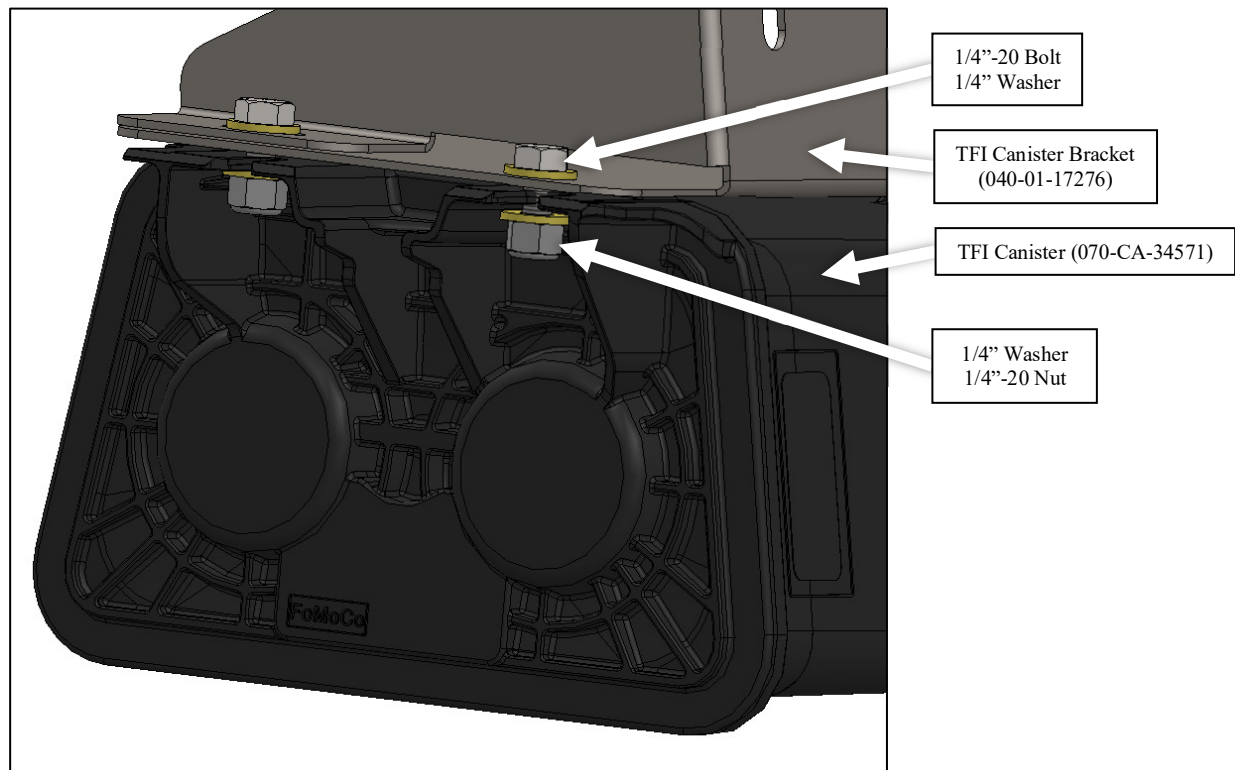
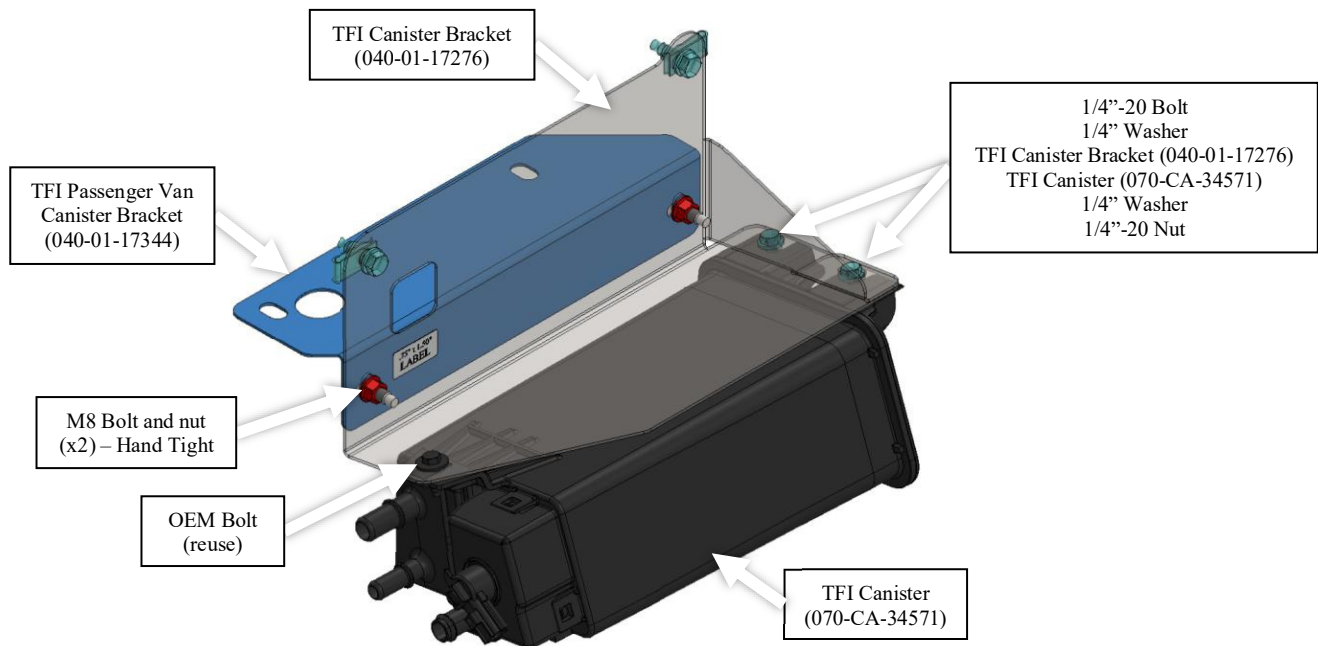

d. For Cutaway Van chassis:

- i. Mount the TFI Cutaway Van Canister Bracket (040-01-17345) between the TFI Canister Bracket (040-01-17276) and TFI Emissions Canister (TFI 070-CA-34571).
- ii. Mount the front of the TFI Emissions Canister using the OEM bolt (from Step 2). Torque to 5.5 ft-lbs.
- iii. Mount the rear of the TFI Emissions Canister with the supplied 1/4"-20 hardware. Use a 1/4" washer on each side of the joint. Place a washer between the head of the bolt and the TFI canister bracket, and between the 1/4"-20 nut and the plastic mounting tabs on the TFI Emissions Canister. Torque to 5.5 ft-lbs. Check that at least two threads are showing past the end of the nut.

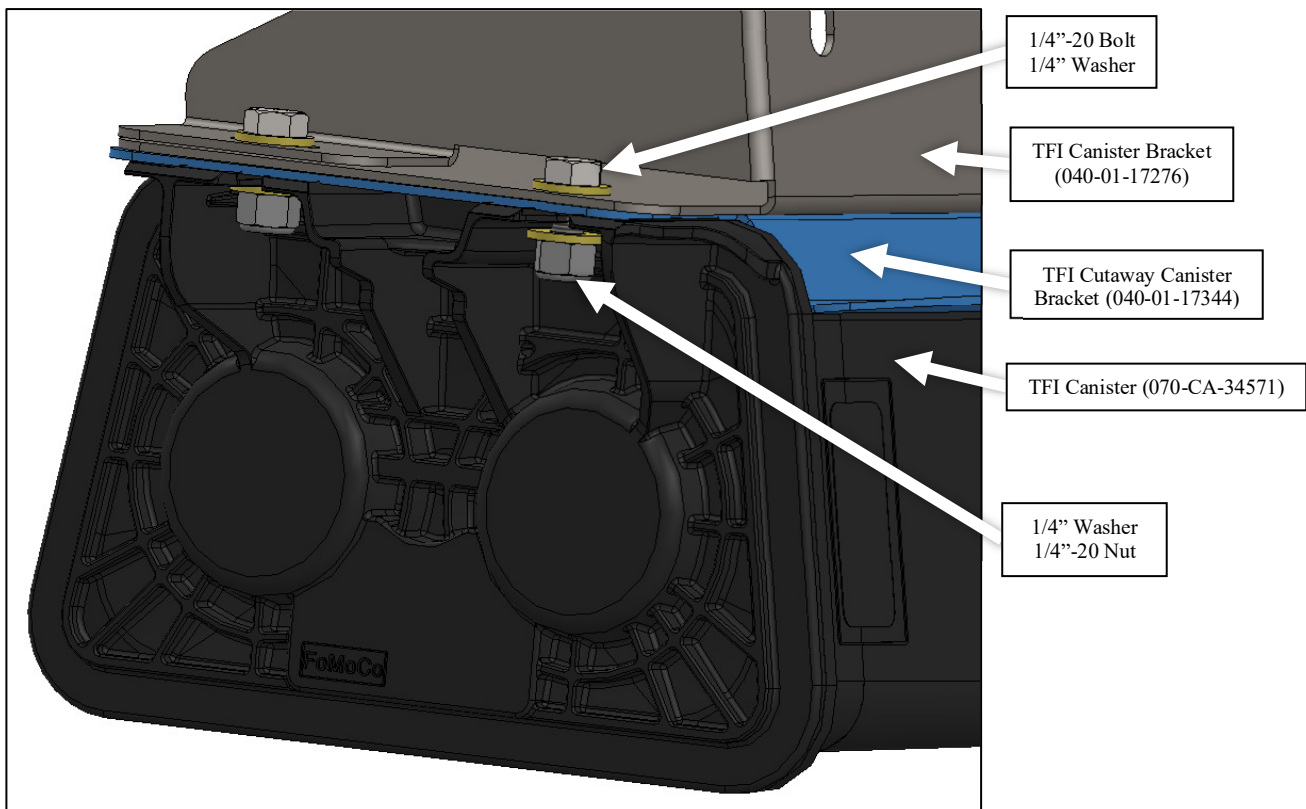
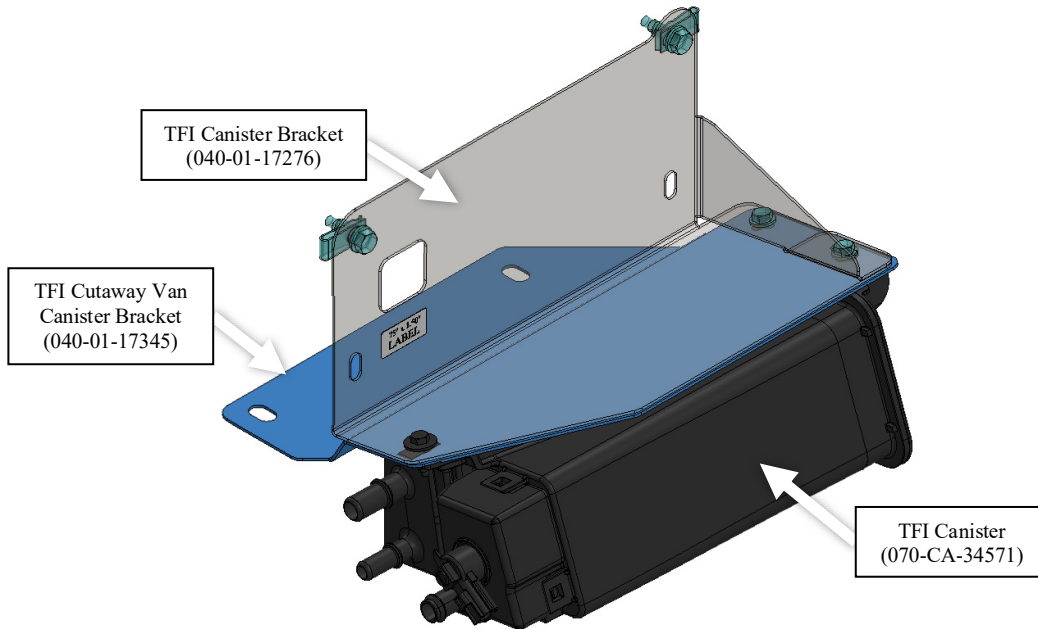

- 4. Insert the two provided M8 clip nuts into the frame on the outside, drivers side frame rail.
  - a. For Passenger Van chassis:

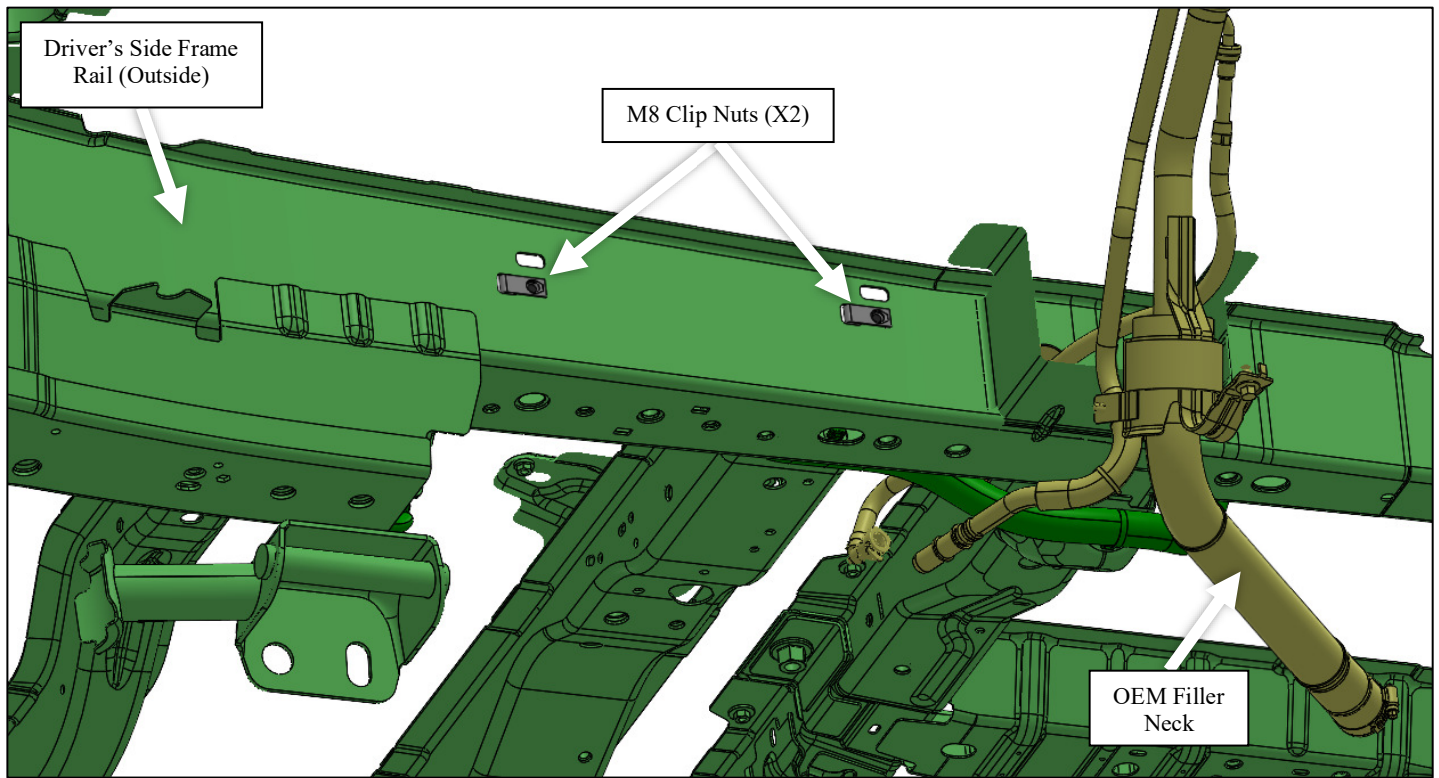

- b. For Cutaway Van chassis:

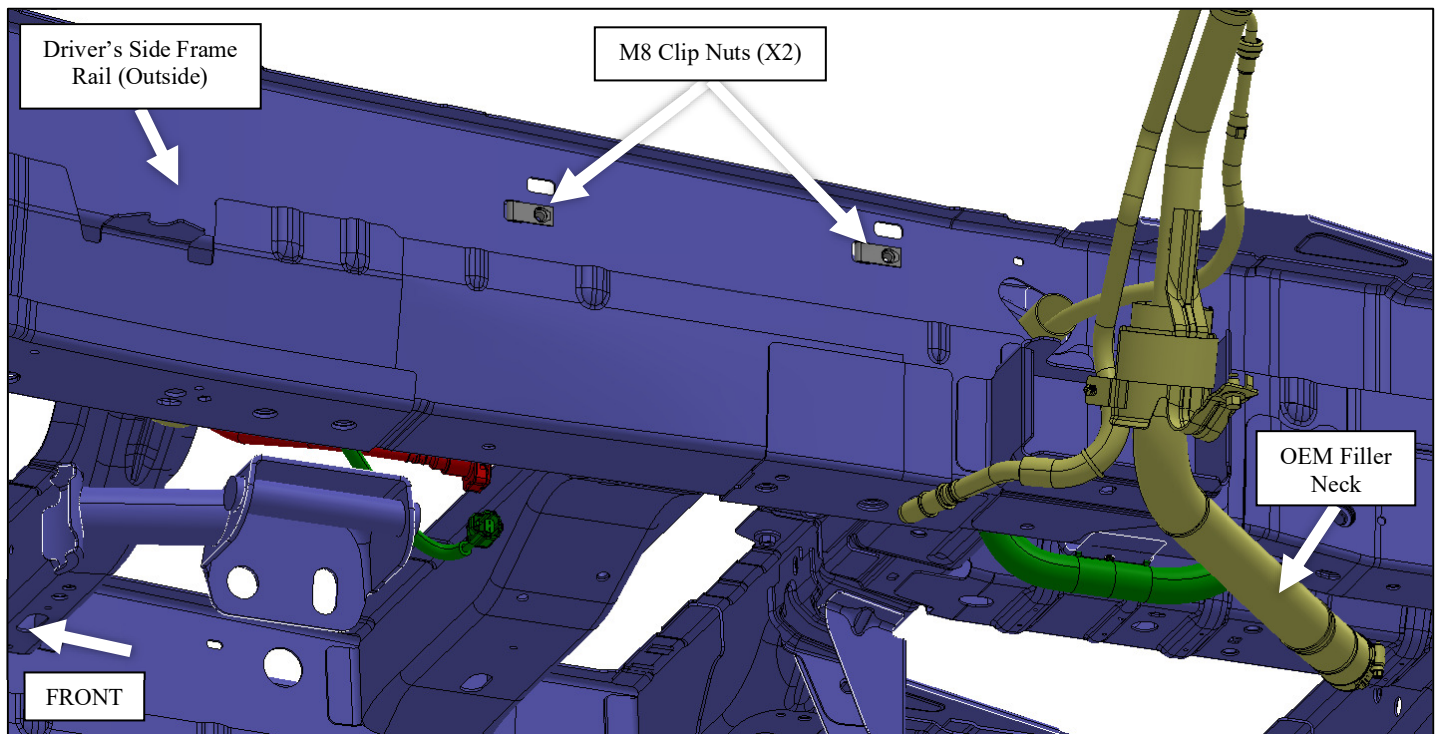

5. Fasten the preassembled canister assembly to the previously installed M8 clip nuts with (2) provided M8 bolts. Tighten the bolts to “hand-tight” until other hardware is installed to allow for adjustment.

a. For Passenger Van chassis:

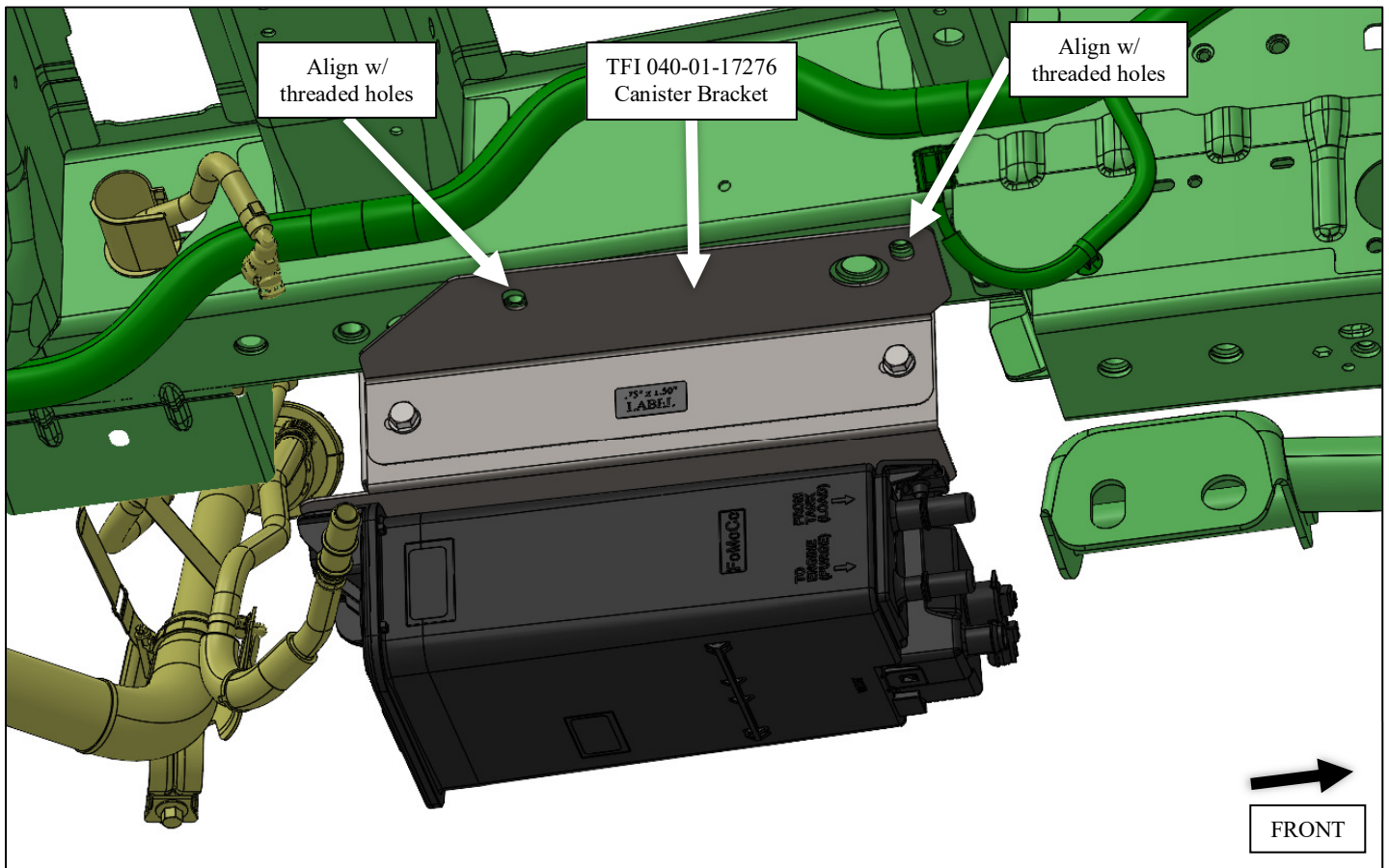
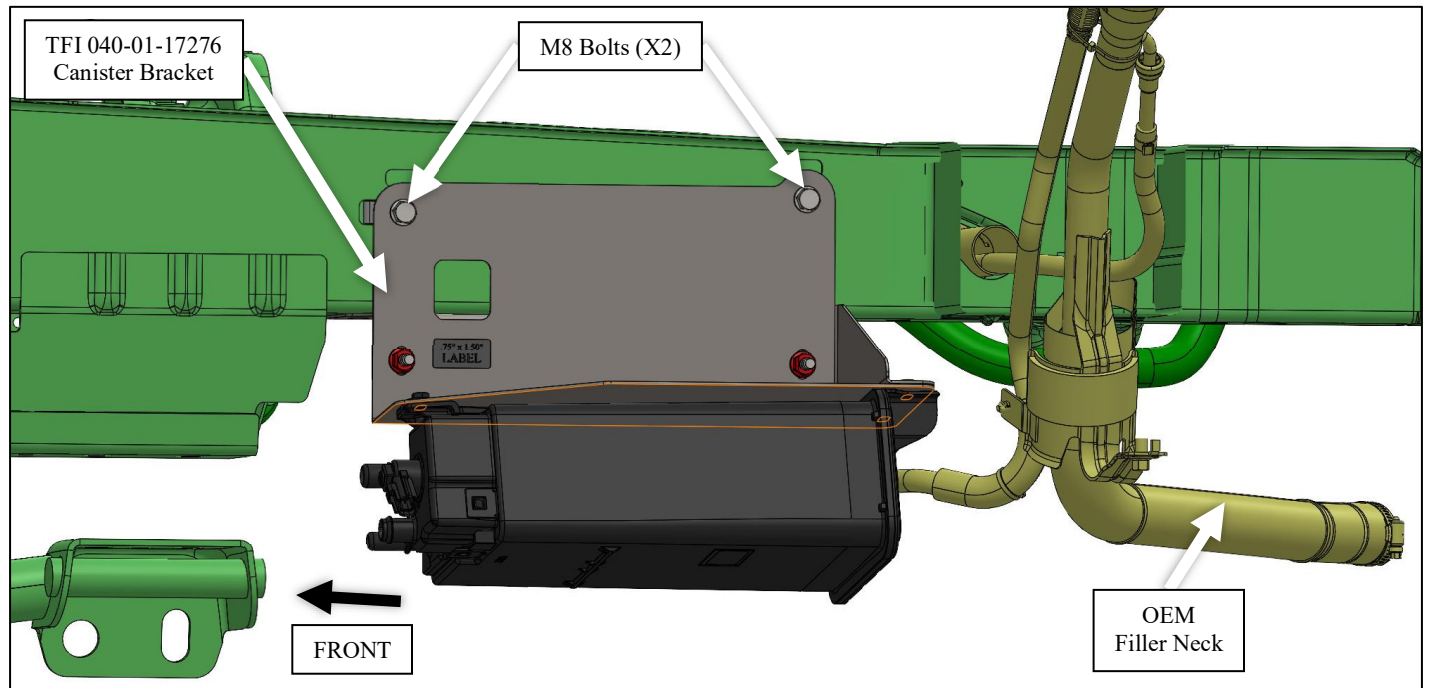

b. For Cutaway Van chassis:

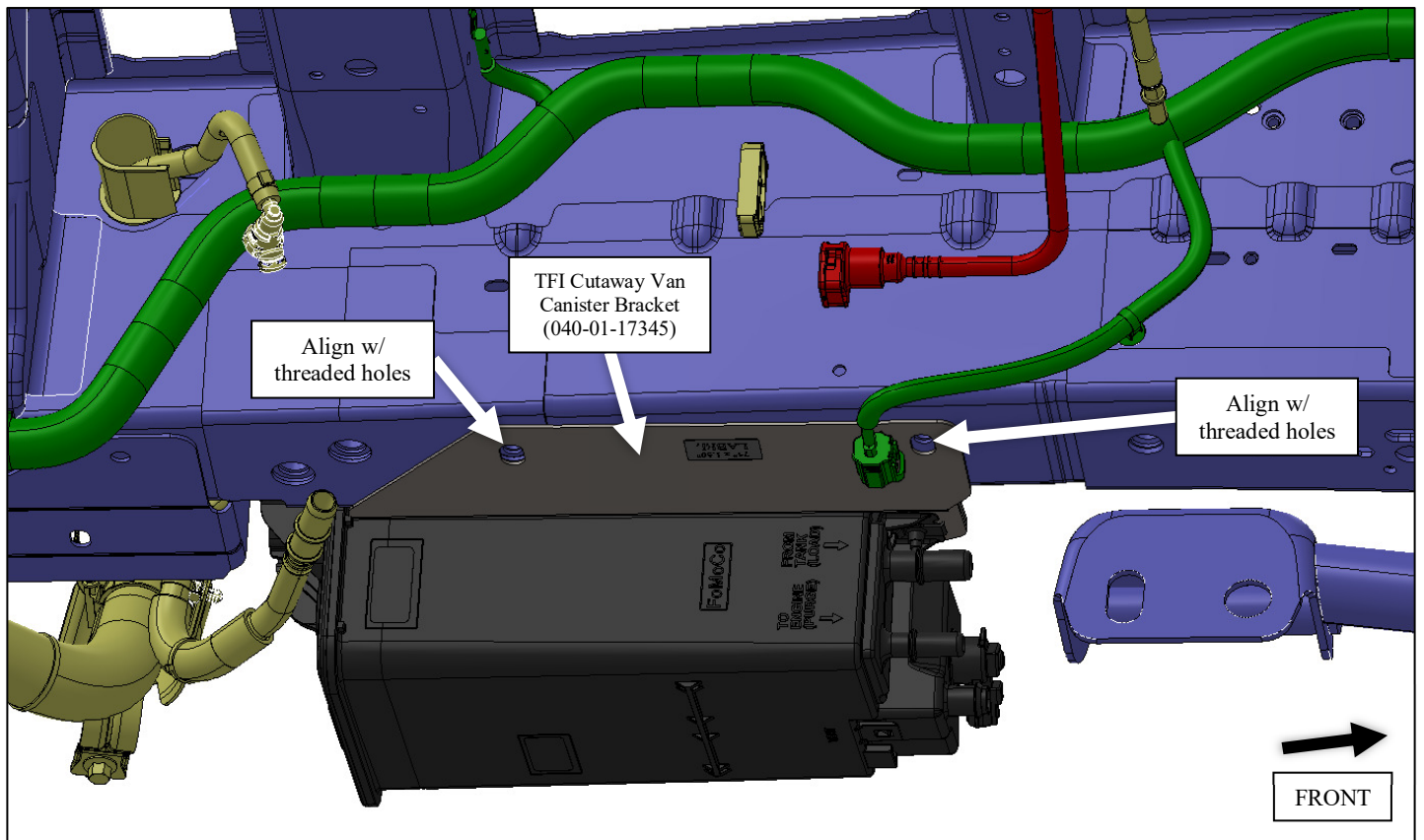
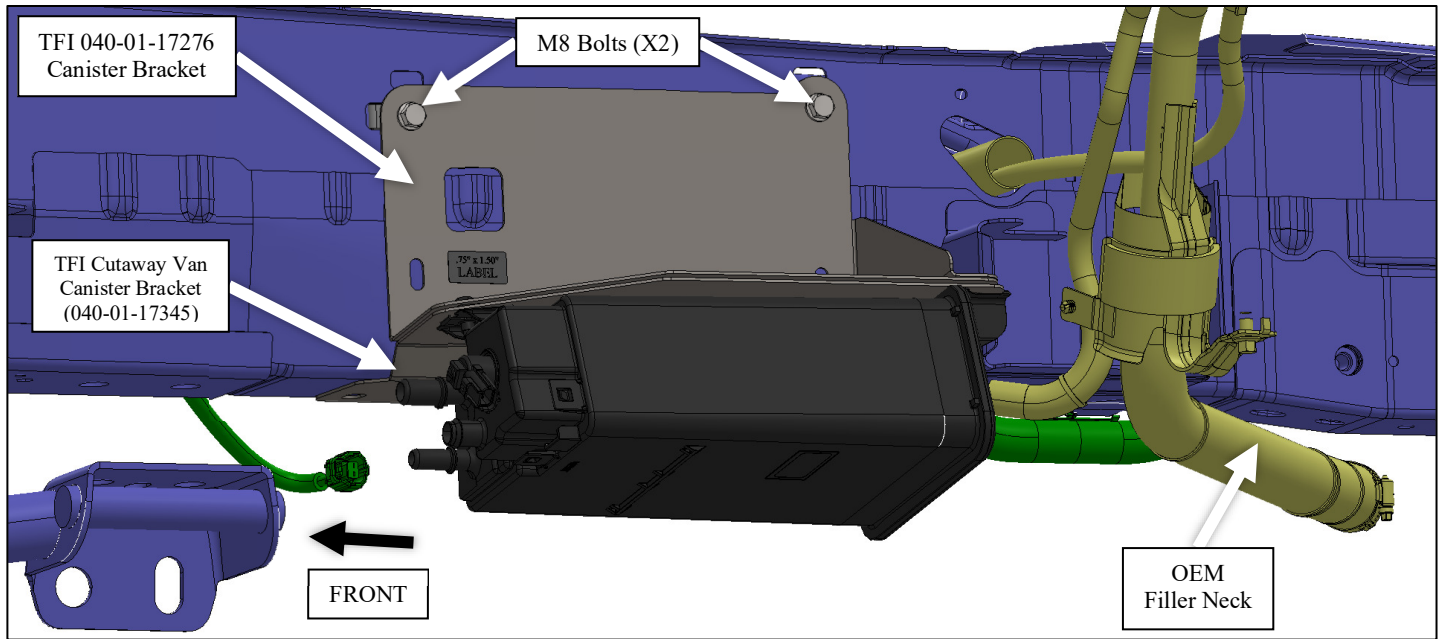

6. Install the Secondary OEM Canister using the OEM hardware. Tighten the two OEM M8 bolts to 20-25 ft-lbs.

a. For Passenger Van chassis:

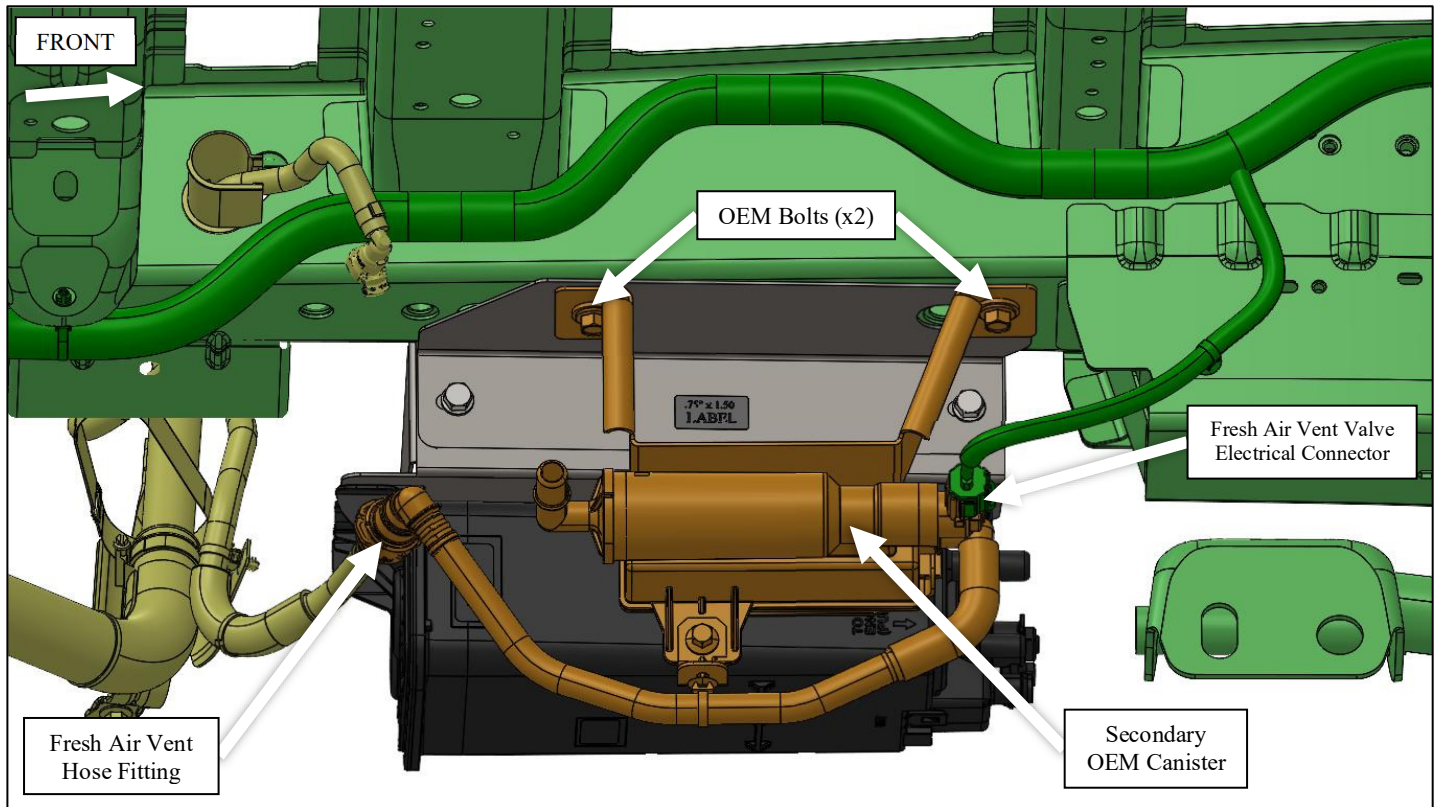

b. For Cutaway Van chassis:

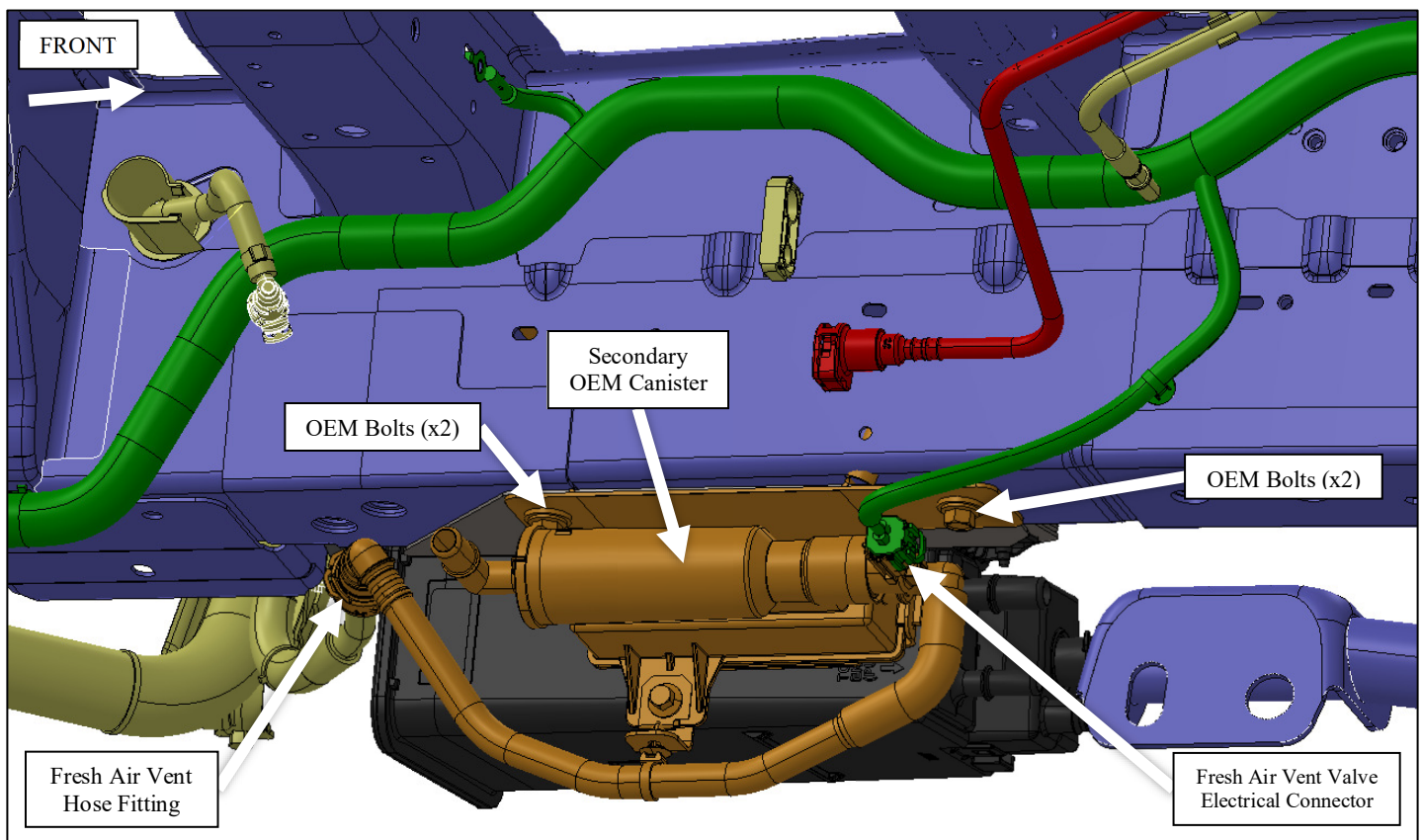

7. Fully tighten all canister bracket hardware.

a. For Passenger Van chassis:

- i. Tighten the M8 bolts holding the upper canister bracket to the outside of the frame rail to the M8 clip nuts. Torque to 15 ft-lbs.
- ii. Tighten the two bolts that connect the lower and upper canister brackets. Torque to 20-25 ft-lbs.

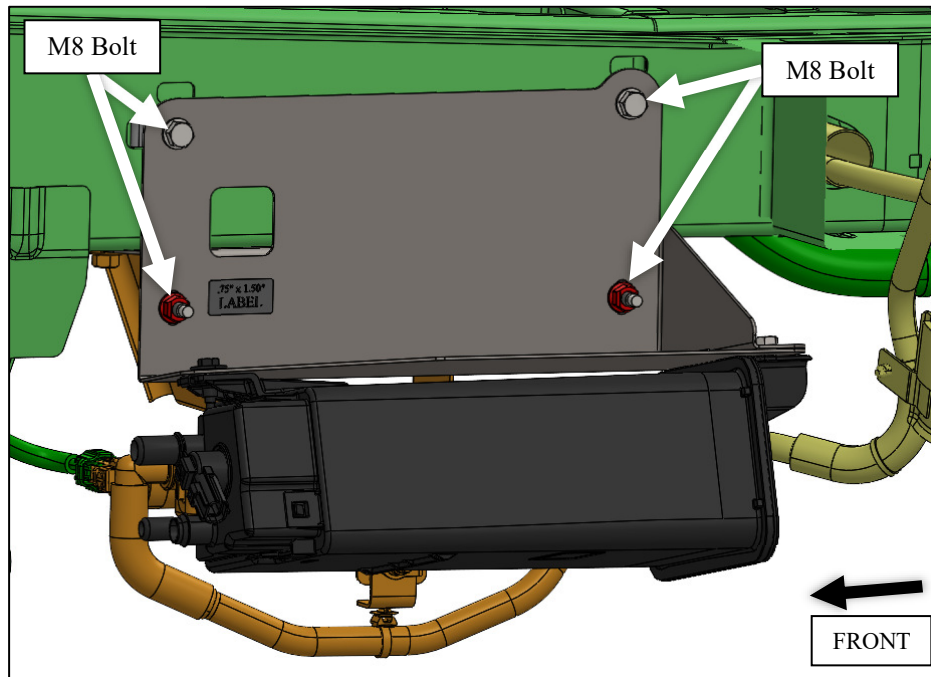

b. For Cutaway Van chassis:

- i. Tighten the M8 bolts holding the upper canister bracket to the outside of the frame rail to the M8 clip nuts. Torque to 15 ft-lbs.

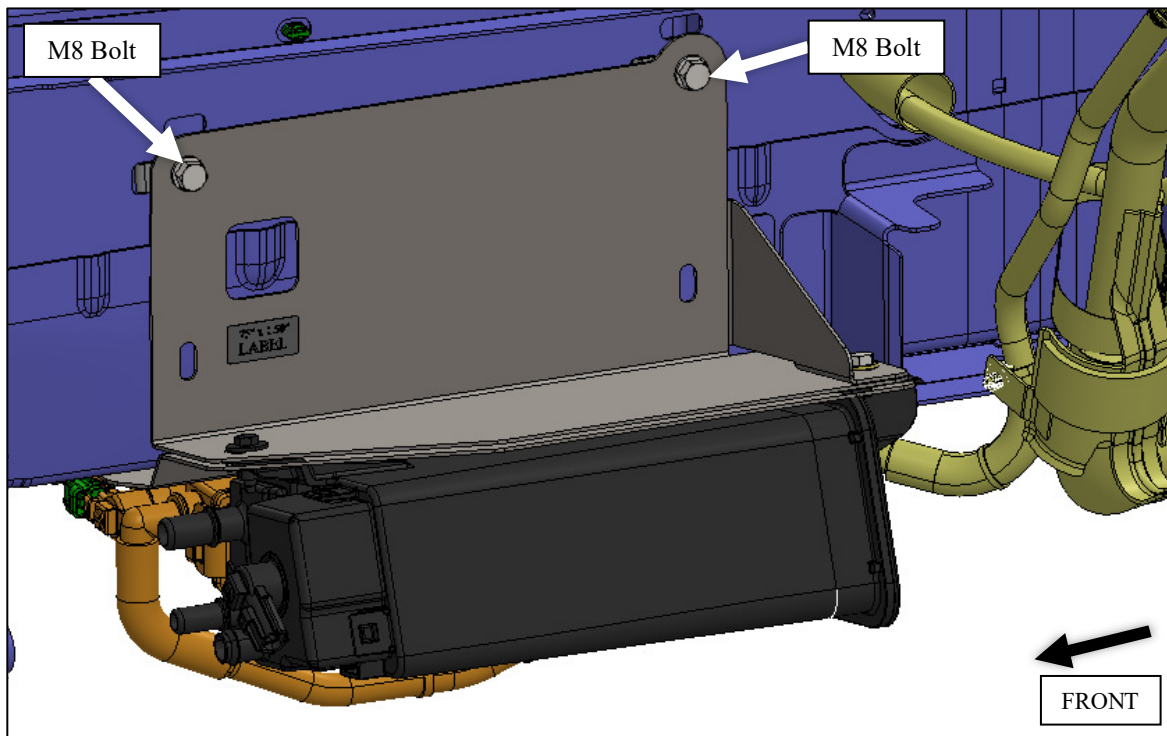

8. Rotate the Canister Vent Solenoid 1/8th-turn CW and pull to remove. Orient the solenoid such that it is pointed up, push in, then rotate 1/8<sup>th</sup>-turn CCW to secure. Make sure the solenoid is pointed up when in its final and locked position. Plug in the solenoid electrical connector.

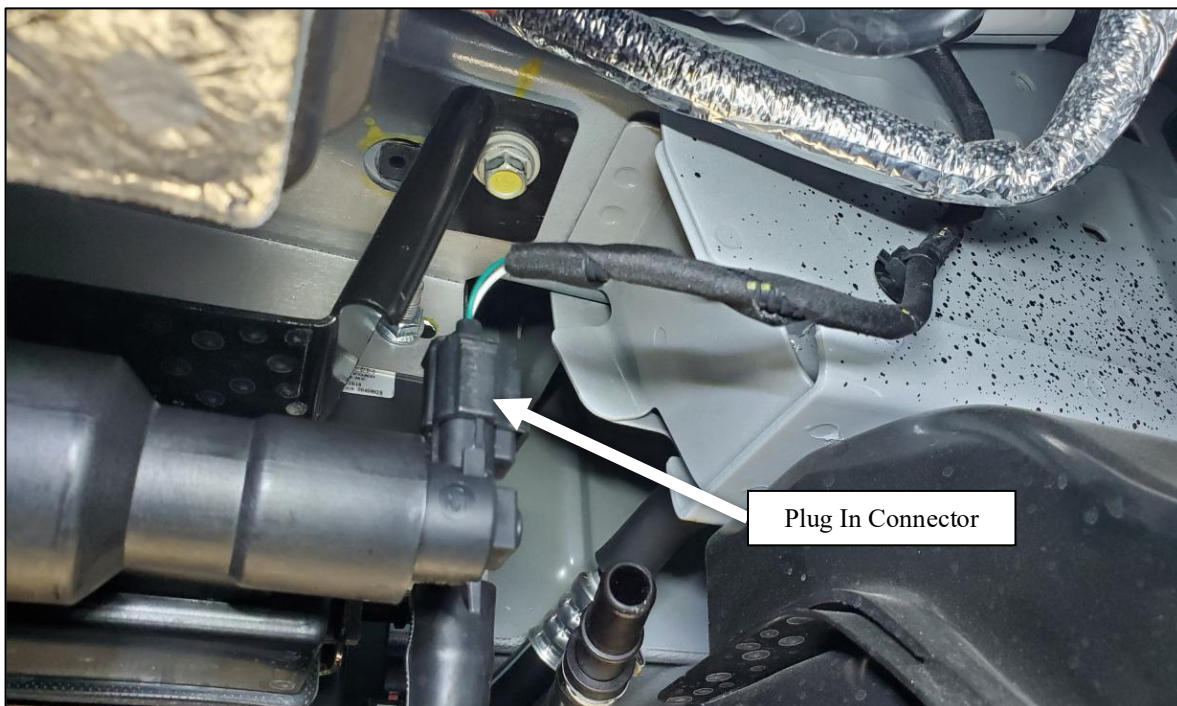

9. Remove the OEM bolt that secures the OEM vent line to the OEM filter assembly lower bracket. Turn the bolt around such that the head of the bolt is now on the outside of the bracket. Secure the bolt with the provided nut.

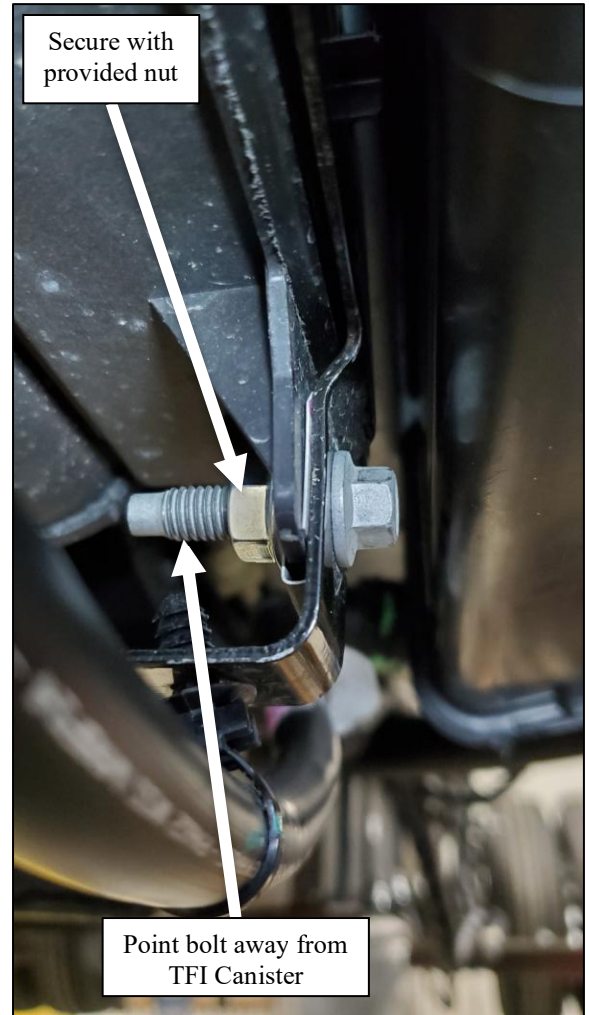

## **SECTION 3: RELOCATING THE OEM WIRE HARNESS** **CUTAWAY/CAB CHASSIS VANS ONLY**

**NOTE: If you have a Passenger Van or Cargo Van chassis, please skip this section and continue to tank installation.**

1. Remove clips that secure the OEM wire harness to the chassis in the areas shown below. The wire harness must be moved to avoid contact with the replacement fuel tank.
2. Move this section of the wire harness below the Filler Neck Vent Line and under the frame rail as shown below.

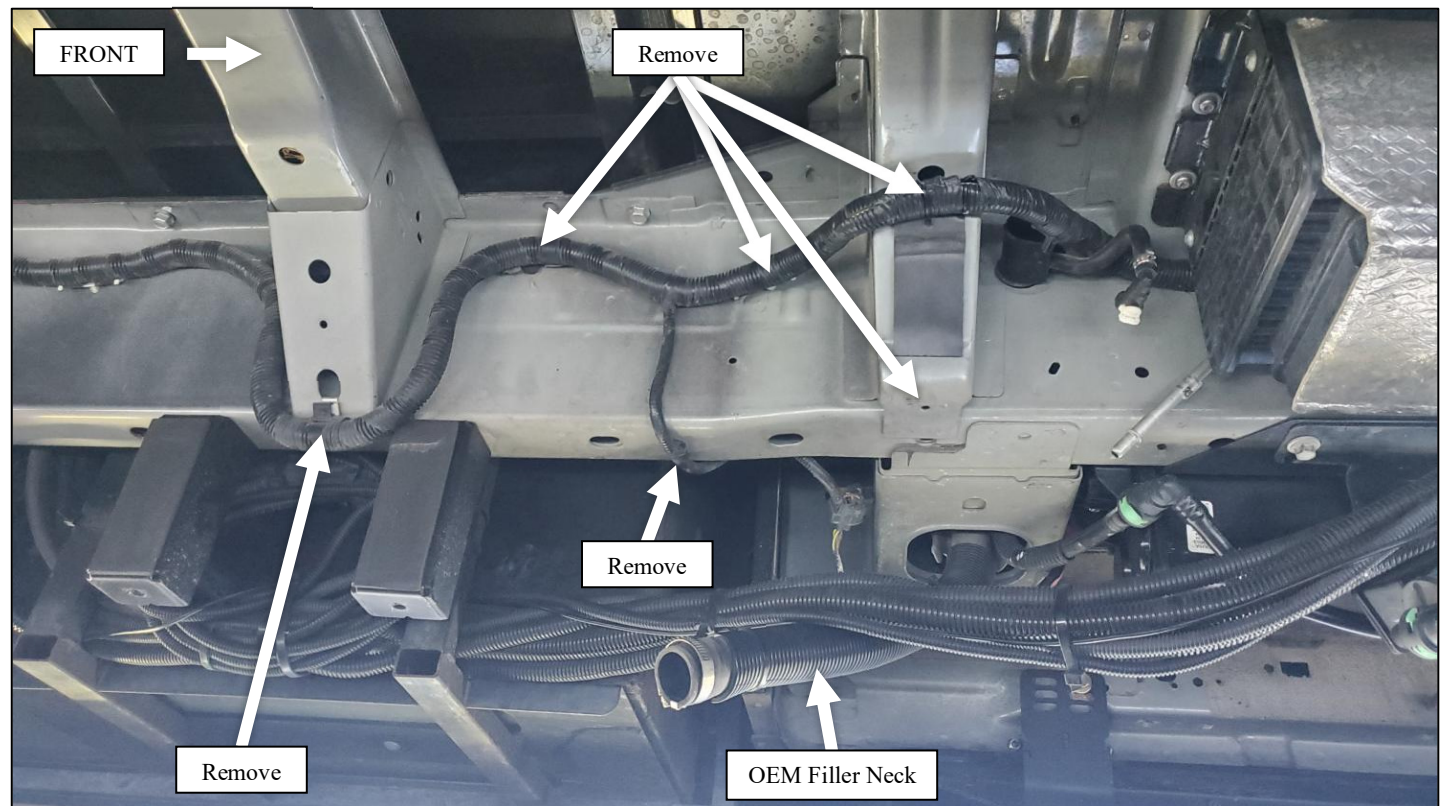
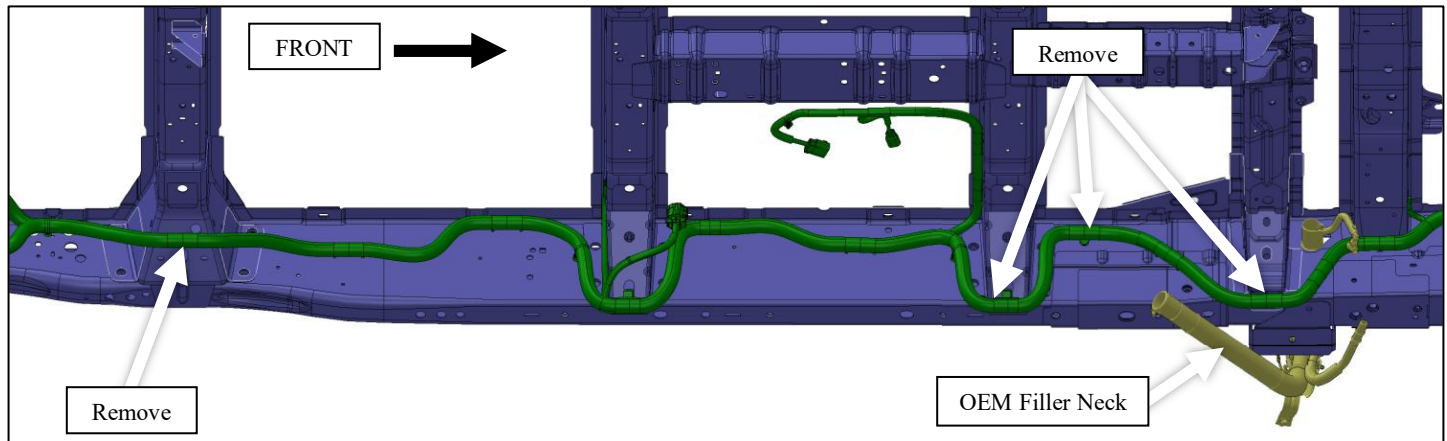

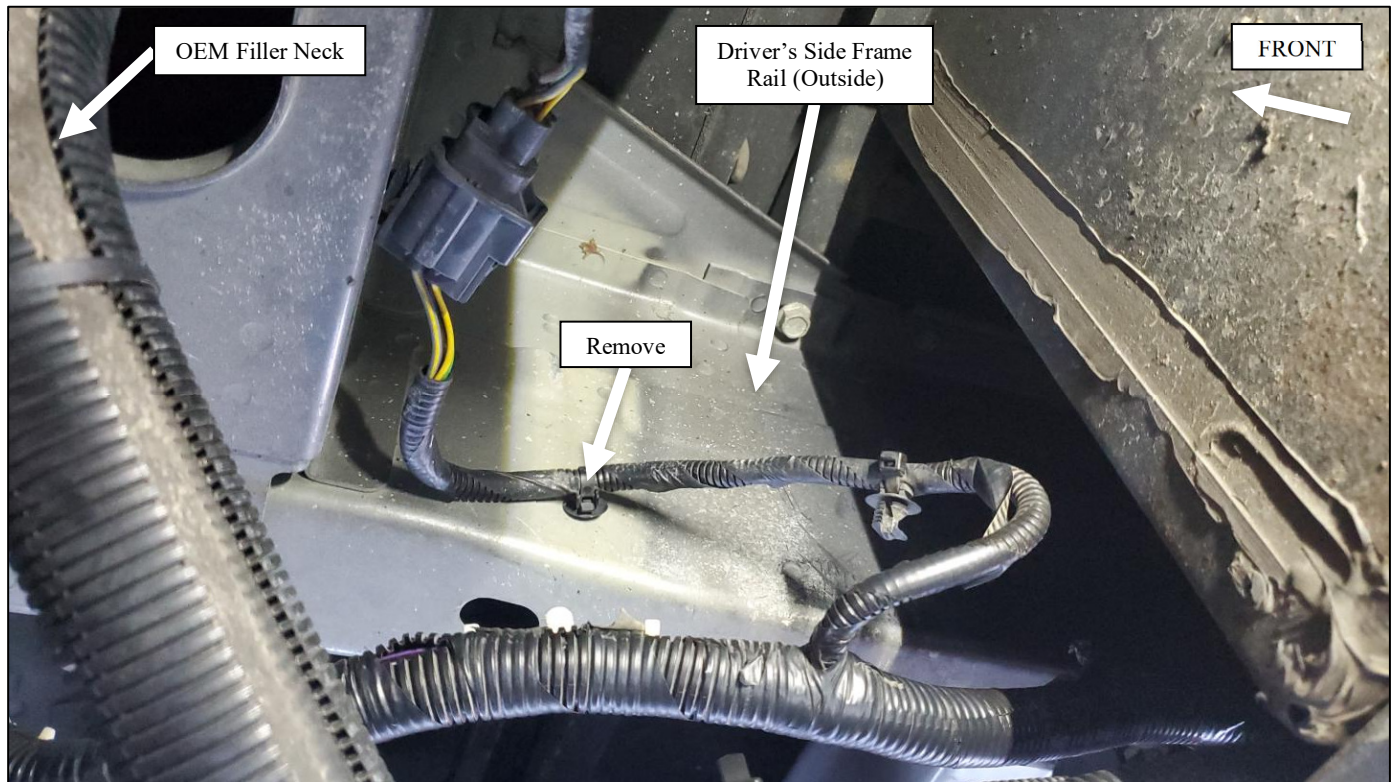
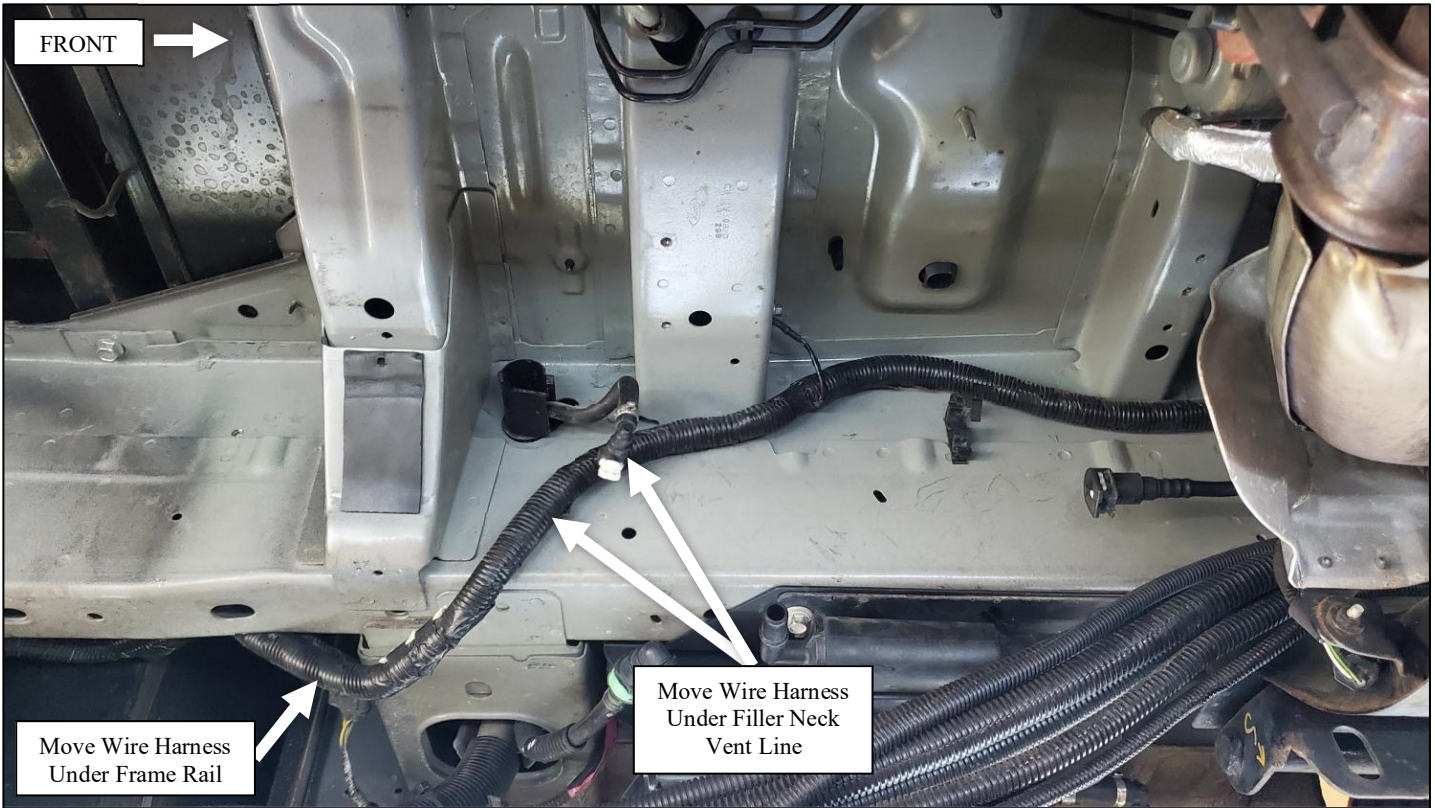

3. Remove the wire harness clip at the rear cross member as shown below.

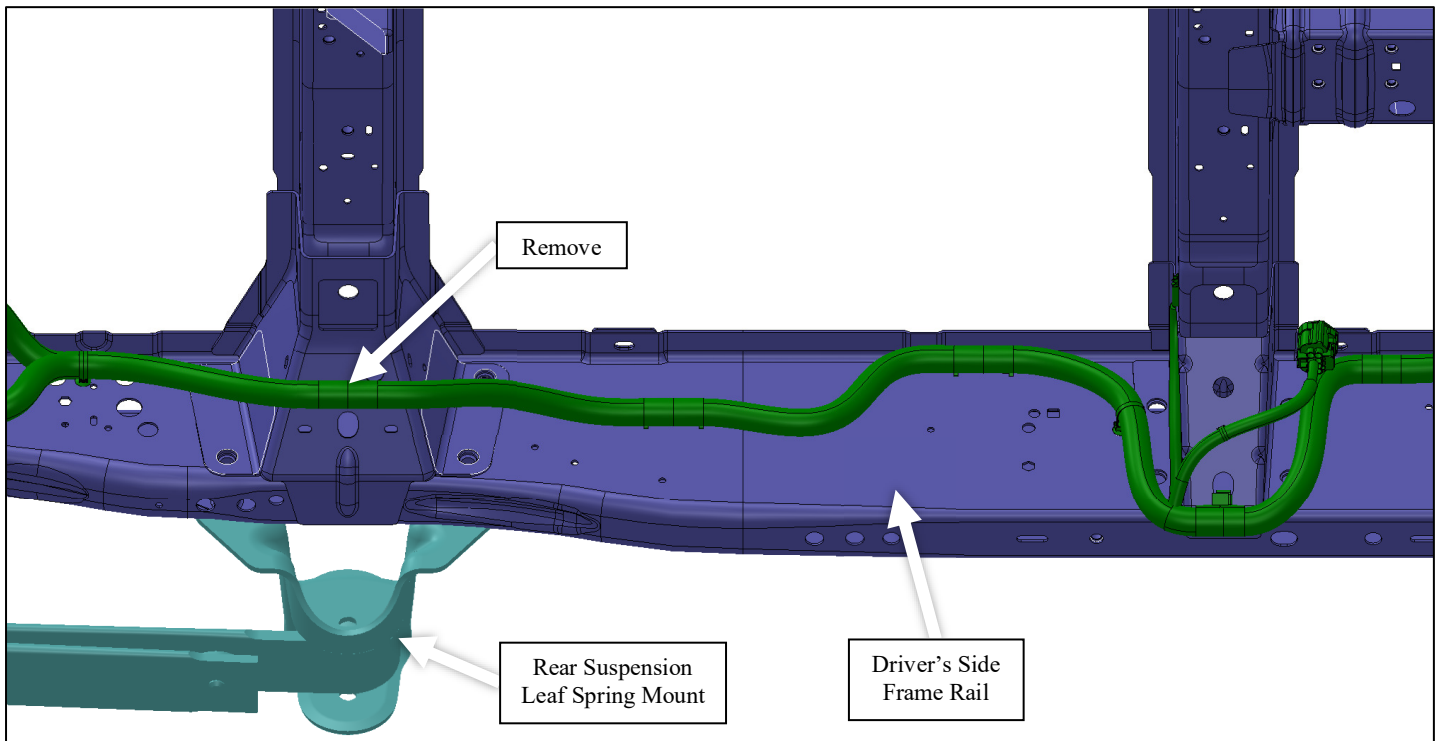

4. Keep the wire harness out of the way during fuel tank installation to avoid pinching and/or damaging the wires. The wire harness will be secured after the tank and emissions components are installed.

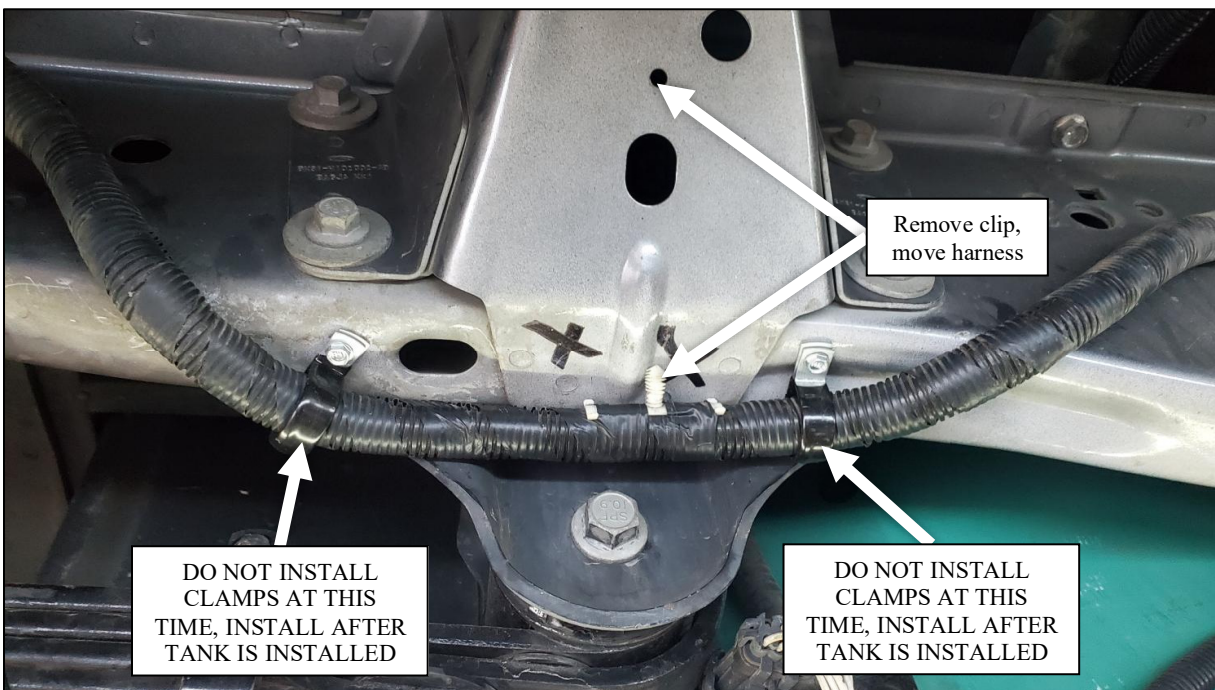

## **SECTION 4: PREPARING THE REPLACEMENT TANK**

1. Remove the sending unit cover plate on the replacement tank by loosening the six bolts on top of the sending unit ring. Discard the cover plate.
2. Check that the green sending unit o-ring is installed properly and rests in the groove on the sending unit mount ring.

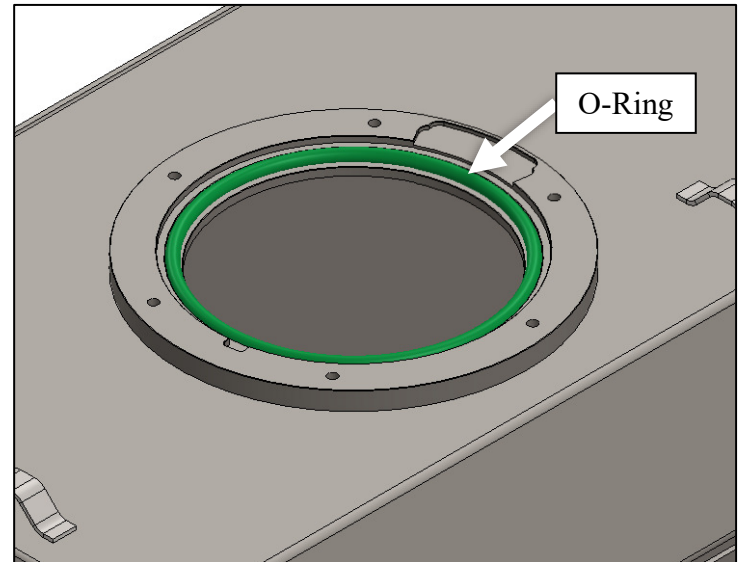
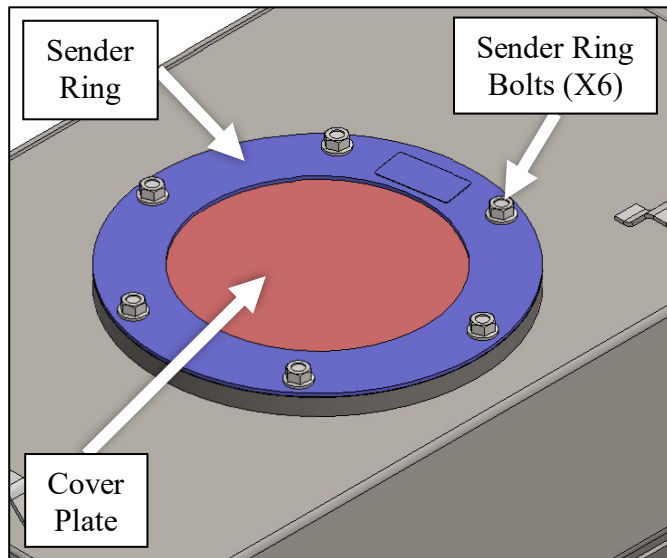

3. Install the OEM sending unit into the replacement tank and align the locating tab in the sending unit mount ring. Carefully guide the float wire into the tank and make sure that it does not bend or interfere with other parts of the sending unit.
4. While holding the sending unit top down against the mount ring, reinstall the sending unit ring and fasten the six bolts from Step 1.

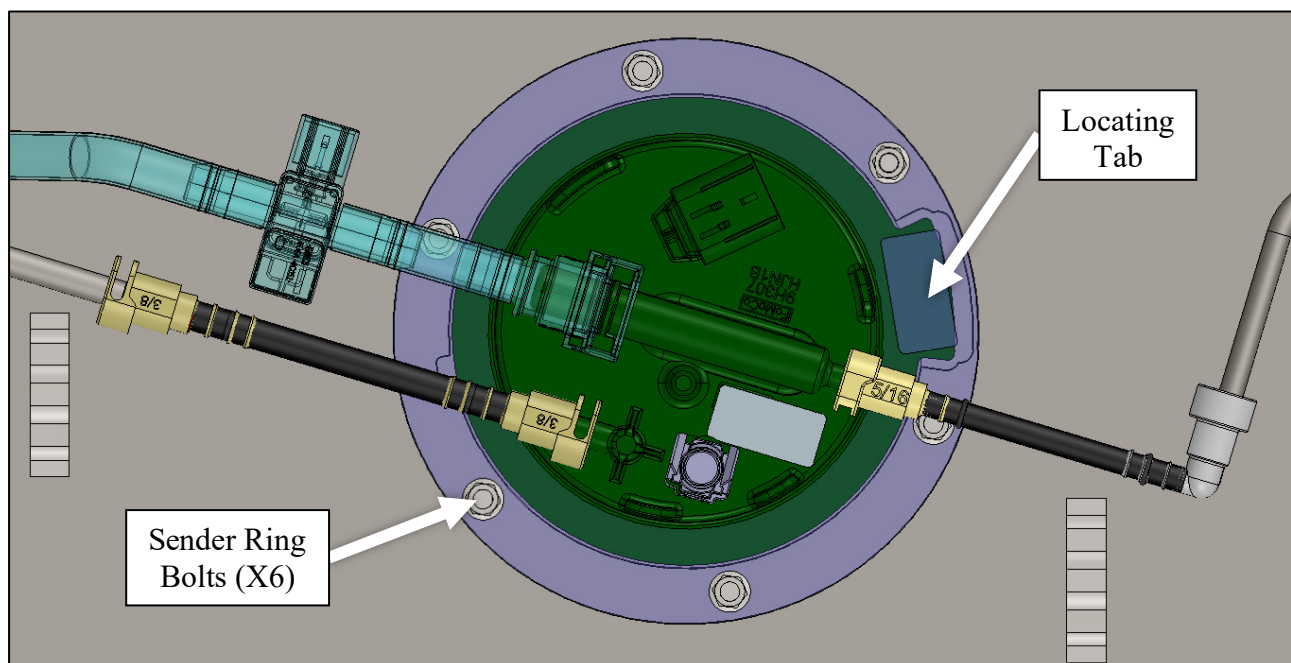

5. Remove the cap on the rear steel tube and install the rear vent line adapter.
6. Remove the cap on the front steel fuel tube and install the fuel line adapter.

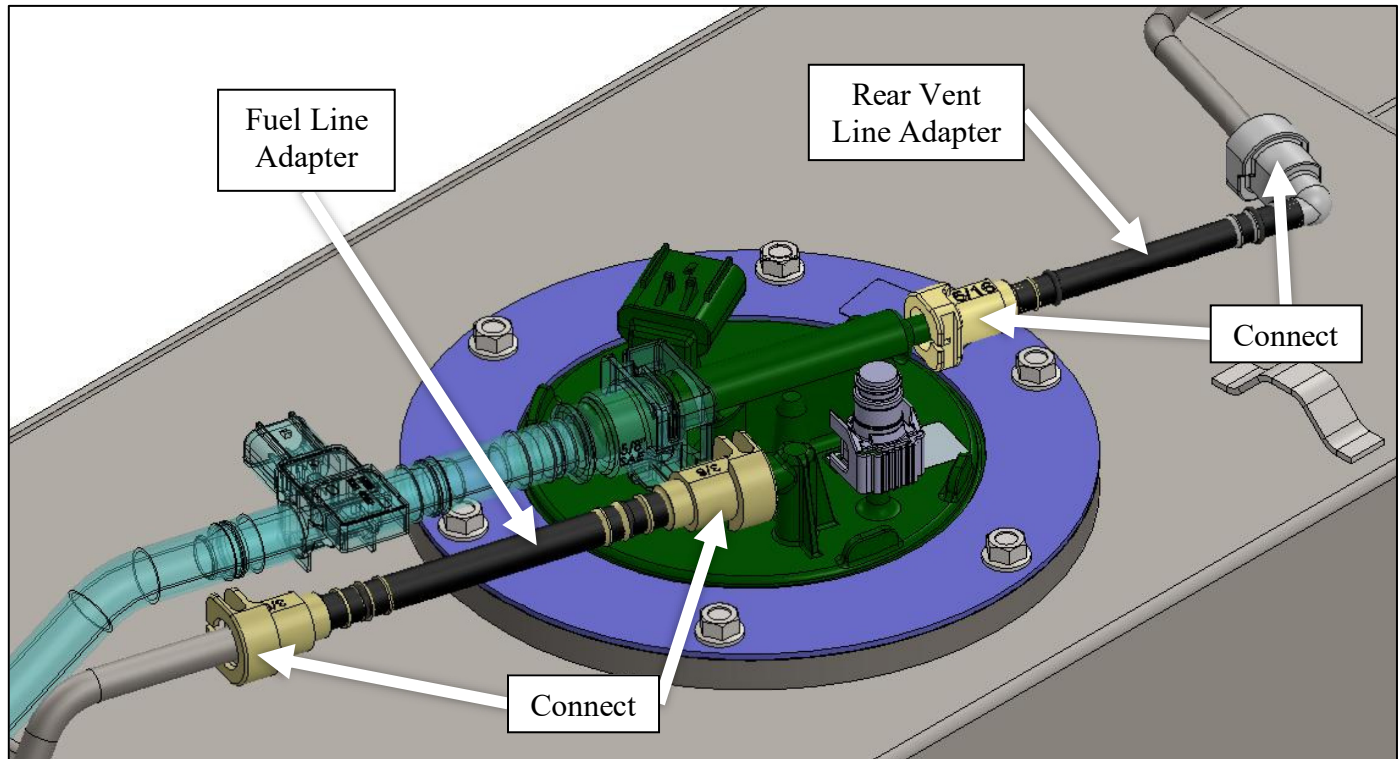

7. Remove the nuts securing the steel TFI fuel line to the tank so that the adapters can be installed. Only remove the top nut on each weld stud and do not completely remove the TFI fuel line.
8. Locate the OEM tank vent line (reuse from OEM tank) and install it onto the replacement tank. Plug in the quick-connect fitting on the OEM tank vent line to the sending unit as shown. Plug in the quick-connect fitting on the OEM tank vent line to the front roll-over valve on the replacement tank.
9. Using the provided p-clamps, secure the OEM tank vent line to the replacement tank. Some adjustment to the OEM tank vent line and TFI fuel supply line will be required. Make sure that neither line is contacting the tank.
10. Secure the OEM tank vent line and TFI fuel supply line with the nuts removed in step 7.

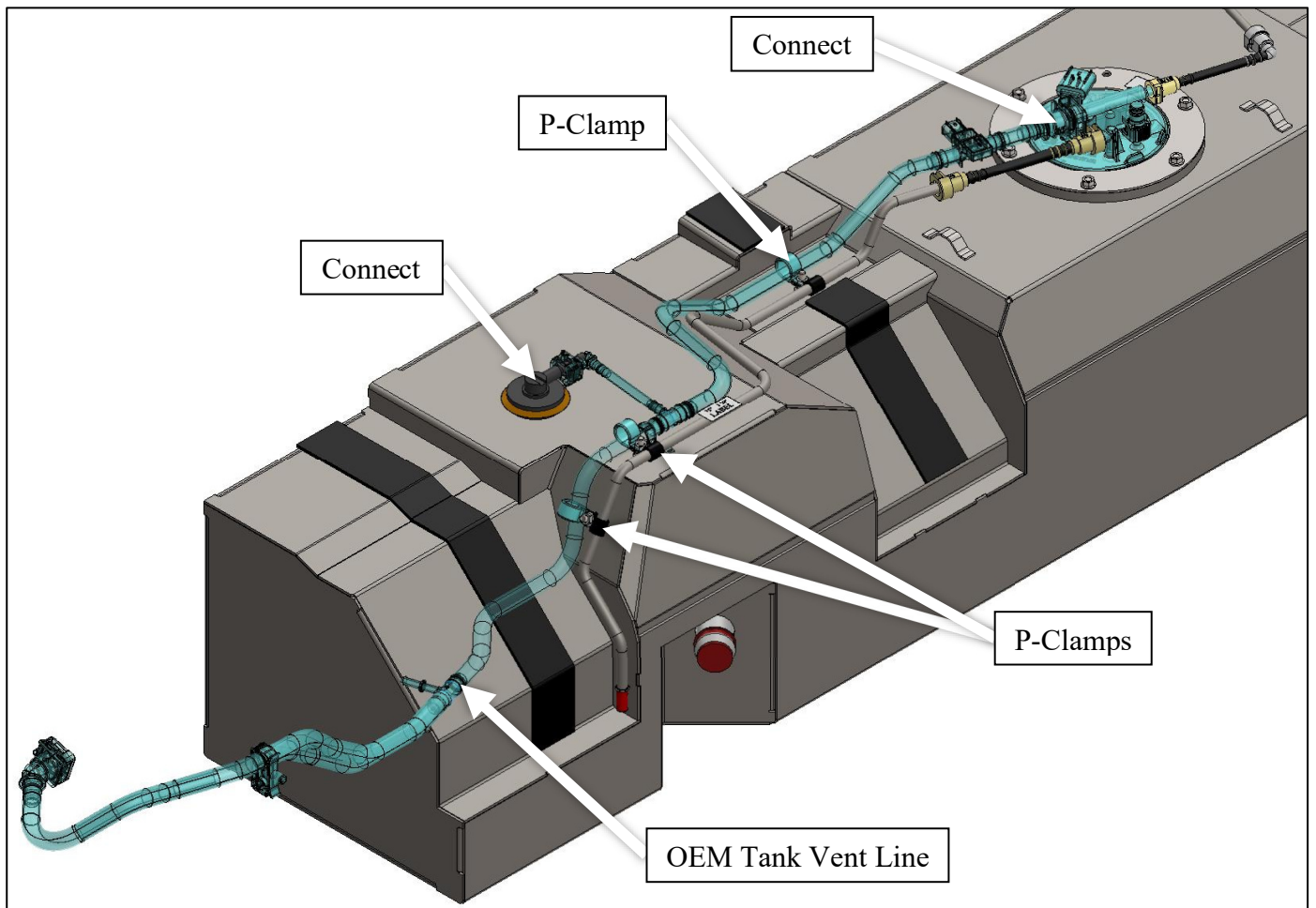
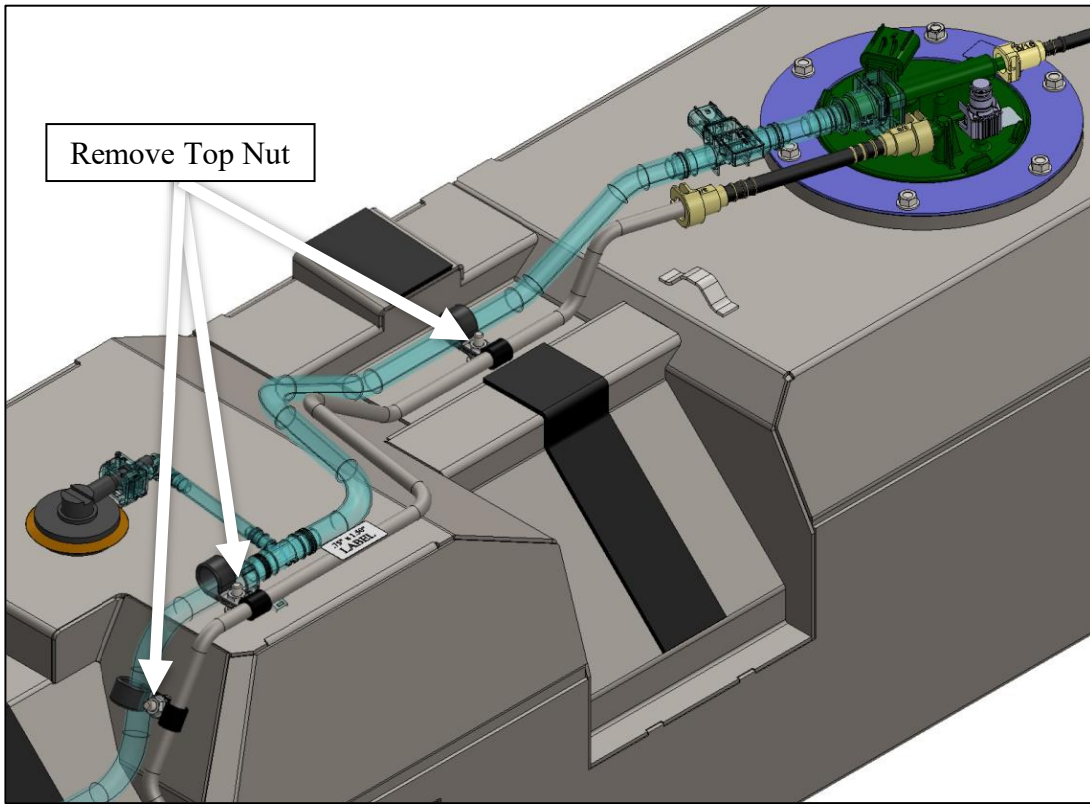

11. Using a multimeter, attach the wire clamps to the two pins on the left of the sending unit plug. Set the multimeter to the resistance setting. The sending unit should read 180-184 Ohms when installed in the empty tank.

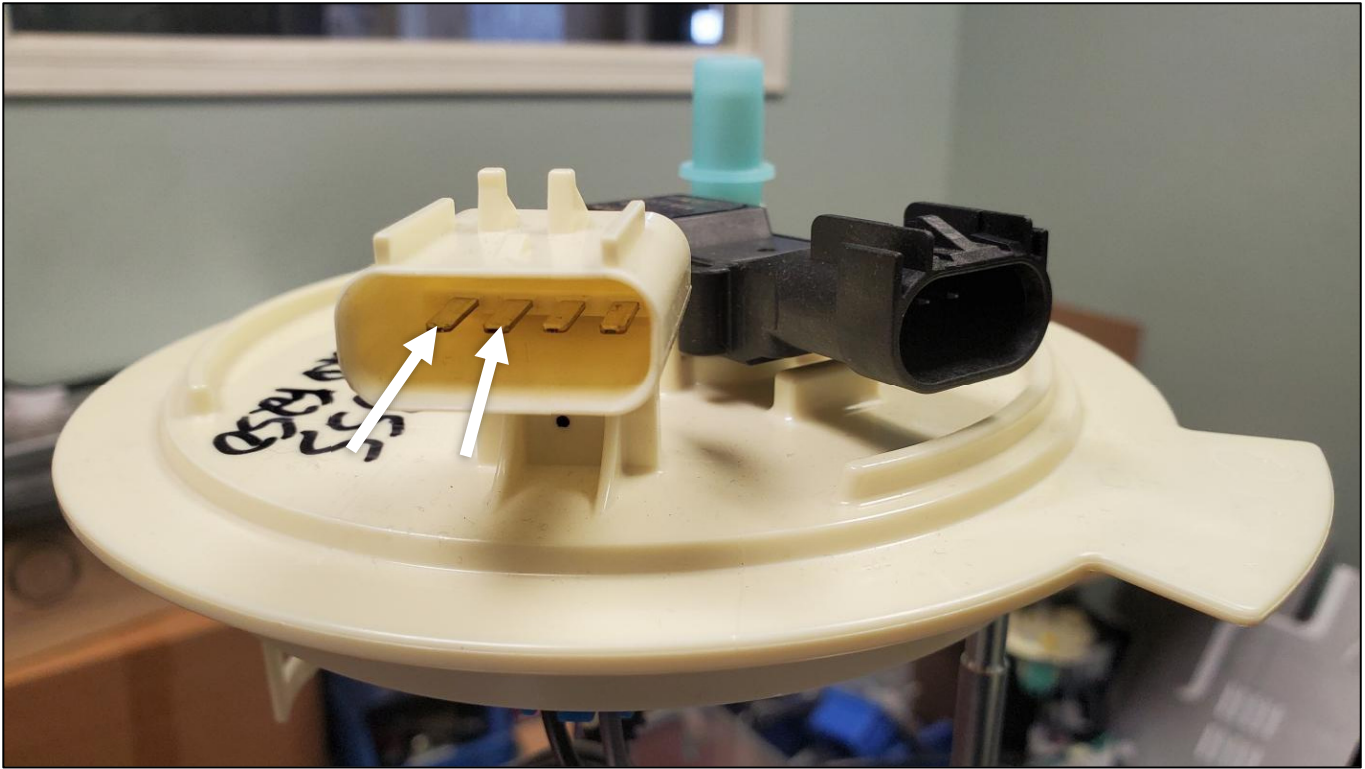

## **SECTION 5: PRESSURE TESTING THE REPLACEMENT TANK**

1. Seal the tank vent line at the front fitting, or if no plug is available, seal the system at the 5/8" port on top of the sending unit.
2. Cut a small slit in the red cap of the fill neck tube to insert an air nozzle. Alternatively, an air supply with a quick-connect fitting can be connected to the brass fill neck vent port (5/16" J2044).
3. Pressurize the tank to 1-3 psi MAX and use a soapy water solution to thoroughly check for leaks around all valves, the sending unit, sealing surfaces, and connection points. If any leaks are present, reseal the affected area and retest the system. If no leaks are found, remove all plugs, seals, and/or caps. Allow the air pressure to escape the tank.

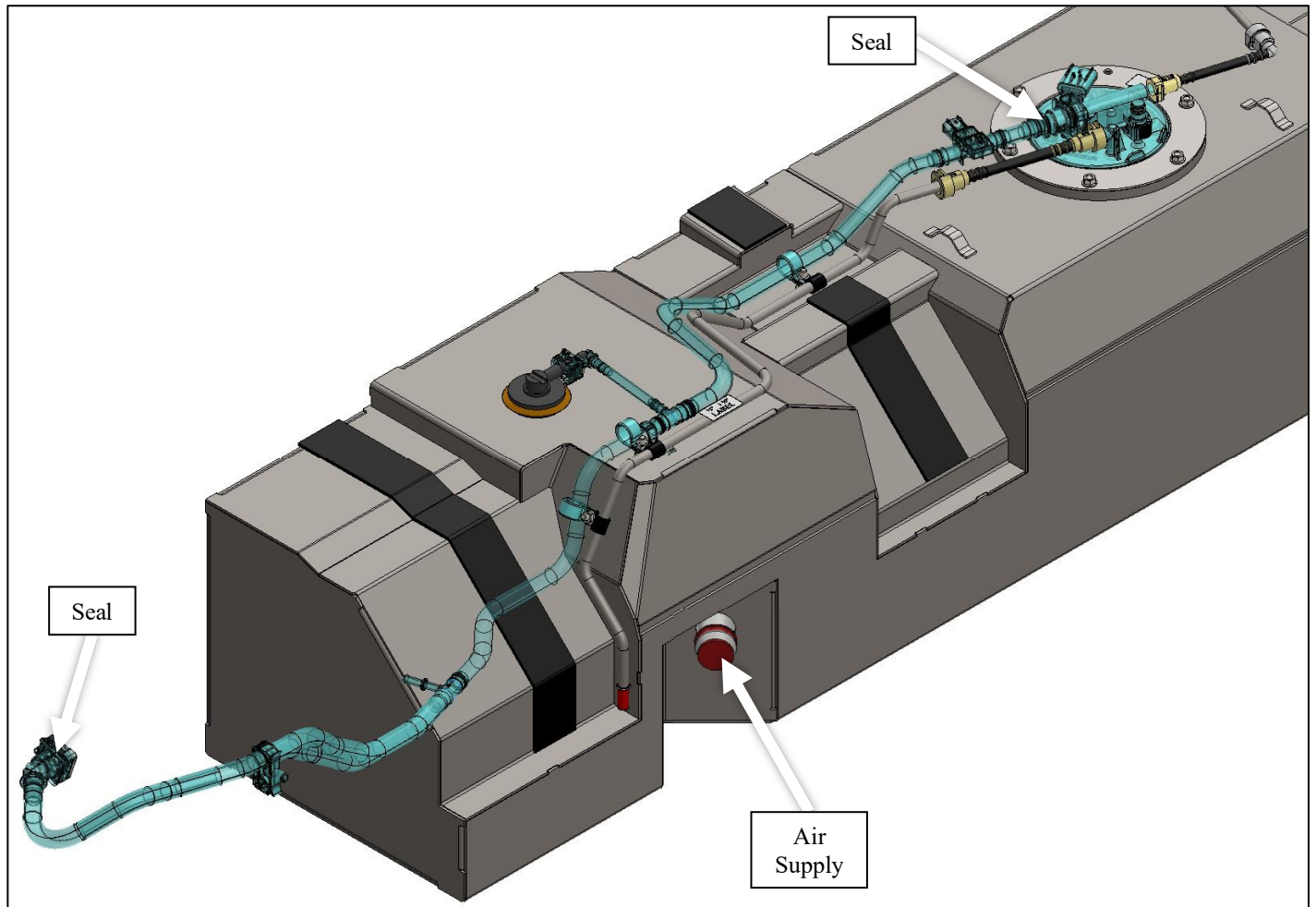

## SECTION 6: INSTALLING THE REPLACEMENT TANK

10. Connect the fuel pump control module electrical connector.
11. Install the section of provided foam on the front crossmember, next to the fill neck vent line.



12. Install the three TFI hanger straps on the driver's side frame rail with the OEM. Do not fully tighten the bolts to the frame at this time, leave about 1 inch of clearance between the top of the strap hanger bracket and the bottom of the frame rail.

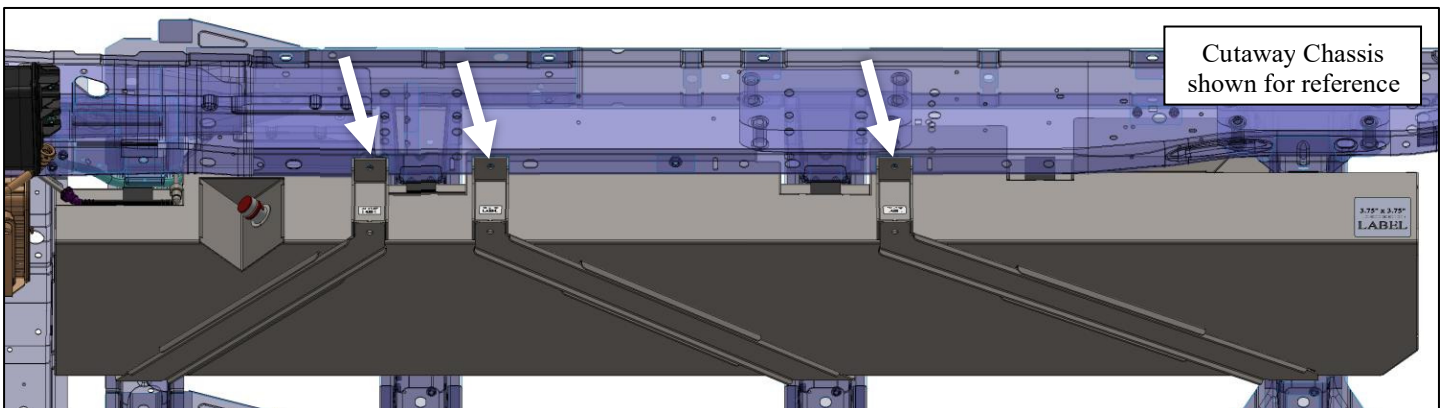

13. Place the replacement tank on a hydraulic or pneumatic lift and align with the frame cross members.
14. Raise the tank until it is roughly 12-18 inches from the final mounting location.
  - a. Maneuver the OEM tank vent line between the frame rail and OEM emissions canister.
15. Connect the sending unit and pressure sensor electrical connectors.

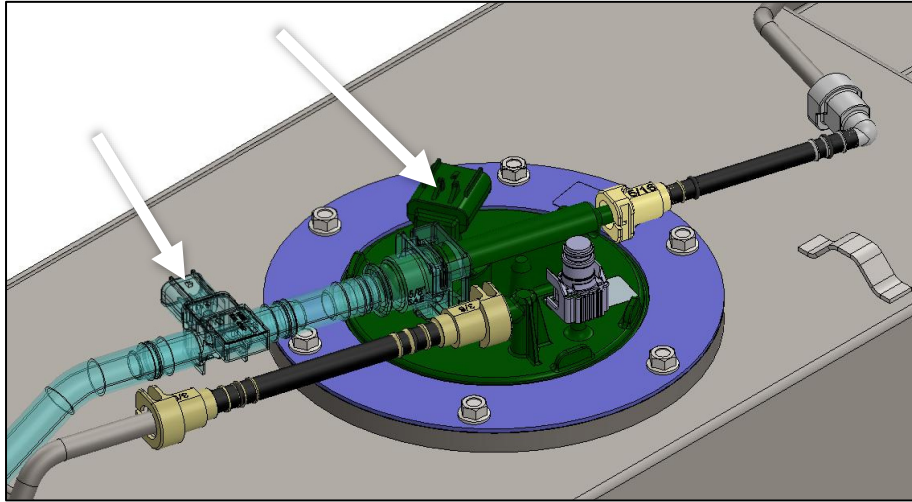

16. Raise the tank slowly, making sure that no part of the wiring harness or fuel/vapor hoses are pinched or kinked. Feed the OEM Tank Vent Line between the OEM Emissions Canister and the driver's side frame rail.
17. Install the TFI tank straps as shown. Fasten the TFI tank straps to the TFI hanger straps using the supplied hardware. Fasten the TFI tank straps to the frame cross members using the OEM hardware. Tighten all hardware so that it is hand-tight, then fully tighten hardware and while making sure that the straps are located properly in the strap guides.
  - a. 040-01-17277 Front Strap
  - b. 040-01-17278 Mid Strap
  - c. 040-01-17279 Rear Strap
  - d. Torque hardware per IS-484 and remove the tank lift.

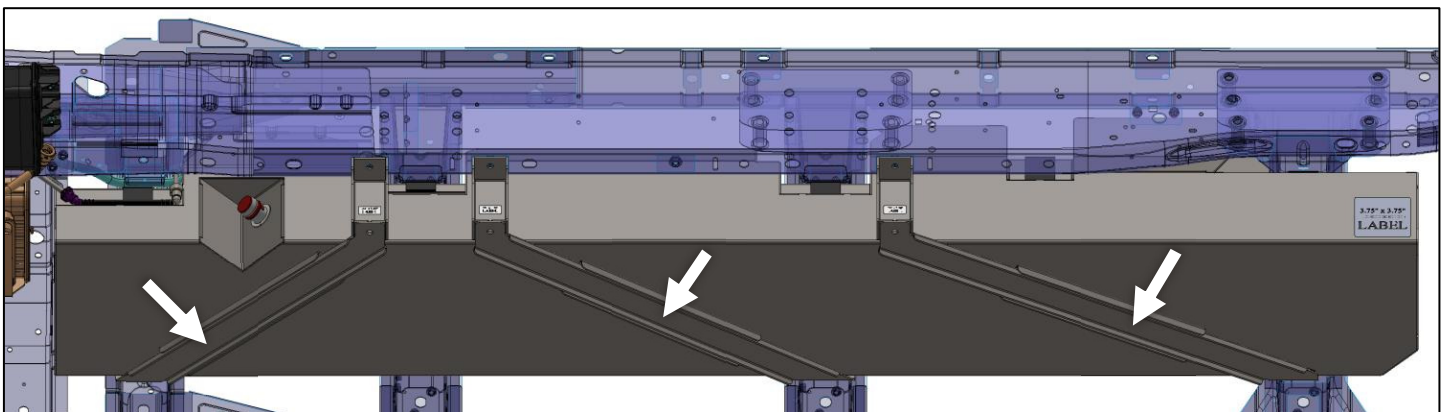

18. Install the rubber hose from the OEM fill neck onto the tank filler neck and secure with the OEM gear clamp. Torque to 30 in-lbs using a 7mm socket or wrench.



19. Insert the OEM Tank Vent Line into the plastic clip located between the OEM emissions canister and the driver's side frame rail. Press the hose into the top slot of the clip.
20. Remove the red caps and install the TFI Front Steel Fuel Line 050-01-17291 into the bottom slot of the plastic clip, as shown. Secure both tubes by closing the plastic clip.
21. Connect the OEM Filler Neck Vent to the t-fitting on the OEM fuel tank vent line and lock the white clip.

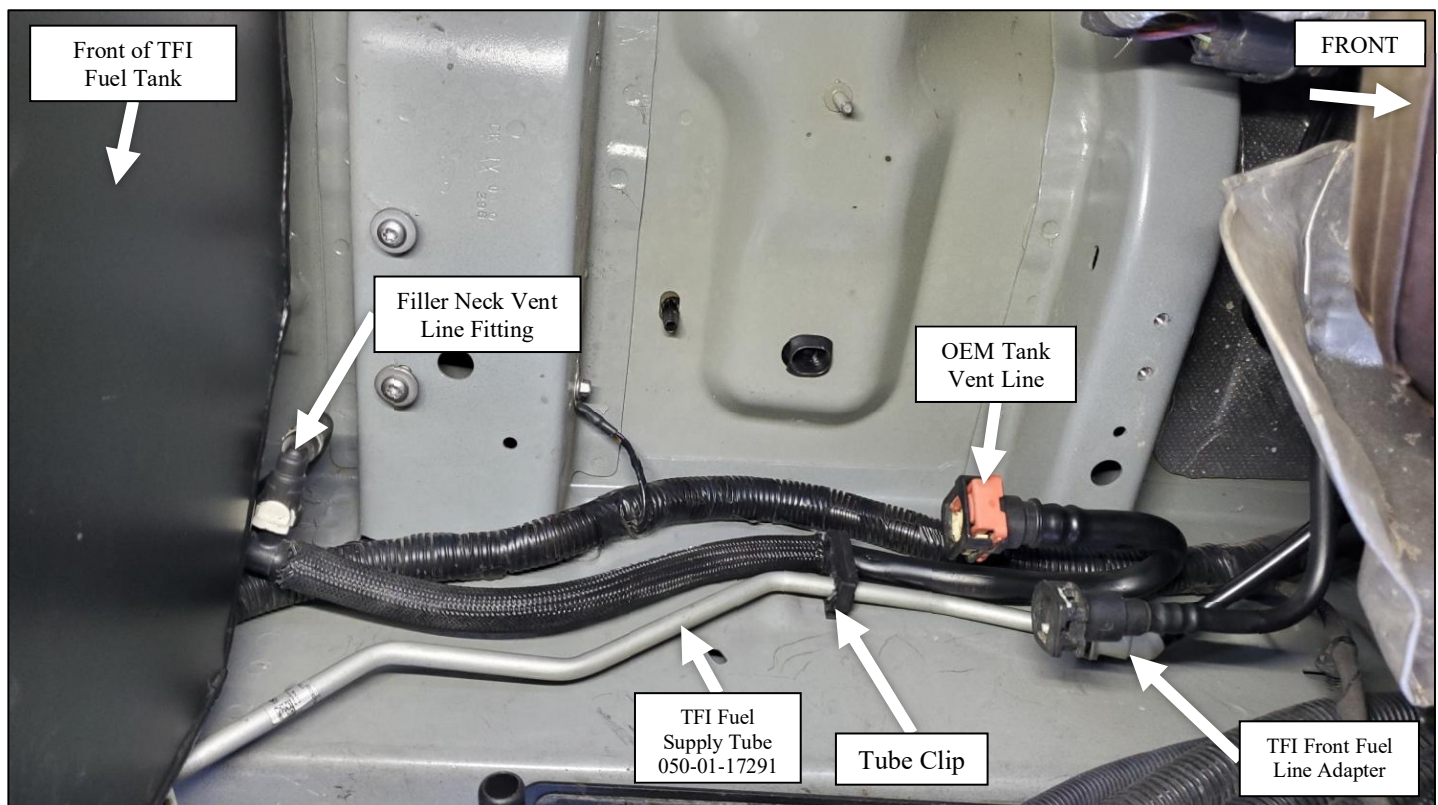

22. Install the TFI Mid Fuel Line Adapter that connects the steel fuel line on the tank to the TFI Front Steel Fuel Line (050-01-17291).



23. Install the TFI Front Fuel Line Adapter to connect the TFI Front Steel Fuel Line (050-01-17291) to the OEM fuel supply tube.

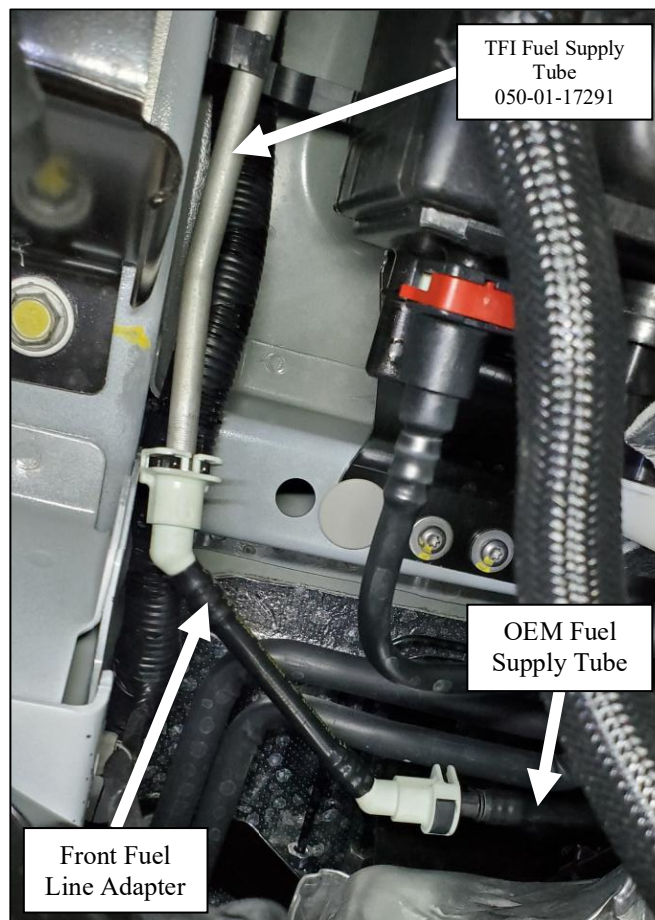

## SECTION 7: INSTALLING THE OEM EMISSIONS CANISTER AND TFI VAPOR LINES

1. Install the OEM Emissions Canister in the original location. Secure the canister with the OEM hardware that was removed earlier in the installation.
  - a. While installing the canister, connect the OEM Tank Vent Line to the 5/8in quick-connect port, and the OEM Canister Purge Line to the 1/2in quick-connect port.

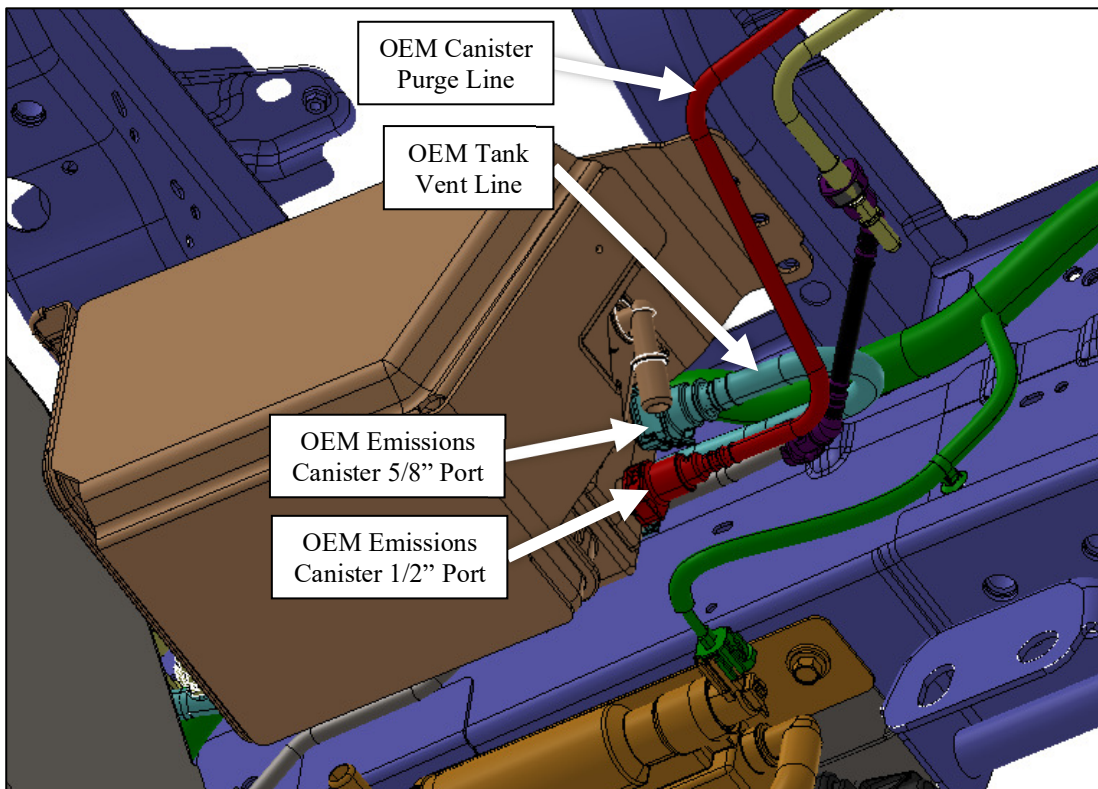
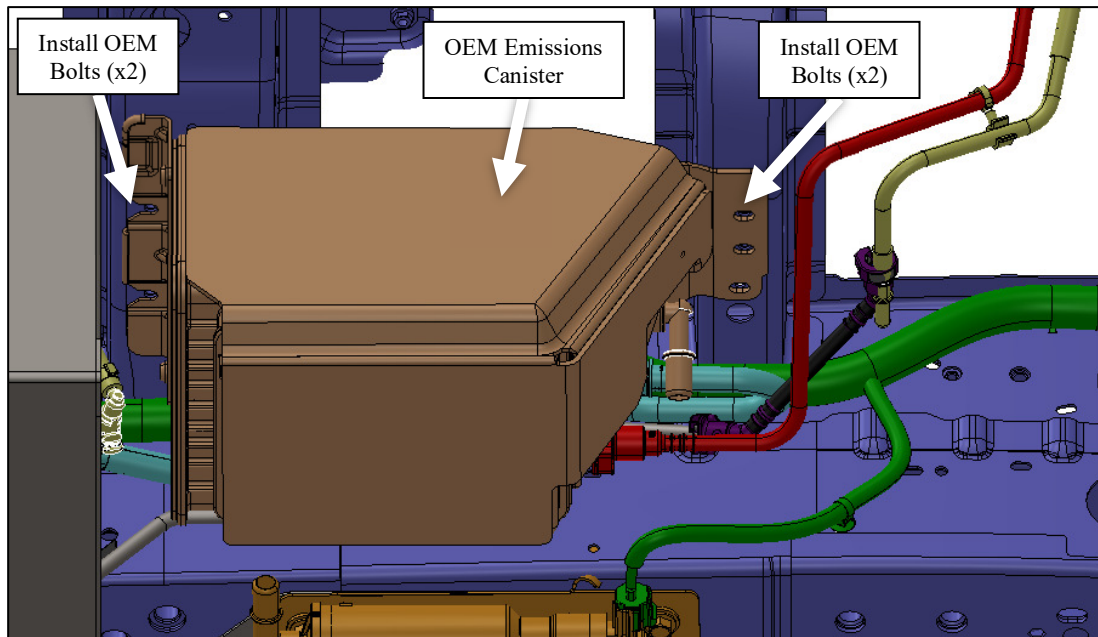

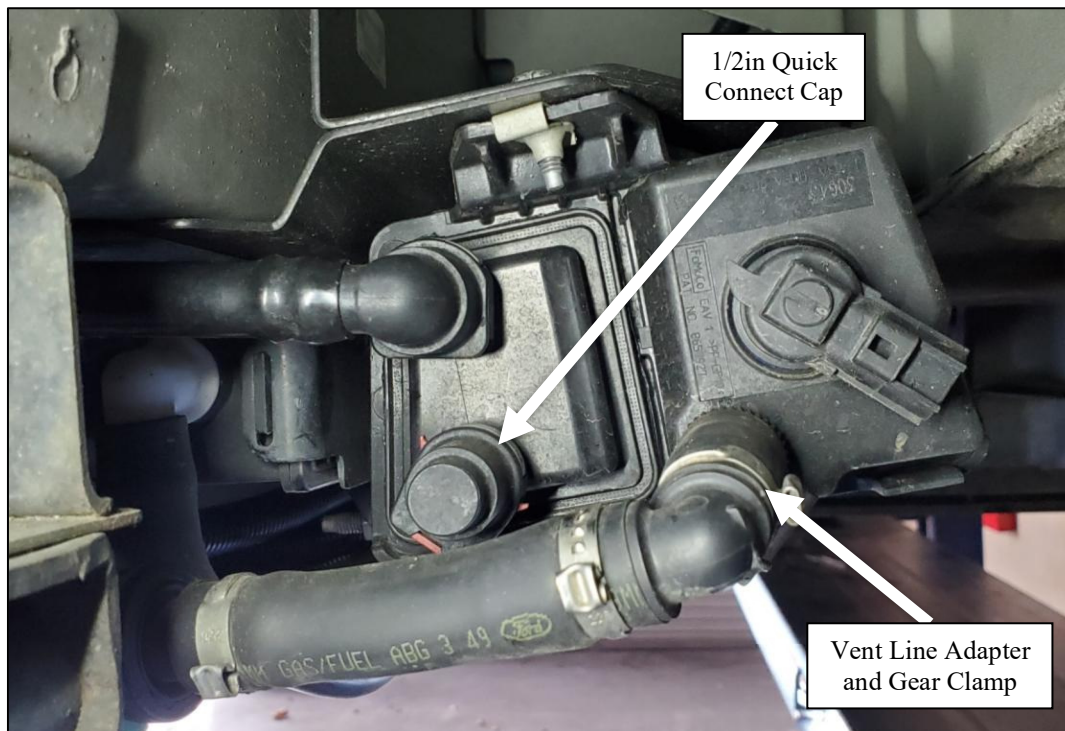
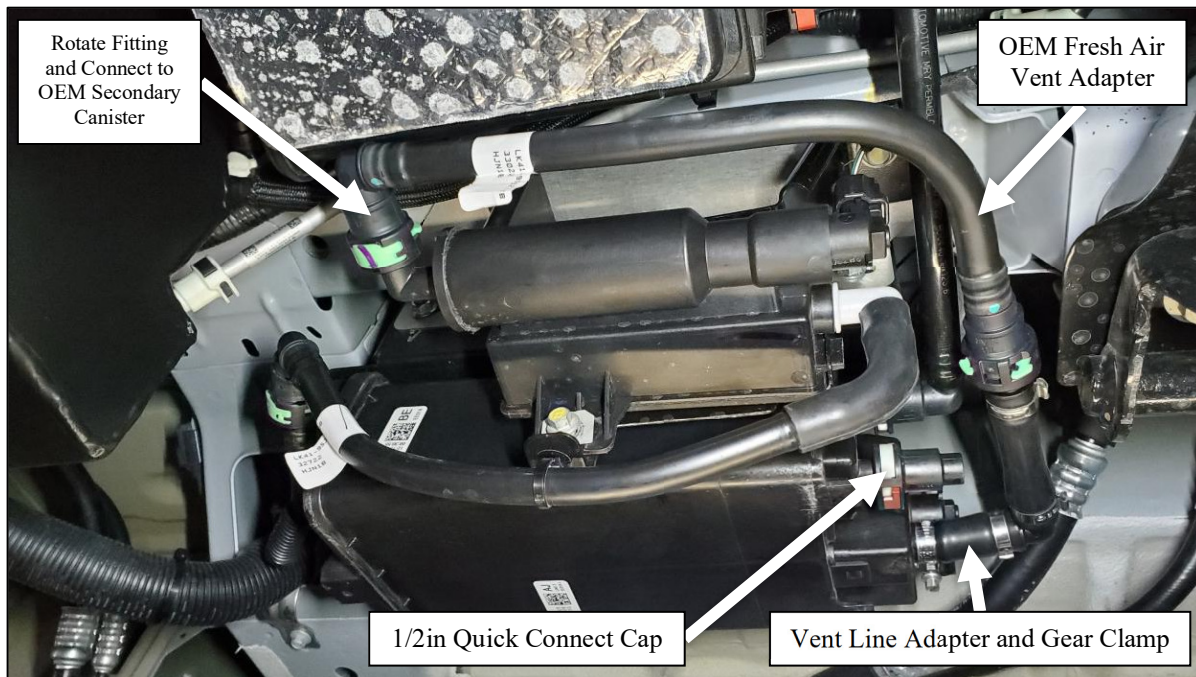

24. Install the TFI Vent Line Adapter (rubber hose with gear clamp) on the 5/8" barbed port of the TFI Emissions Canister with the provided gear clamp. Point the male quick-connect fitting towards the OEM Emissions Canister. Torque the gear clamp per IS-484.
25. Locate the OEM Fresh Air Vent Adapter. Gripping the tube firmly, rotate the 90-degree elbow fitting roughly 90 degrees such that it is pointing the same direction as the straight fitting on the other end of the tube. Install the straight fitting into the male fitting from the TFI Vent Line Adapter. Insert the 90-degree elbow fitting into the rear male port of the OEM filter assembly.
26. Install the 1/2in quick-connect cap on the on the 1/2in male quick-connect port of the TFI Emissions Canister.

27. Install the TFI Canister Adapter Hose Assembly. Insert the 90-degree elbow fitting into the TFI Canister, then rotate the hose assembly and insert the 45-degree fitting into the 5/8in vent port on the OEM canister.

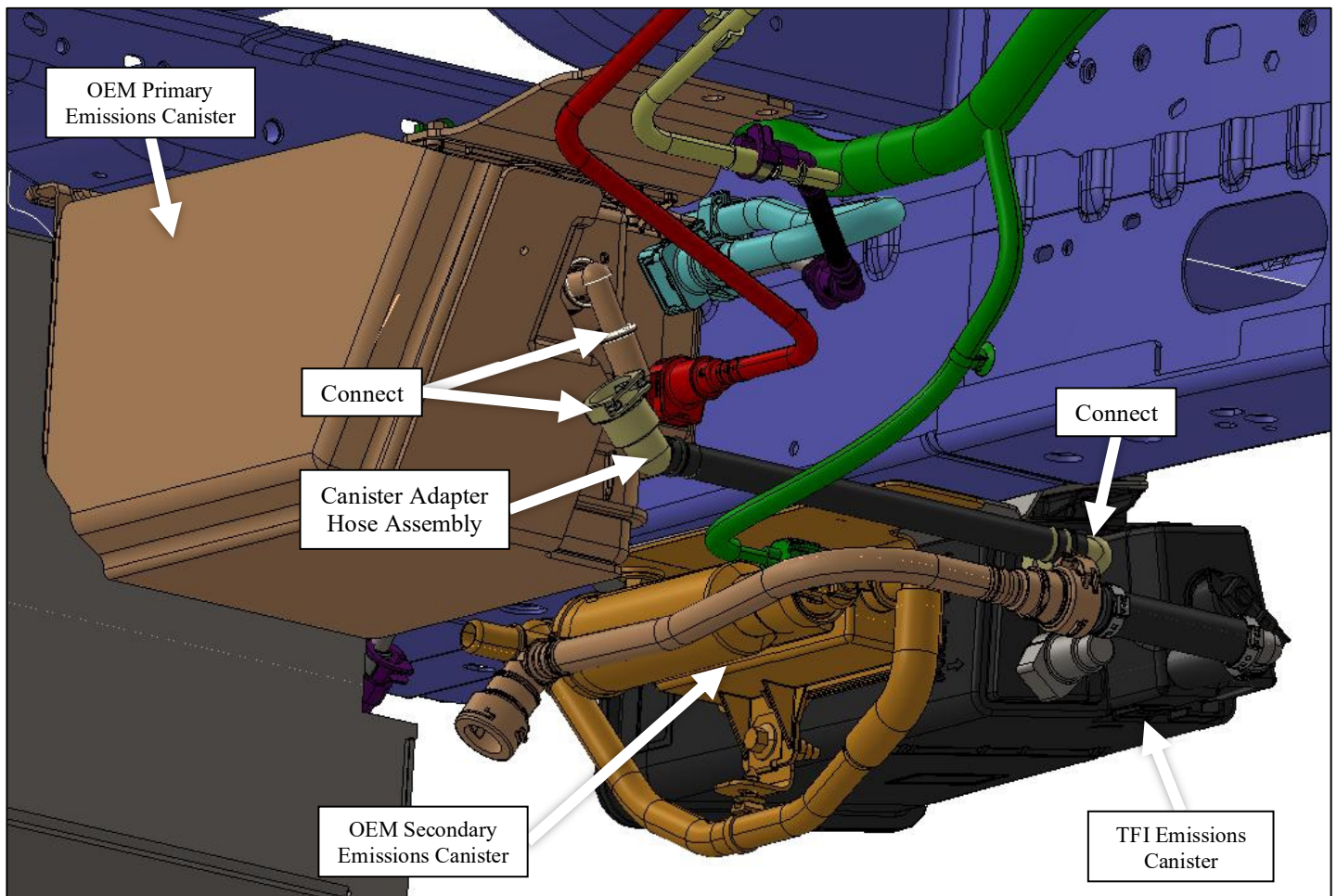

## SECTION 8: SECURE THE OEM WIRE HARNESS CUTAWAY/CAB CHASSIS VANS ONLY

**NOTE:** If you have a Passenger Van or Cargo Van chassis, please skip this section and continue. These steps are for securing the wire harness that is relocated on Cutaway or Cab Chassis Vans only.

1. Secure the wire harness to the outside of the driver's side frame rail with provided 1in clamp and self-tapping screw. Install the self-tapping screw approximately 4in above the bottom of the frame rail and 7in in front of the front tank cross member.

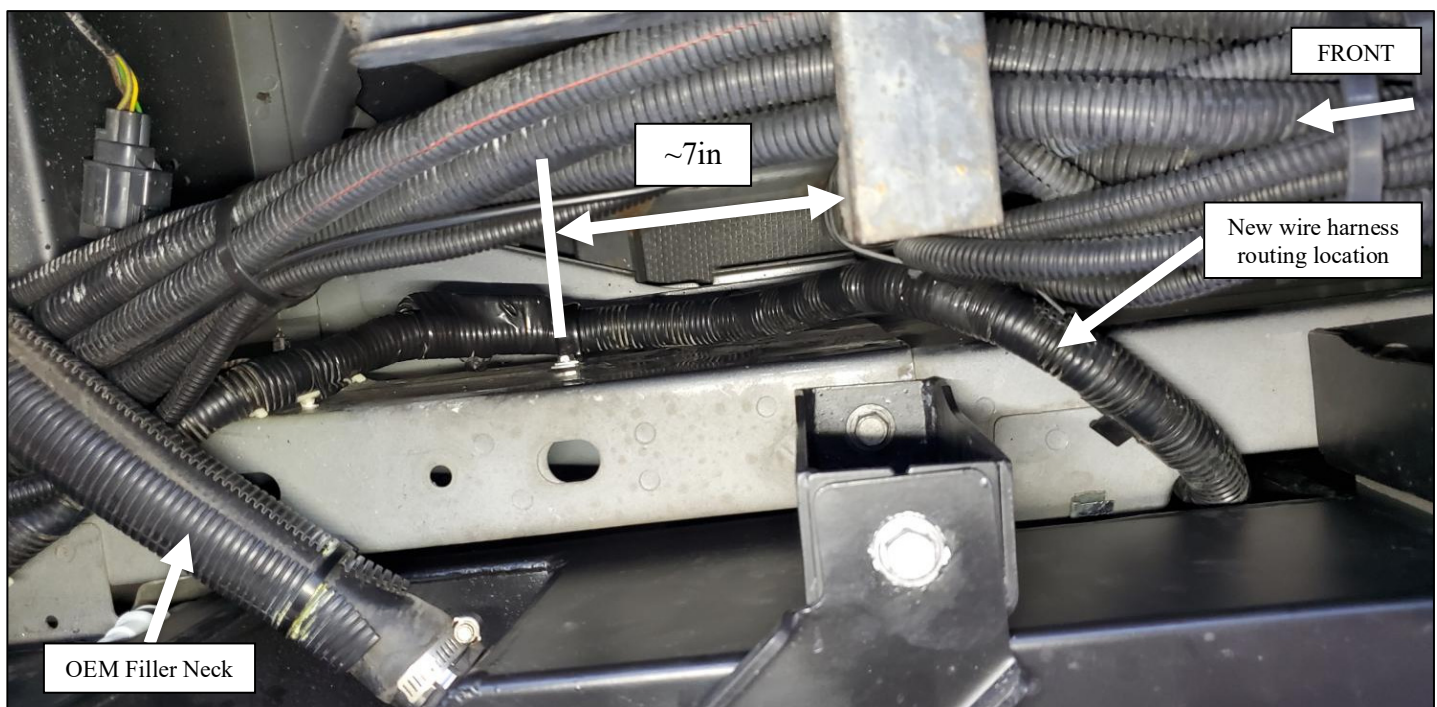
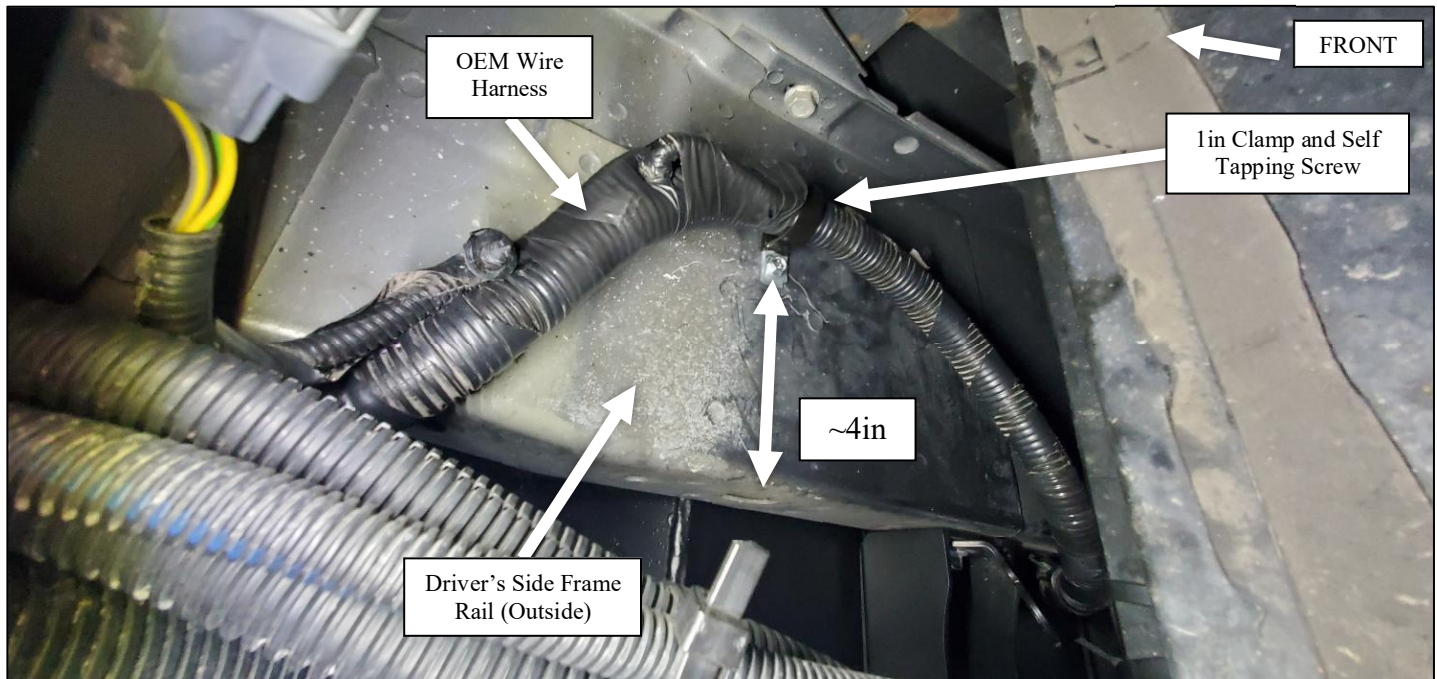

2. Secure the wire harness to the bottom of the driver's side frame rail with provided 1 in clamp and self-tapping screw.
  - a. Install one clamp roughly 4.5in to the rear of the center of the crossmember.
  - b. Install the second clamp roughly 3in to the front of the center of the cross member.
  - c. Check that the wire harness is pinched by the fuel tank and has enough clearance to move freely.

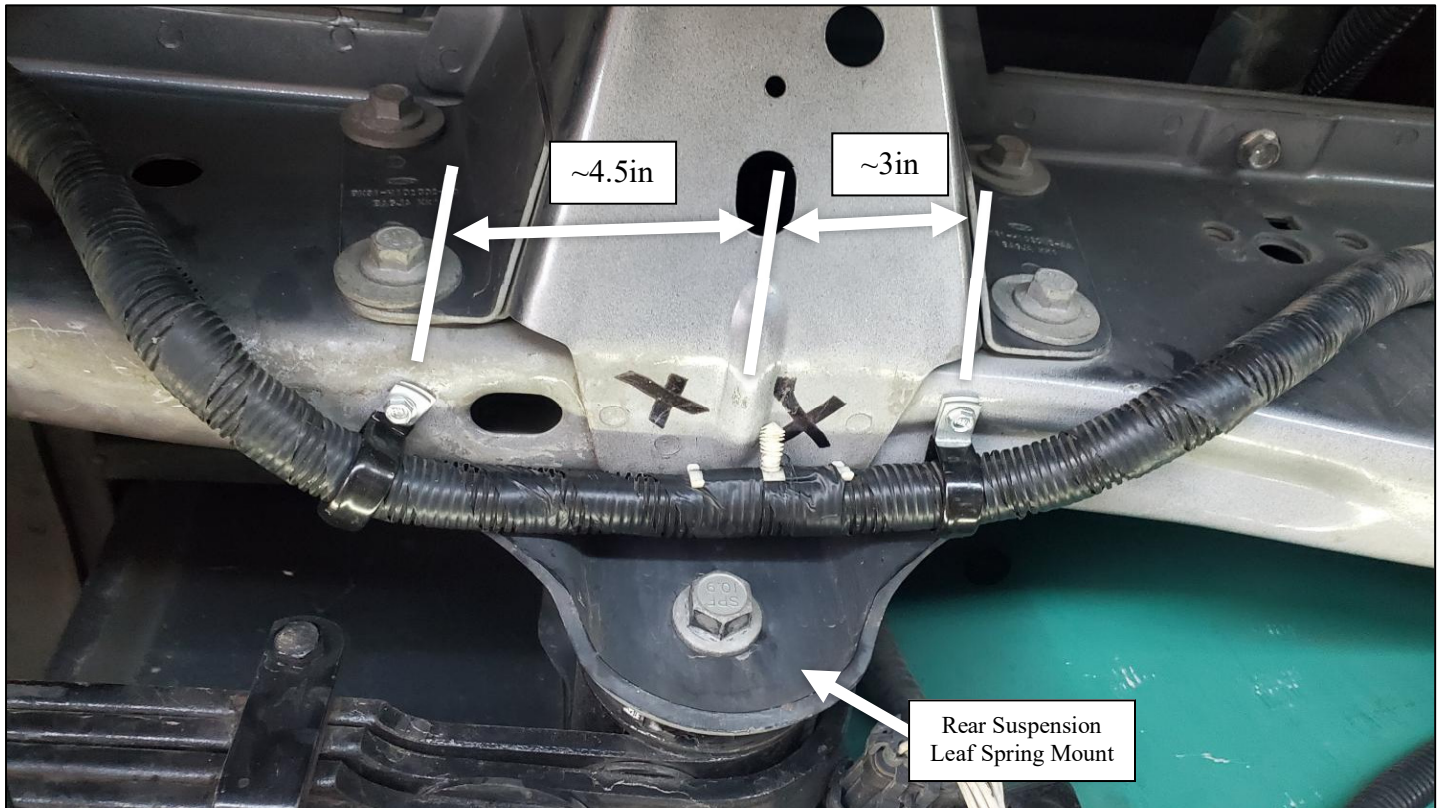

## **SECTION 9: FINALIZING THE INSTALLATION**

1. Make sure all the fuel, fill, vent lines, and electrical wires are not kinked or pinched, close to any heat source, or in contact with any sharp or moving objects. Confirm that the vent line has a continuous downwards slope from the filler neck to the tank.
2. Reconnect the vehicles battery and secondary battery if used.
3. Fill the fuel tank and check for any leaks under the vehicle.
4. Pressurize the fuel system.
  - a. Cycle the ignition key to IGNITION ON / ENGINE OFF and wait 3 seconds to pressurize the fuel system.
  - b. Check for fuel leaks under the vehicle before starting the engine.
5. Start the engine and verify that there are no fuel leaks under the vehicle.
6. Apply the CARB EO label to the underside of the hood, per supplemental instruction sheet IS-946.

Complete Final Installation Checklist below.

- All hose clamps are tight and secure.
- All nuts and bolts are torqued to spec (See IS-484).
- Mounting brackets and straps are secure.
- Sending unit bolts are secure and torque to spec.
- All fuel lines are secure with no kinks.
- Tank does not interfere or rub with other vehicle components.
- Tank calibration is accurate.

*Congratulations on a successful installation!*