

RELIABILITY™

Provin

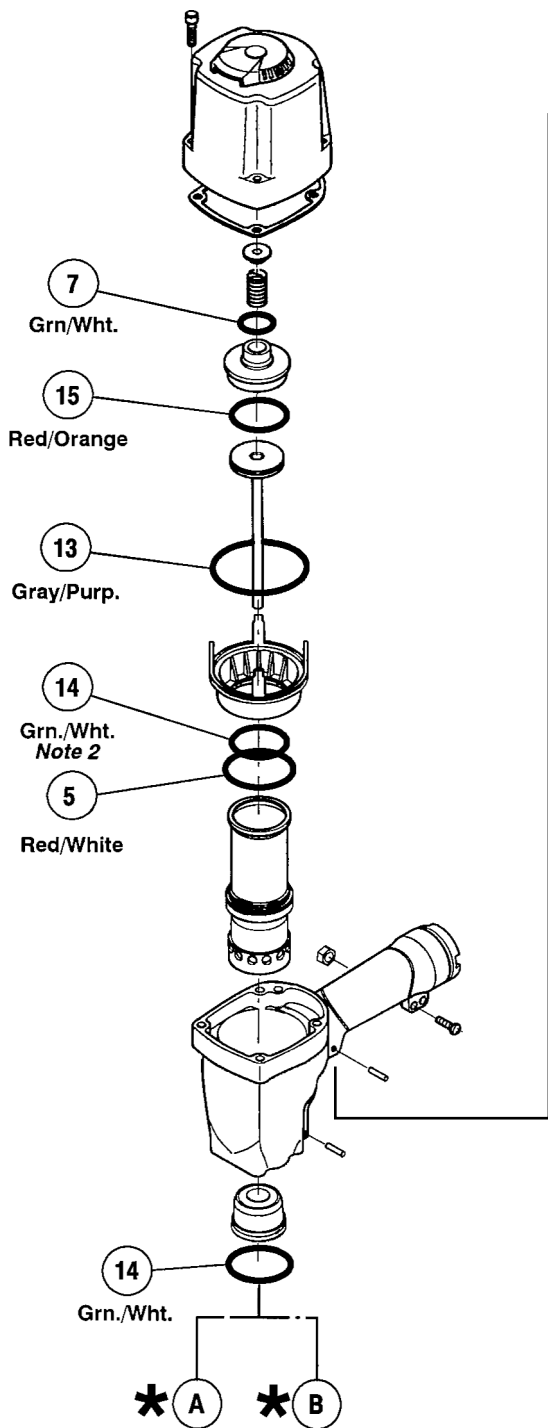

NV 75AG & NR 65AK NV 75AG Only

NR 65AK &
NR 65AK(S)

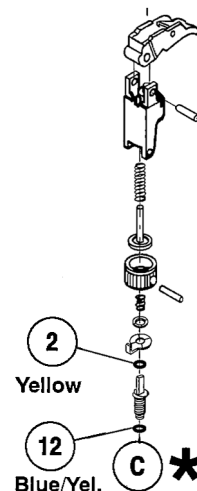
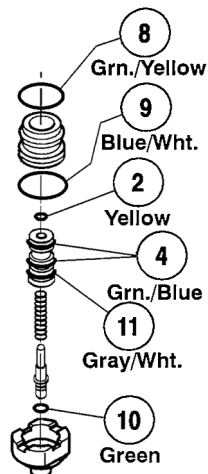

Contents of O-Ring Kit KT-HA-750

Key Number	Quantity	Performance Provin, Inc.			Equivalent Hitachi® Part Number
		Part Number	Color Code		
1	2	OR-PP-818	Red/Blue	Note 4	874-436
2	2	OR-PP-945	Yellow	Note 6	981-317
3	2	OR-PP-971	Grn./Blue	Notes 3 & 5	872-645
4	2	OR-PP-971	Grn./Blue		878-925
5	1	OR-PP-1048	Red/White		877-368
6	1	OR-PP-1117	Green	Note 5	880-330
7	1	OR-PP-1118	Grn./Wht.		876-796
8	1	OR-PP-1199	Grn./Yel.		877-699
9	1	OR-PP-1222	Blue/Wht.		878-885
10	1	OR-PP-1304	Green		878-888
11	1	OR-PP-1456	Gray/Wht.		878-887
12	1	OR-PP-1633	Blue/Yel.	Note 5	872-822
13	1	OR-PP-1650	Gray/Purp.		878-863
14	2	OR-PP-1651	Grn./Wht.	Note 2	882-874
15	1	OR-PP-9981	Red/Orange		883-431

Note 2: Care should be exercised when installing the cylinder plate onto the cylinder since O-Ring OR-PP-1651 (key #14) can be easily pinched and cause leaks between the main pressure reservoir and the piston return chamber.

Note 3: One O-Ring OR-PP-971 (key #3) is located on the magazine holder shaft on model NV75AG.

Note 4: One O-Ring OR-PP-818 (key #1) is located on the nail guide shaft.

Note 5: Not used on NR65AK.

Note 6: Quantity one of OR-PP-945 used on NR65AK, NR65AK(S)

*Generously grease all O-rings at time of assembly

Note: Read and understand the safety information printed on the reverse side before repairing any tools.
Nota: Lea y comprende la información de seguridad impresa al reverso antes de reparar cualquier herramienta.

10/9/2006

Exploded View and O-ring List for
HITACHI NV75AG, NR65AK & NR65AK(S)

VL-HA-750

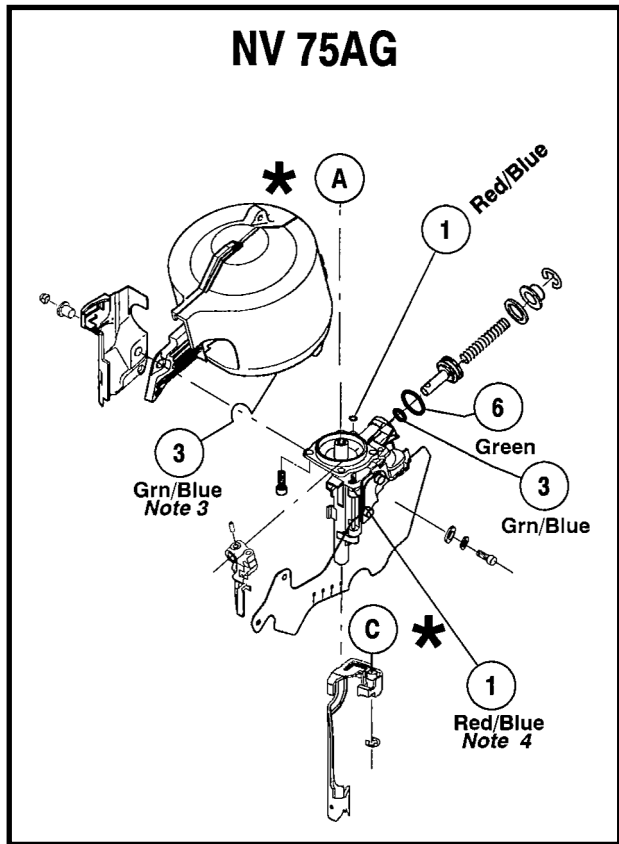

CAUTION CAUTION CAUTION

ALWAYS WEAR SAFETY GLASSES WITH SIDE SHIELDS WHEN USING PNEUMATICALLY OPERATED FASTENER DRIVING TOOLS

NEVER POINT THE TOOL AT YOURSELF OR ANYONE ELSE

NEVER BYPASS OR REMOVE ANY SAFETY DEVICE

ALWAYS FOLLOW THE ORIGINAL MANUFACTURE'S SAFETY AND SERVICE INSTRUCTION

NEVER ATTEMPT TO SERVICE OR REPAIR A PNEUMATICALLY OPERATED TOOL WITH THE COMPRESSES AIR LINE CONNECTED TO THE TOOL

NEVER LEAVE A PNEUMATICALLY OPERATED TOOL UNATTENDED WITH THE COMPRESSES AIR LINE CONNECTED

ALWAYS FOLLOW THE ORIGINAL TOOLS MANUFACTURE'S DISASSEMBLY, ASSEMBLY, AND TOOL INSPECTION PROCEDURES

PRECAUTION PRECAUTION PRECAUTION

SIEMPRE USE LENTES DE SEGURIDAD CON PROTECTORES LATERALES AL USAR HERRAMIENTAS DE IMPULSO CON SUJETADOR DE OPERACIÓN NEUMÁTICA

NUNCA APUNTE A SI MISMO O A OTRA PERSONA CON LA HERRAMIENTA

NUNCA EVITE O RETIRE ALGÚN DISPOSITIVO DE SEGURIDAD

SIEMPRE SIGA LAS INSTRUCCIONES DE SEGURIDAD Y SERVICIO DEL FABRICANTE ORIGINAL DE LA HERRAMIENTA

NUNCA INTENTE HACER MANTENIMIENTO O REPARAR UNA HERRAMIENTA DE OPERACIÓN NEUMÁTICA CON LA LINEA DE AIRE COMPRIMIDO CONECTADA A LA HERRAMIENTA

NUNCA DEJE SIN ATENCIÓN UNA HERRAMIENTA DE OPERACIÓN NEUMÁTICA CON LA LINEA DE AIRE COMPRIMIDO CONECTADA

SIEMPRE SIGA LOS PROCEDIMIENTOS DE DESMONTAJE, MONTAJE, E INSPECCIÓN DEL FABRICANTE ORIGINAL DE LA HERRAMIENTA

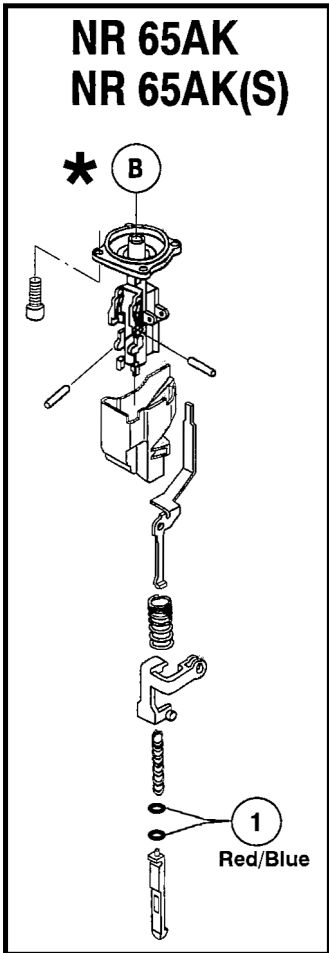

O-Ring Kit KT-HA-750

For use on the following tool models.
Kit contains all O-Rings in these tools.

HITACHI	NV75AG
	NR65AK
	NR65AK(S)



7 1 2 2 1 8 2 4 0 3 0 6