



OPERATIONS & PARTS MANUAL

FOR MODELS:

- BE-BRTH65
- BE-BRTR7

| PURCHASE DATE | MODEL NO. | SERIAL NUMBER |
|---------------|-----------|---------------|
| | | |
| DEALER | | |

TABLE OF CONTENTS

| | |
|-----------|---------------------------|
| 3 | SAFETY |
| 7 | ASSEMBLY |
| 9 | OPERATION |
| 13 | MAINTENANCE & STORAGE |
| 17 | STORAGE & TROUBLESHOOTING |
| 19 | PARTS LIST |

SAFETY

OWNER'S RESPONSIBILITY

Accurate assembly and safe and effective use of the rototiller is the owner's responsibility.

- Read and follow all safety instructions.
- Carefully follow all assembly instructions.
- Maintain the tiller according to directions and schedule included in this operator's manual.
- Ensure that anyone who uses the tiller is familiar with all controls and safety precautions.

SPECIAL MESSAGES

Your manual contains special messages to bring attention to potential safety concerns, machine damage as well as helpful operating and servicing information.

Please read all the information carefully to avoid injury and machine damage.

NOTE: General information is given throughout the manual that may help the operator in the operation or service of the machine.

IMPORTANT SAFETY PRECAUTIONS

Please read this section carefully.

Operate the tiller according to the safety instructions and recommendations outlined here and inserted throughout the text. Anyone who uses this tiller must read the instructions and be familiar with the controls. Your tiller is equipped with a safety device that enables you to stop the wheels and tines quickly in an emergency.

Learn how the drive safety control lever operates and how to control the tiller at all times.



This symbol points out important safety instructions which if not followed could endanger your personal safety. Read and follow all instructions in this manual before attempting to operate this equipment.

⚠ DANGER

INDICATES A SERIOUS INJURY OR FATALITY WILL RESULT IF THE SAFETY INSTRUCTIONS THAT FOLLOW THIS SIGNAL WORD ARE NOT OBEYED

⚠ WARNING

INDICATES A SERIOUS INJURY OR FATALITY COULD RESULT IF THE SAFETY INSTRUCTIONS THAT FOLLOW THIS SIGNAL WORD ARE NOT OBEYED

⚠ CAUTION

INDICATES YOU CAN OR YOUR EQUIPMENT CAN BE HURT IF THE SAFETY INSTRUCTIONS THAT FOLLOW THIS SIGNAL WORD ARE NOT OBEYED

⚠ IMPORTANT

INDICATES HELPFUL INFORMATION FOR PROPER ASSEMBLY, OPERATION, OR MAINTENANCE OF YOUR EQUIPMENT

⚠ WARNING

YOU MUST READ, UNDERSTAND AND COMPLY WITH ALL SAFETY AND OPERATING INSTRUCTIONS IN THIS MANUAL BEFORE ATTEMPTING TO SETUP AND OPERATE YOUR ROTOTILLER

FAILURE TO COMPLY WITH ALL SAFETY AND OPERATION INSTRUCTIONS CAN RESULT IN LOSS OF THE MACHINE CONTROL, SERIOUS PERSONAL INJURY TO YOU AND/OR BYSTANDERS, AND RISK OF EQUIPMENT AND PROPERTY DAMAGE. THE TRIANGLE IN THE TEXT SIGNIFIES IMPORTANT CAUTIONS OR WARNINGS WHICH MUST BE FOLLOWED.

CALIFORNIA PROPOSITION 65 WARNING

ENGINE EXHAUST FROM THIS PRODUCT CONTAINS CHEMICALS KNOWN TO THE STATE OF CALIFORNIA TO CAUSE CANCER, BIRTH DEFECTS, OR OTHER REPRODUCTIVE HARM.

- Do not allow children to operate this rototiller. Keep small children away from the area being tilled. Do not allow adults to operate the tiller without proper instruction.

PREPARATION

- Dress appropriately when operating the tiller. Always wear sturdy footwear. Never wear sandals, sneakers, or open shoes, and never operate the tiller with bare feet. Do not wear loose clothing that might get caught in moving parts.
- Carefully inspect the area to be tilled and remove all foreign objects. Do not till above underground water lines, gas lines, electric cables, or pipes. Do not operate the tiller in soil with large rocks and foreign objects which can damage the equipment.
- Disengage all clutches and leave all control levers in the neutral position before starting the engine.
- Handle fuel with care; it is highly flammable.
 - Use an approved fuel container.
 - Never add fuel to a running engine or hot engine.
 - Fill fuel tank outdoors with extreme care. Never fill fuel tank indoors.
 - Replace gasoline cap securely and clean up spilled fuel before restarting.
- Never attempt to make any adjustments while the engine is running.

OPERATION

- Never operate the tiller without guards, covers, and hoods in place.
- Never start the engine or operate the tiller with the wheels in the free-wheel position. Make sure the wheel lock pins are engaged through the wheel hubs and wheel axle. The wheels act as a brake to keep the tiller at a controlled speed. Disengage wheel lock pins to permit free-wheeling only when engine is stopped.
- Keep hands, feet, and clothing away from rotating parts. Keep clear of tiller tines at all times.
- Tines and wheels rotate when tiller is engaged in forward or reverse-- in forward, tines and wheels rotate when the drive safety control lever (FORWARD), is pushed down toward the handlebar. In reverse, wheels and tines rotate when the drive safety control lever (REVERSE), is pulled back toward the operator. Releasing the reverse handle to the neutral position stops the wheels and tines. Do not operate both drive safety control levers at the same time.
- Be extremely cautious when operating in reverse. Take extra care to avoid slipping or falling, and keep hands and feet clear of tines.
- Use extreme caution when operating on or crossing gravel drives, walks, or roads. Stay alert for hidden hazards or traffic.

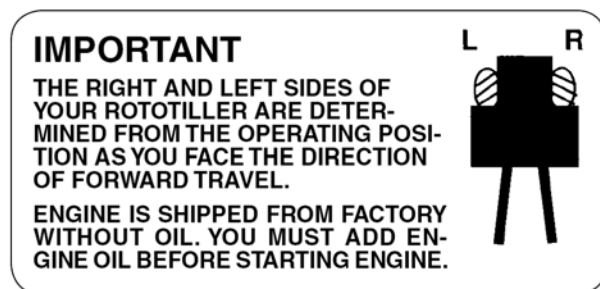

- After striking a foreign object, stop the engine, remove the wire from the spark plug, thoroughly inspect the tiller for any damage, and repair the damage before restarting and operating the tiller.
- If vegetation clogs the tines, raise the handlebars to elevate the tines, and run the tiller in reverse. If this does not clean clogged vegetation from the tines, STOP THE ENGINE AND DISCONNECT THE SPARK PLUG WIRE before removing vegetation by hand.
- Engine muffler will be hot from operation. Do not touch it with bare skin or a severe burn may result.
- If the unit should start to vibrate abnormally, stop the engine and check immediately for the cause. Vibration is generally a warning of trouble.

- Do not run the engine indoors; exhaust fumes are deadly.
- Do not overload the machine capacity by attempting to till too deep at too fast a rate.
- Never operate the machine at high transport speeds on slippery surfaces. Look behind and use care when backing.
- Never allow bystanders near the unit.
- Use only attachments and accessories approved by the manufacturer of the tiller.
- Never operate the tiller without good visibility or light.
- Be careful when tilling in hard ground. The tines may catch in the ground and propel the tiller backward. If this occurs, let go of the handlebars and do not restrain the machine.
- Take all possible precautions when leaving the machine unattended. Disengage all control levers, stop the engine, wait for all moving parts to stop, and make certain guards and shields are in place.
- When leaving the operating position for any reason:
 - shut off the engine.
 - wait for all moving parts to stop.

MAINTENANCE AND STORAGE

- Keep machine, attachments, and accessories in safe working condition.
- Check shear bolts, engine mounting bolts, and other bolts at frequent intervals for proper tightness to be sure the equipment is in safe working condition.
- To prevent accidental starting, always disconnect and secure the spark plug wire from the spark plug before performing tiller maintenance.
- Never run the engine indoors. Exhaust fumes are deadly.
- Always allow muffler to cool before filling fuel tank.
- Never store equipment with gasoline in the tank inside a closed building where fumes may reach an open flame or spark. Allow the engine to cool before storing in any building.
- Always refer to the operator's guide instructions for important details if the tiller is to be stored for an extended period.

SAFETY DECALS

This rototiller unit has been designed and manufactured to provide you with the safety and reliability you would expect from an industry leader in outdoor power equipment manufacturing.

Although reading this manual and the safety instructions it contains will provide you with the necessary basic knowledge to operate this equipment safely and effectively, we have placed several safety labels on the tiller to remind you of this important information while you are operating the unit.

These important safety labels are illustrated below, and are shown here to help familiarize you with the location and content of the safety messages you will see as you perform normal tilling operations. Please review these labels now. If you have any questions regarding their meaning or how to comply with these instructions, reread the complete safety instruction text on the preceding pages, or contact your local dealer.

Should any of the safety labels become unreadable because of being worn, faded, or otherwise damaged during the use of your tiller, please use the part number information provided to order a replacement label from your local authorized dealer.

The safety labels are easily applied, and will act as a constant visual reminder to you, and others who may use the equipment. Follow the safety instructions necessary for safe, effective operation of your rototiller.

⚠ WARNING

AVOID SERIOUS INJURY

- Read operator's manual(s) before operating.
- Know the location and function of all controls.
- Keep all shields and guards in place and working while running.
- Never allow children to operate tiller.
- Dress appropriately—wear sturdy footwear.
- Carefully inspect area to be tilled—remove large rocks and other foreign objects.
- DO NOT till above underground electric, water, gas, or other utility lines and pipes.
- STOP THE ENGINE AND DISCONNECT THE SPARK PLUG WIRE before removing debris or servicing unit.
- When leaving the operating position for any reason:
 - shut off the engine.
 - wait for all moving parts to stop.

⚠ WARNING

WHEELS ACT AS BRAKES

- Never start or operate tiller with wheels in the Free Wheel position, Make sure wheel lockouts are engaged through wheel hubs and axle.
- Wheels act as brakes to keep the tiller at a controlled speed, Disengage wheel lockouts ONLY when engine is stopped.

OPERATION

REFER TO OPERATOR'S MANUAL FOR DETAILED OPERATING INSTRUCTIONS TO START:

1. Release drive control levers to neutral position.
2. Lower the drag stake so that tines do not touch the ground.
3. Check position of wheels and wheel lockouts.
4. Slide choke control to choke position.
5. Move throttle control lever to fast position.
6. Pull starter rope.

⚠ DANGER



AVOID INJURY FROM ROTATING TINES!

Keep hands, feet, and clothing away.

- Tines rotate when tiller is engaged in forward or reverse.
- Tines and wheels rotate when drive control levers are pulled down.
- In reverse, tines and wheels rotate when the reverse handle is pulled back toward the operator.
- Releasing the drive control levers to the neutral position stops the wheels and tines.

⚠ WARNING

DO NOT START ENGINE UNLESS BELT COVER IS ATTACHED. KEEP HANDS, FEET, AND CLOTHING AWAY FROM MOVING BELTS AND PULLEYS. FAILURE TO COMPLY COULD RESULT IN INJURY. SEE OWNER'S MANUAL FOR FULL SAFETY INSTRUCTIONS.

⚠ WARNING



Read and follow Operating Instructions before running engine.



Gasoline is flammable. Allow engine to cool at least 2 minutes before refueling.



Engines emit carbon monoxide, DO NOT run in enclosed area.



Muffler area temperature may exceed 150°F. Do not touch hot parts.

FORWARD

REVERSE

ASSEMBLY INSTRUCTIONS

The rototiller comes fully assembled except for a few parts. The following instructions will help you assemble and adjust the tiller's depth regulator, cable tension, and handlebar height. You will need two 9/16" wrenches to complete the assembly.

STEP 1 Install the Depth Regulator

1. Install the depth regulator into the top of the depth regulator Bracket with handle facing rearward.
2. Insert depth regulator pin through depth regulator bracket and top hole of depth regulator-tines should clear the ground.

STEP 2 Attach ex-arm-rest stems to the Tiller

1. The ex-arm-rest stems on outside of the Transmission cover and align the lower boles.
2. Insert one 3/8"-16x 1" bolt for each side in lower holes.
3. Start 3/8"-16 nuts on each bolt.
4. Insert one 3/8"-16x 1" bolt for each side in Upper holes at desired handlebar height.
5. Tighten all the nuts.

IMPORTANT

THE RIGHT AND LEFT SIDES OF YOUR ROTOTILLER ARE DETERMINED FROM THE OPERATING POSITION AS YOU FACE THE DIRECTION OF FORWARD TRAVEL.

ENGINE IS SHIPPED FROM FACTORY WITHOUT OIL. YOU MUST ADD ENGINE OIL BEFORE STARTING ENGINE.

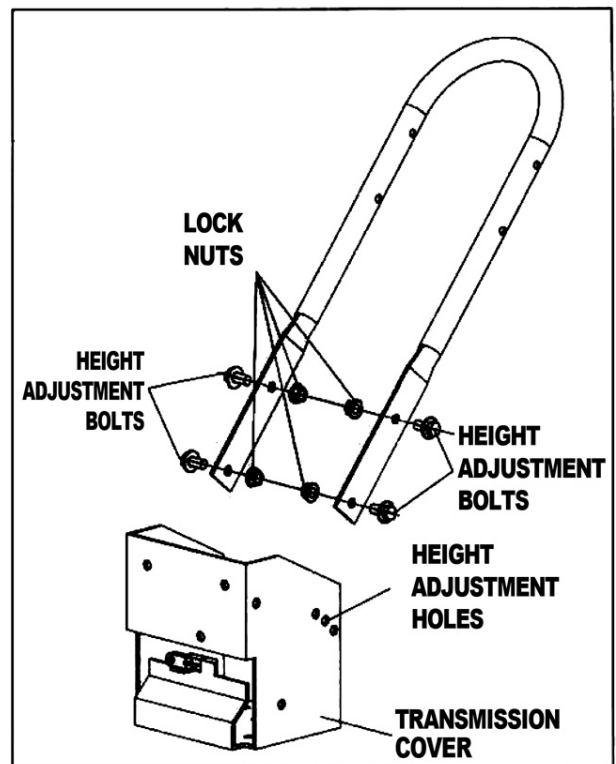
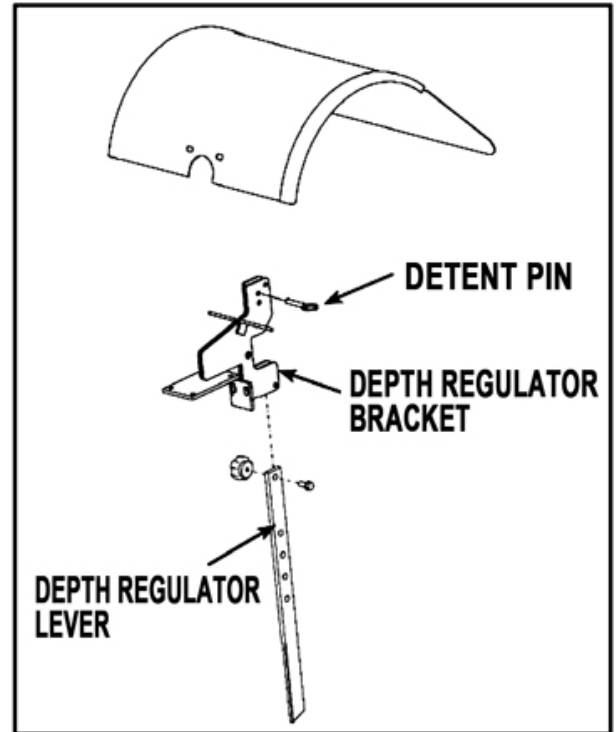
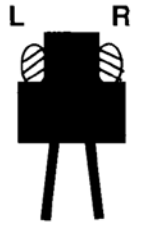

STEP 3: Attach handle bar to the Tiller

1. Insert four fastness bolts for each side in every holes.
2. Start fastness nuts on each bolt.
3. Tighten all the nuts.

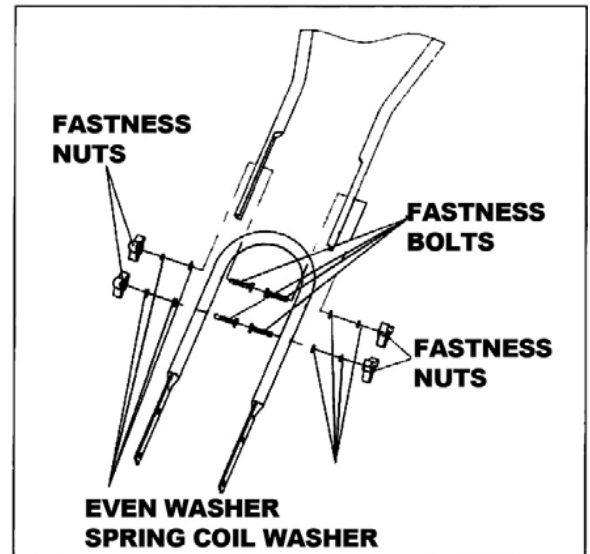

STEP 4: Fill Engine Crankcase

IMPORTANT

Engine is shipped from factory without oil. Engine oil must be added before starting engine.

1. Add oil according to engine manual. Do not overfill. Use clean, high quality detergent oils. Do not mix oil with gasoline. Oil level must be full. Check the oil level by removing oil fill plug.
2. Always check oil level before starting engine. Refer to engine manual for capacity and type of oil to use.

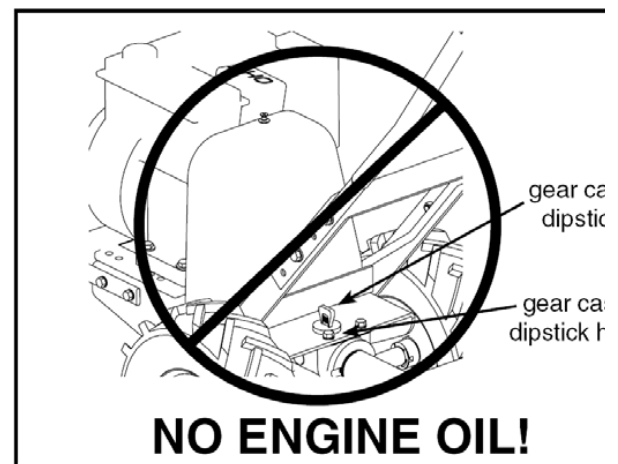

OPERATION

PRE-START INSPECTION

1. Make sure all safety guards are in place and all nuts and bolts are secure.
2. Check oil level in engine crankcase. See your engine manual for procedure and specifications.
3. Inspect air cleaner for cleanliness. See your engine manual for procedure.
4. Check the fuel supply. Fill the fuel tank no closer than 1 inch from top of tank to provide space for expansion. See your engine manual for fuel recommendations.
5. Be sure spark plug wire is attached and spark plug is tightened securely.
6. Check position of wheels and wheel lockouts.
7. Check depth regulator lever position.
8. Examine underneath and around engine for signs of oil or fuel leaks.
9. Inspect fuel hoses for tightness and fuel.
10. Look for signs of engine damage.
11. Remove excessive debris from muffler area and recoil starter.

START- UP

The controls required to start and run the rototiller are located on the engine and are marked “choke” and “Throttle”. A more detailed description of engine operation and all related precautions and procedures can be found in the engine manufacturer’s manual that accompanies each tiller.

COLD STARTS

1. Move choke lever to full choke position.
2. Move throttle lever to “start”.
3. Pull starting rope out slowly one time and allow to return normally.
4. Pull starting rope out rapidly, and allow rope to return normally.

When engine starts, gradually move choke lever to “no choke” position and increase throttle speed.

CAUTION

PLEASE DO NOT START YOUR TILLER UNTIL YOU HAVE READ THE MANUAL THAT CAME WITH YOUR ENGINE, AND THE SECTIONS IN THIS MANUAL ENTITLED CONTROLS, ADJUSTMENTS AND SAFETY. IF YOU HAVE READ THESE, FOLLOW THE STEPS BELOW TO START YOUR TILLER, ALWAYS PERFORM THIS PRE-START CHECKLIST BEFORE STARTING THE ENGINE

WARNING

GASOLINE IS HIGHLY FLAMMABLE AND MUST BE HANDLED WITH CARE. NEVER FIL THE TANK WHEN THE ENGINE IS HOT OR RUNNING, ALWAYS MOVE OUTDOORS TO FILL THE TANK
WHEELS MUST ALWAYS BE LOCKED IN THE TILLING POSITION WHEN ENGINE IS RUNNING. DO NOT OPERATE THE TILLER WITH THE WHEEL LOCKOUTS UNLOCKED. ALWAYS SET THE WHEELS IN TILLING POSITION BEFORE STARTING ENGINE.
ALWAYS PUT THE DEPTH REGULATOR LEVER IN THE TRANSPORT POSITION BEFORE STARTING ENGINE. TINES SHOULD CLEAR THE GROUND.

IMPORTANT

ENGINE IS SHIPPED FROM FACTORY WITHOUT OIL. YOU MUST ADD ENGINE OIL BEFORE STARTING ENGINE

DANGER

ALWAYS KEEP HANDS AND FEET CLEAR OF ROTATING MACHINE PARTS

RESTARTING A WARM ENGINE

Restarting an engine that is already warm from previous running does not normally require use of the choke.

1. Move throttle lever to “start” position.
2. Pull starting rope out rapidly until engine starts. Allow rope to return normally. Repeat until engine starts.
3. Adjust throttle speed to “high” for best tiller action.

IDLE SPEED

Use the “low” position on the throttle lever to reduce stress on the engine when tilling is not being performed. Lowering the engine speed to “idle” will help extend the life of the motor, as well as conserve fuel and reduce the noise level of the equipment.

OPERATING SPEED

For normal tilling, set the throttle lever to “fast”.

SHUTTING DOWN

To stop the engine at any time, turn engine ON/OFF switch to the off position. To stop wheels and tines at any time, release drive safety control levers to neutral position.

TILLING

1. Adjust the depth regulator lever to desired tilling depth.
NOTE: Raise depth regulator lever up one hole at a time, testing tiller operation after each raise. Raising depth regulator lever too high can result in loss of control of tiller!
2. Move the throttle control to fast.
3. Place the tiller in forward by pushing down on the drive safety control lever (FORWARD)--this will engage the wheels and tines.
NOTE: You can slow the tiller's forward advance at any time by putting slight downward pressure on the handlebars. You can stop the tiller by releasing the drive safety control levers to the neutral position.

⚠ WARNING

Temperature of muffler and near by areas may exceed 150° F, avoid these areas.

Do not move choke control to choke to stop engine. Backfire or engine damage may occur.

To stop wheels and tines at any time, release drive safety control levers to neutral position.

Always release drive safety control levers to neutral position before adjusting the depth of the regulator lever

⚠ DANGER

Engine and surrounding parts become extremely hot during normal use and will cause serious burn injuries if touched before the engine has cooled.

Allow engine cool completely before touching these hot surfaces

⚠ IMPORTANT

Practice operating the controls and tiller with tines out of ground before beginning to till. It is important that you know how to use the tiller properly, keep control at all times, stop the tines and wheels from turning, and stop the engine if necessary, if you do not know how to do these things, read the controls, adjustments and safety sections before proceeding

DRIVE SAFETY CONTROL LEVERS

FORWARD LEVER

Engages wheels and tines into forward.

Pushing down the drive safety control lever (FORWARD) toward the handlebar engages the wheels and tines. Releasing the lever stops the wheels and tines and brings the tiller to a complete stop.

⚠ CAUTION

Do not operate both "Forward" and "Reverse" drive safety control levers at the same time.

This information is provided here only to introduce the controls, do not start the engine at this time.

- As a safety precaution, the drive safety control levers will not lock in the forward or reverse position.
- As a safety precaution, the reverse drive safety control lever will not lock in reverse.
- To stop the wheels and tines at any time, release the drive safety control levers or release the reverse handle.
- Do not operate both the reverse and forward drive safety control levers at the same time

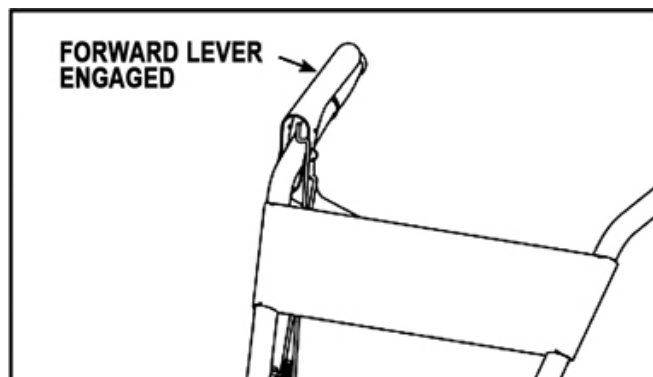

REVERSE LEVER

Engages wheels and tines into reverse.

Pulling the drive safety control lever(REVERSE) toward the handlebar reverses tiller.

Releasing the lever stops the wheels and tines.

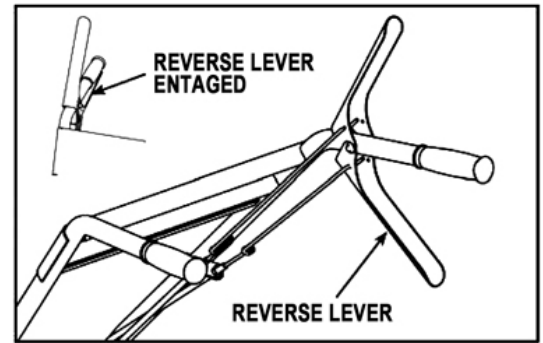

ADJUSTMENTS

WHEEL LOCK PINS

Place wheels in tilling position.

1. Remove lock pin. Align hole in axle with hole in wheel hub.
2. Insert lock pin through holes, fold lock pin ring to secure pin to axle.
3. Firmly lock wheel and axle together before tilling.
4. Repeat for other wheel.

NOTE: Always have both wheel lock pins in or out. Do not operate tiller with only one wheel locked.

To place wheels in free-wheel position.

1. Remove lock pin. Slide wheel inward toward machine.
2. Insert pin in axle only.
3. Wheel should turn freely on axle.

HANDLEBAR HEIGHT ADJUSTMENT

Adjust handlebar height.

The ideal height of the handlebar varies with operator height and the depth of tilling. To adjust handlebar height:

1. Unscrew nuts and remove top and bottom bolts on each side.
2. Align handlebar to desired holes on the lower handlebar mount.
3. Install bolts and nuts. Retighten.

⚠ WARNING
ENGINE SHOULD BE OFF BEFORE ADJUSTING ANY CONTROLS.
EXTREME CAUTION SHOULD BE USED WHEN OPERATING ROTOTILLER IN THE REVERSE DIRECTION.

DANGER!

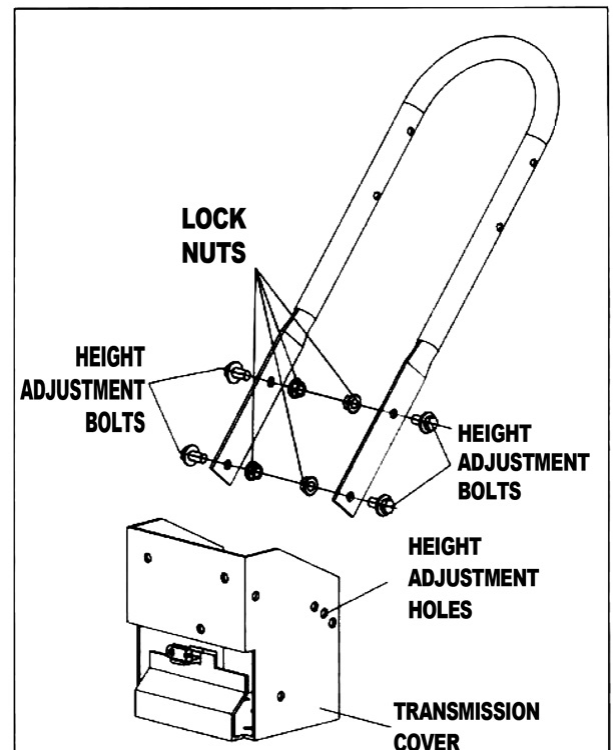
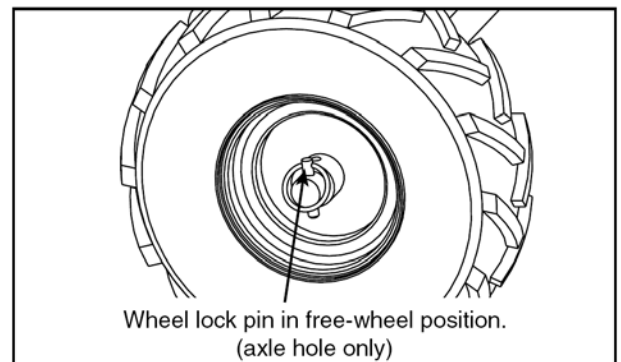

DEPTH REGULATOR LEVER

Tilling depth is controlled by the height of the depth regulator lever. To adjust tilling depth:

1. Remove detent pin.
2. Raise the depth regulator lever to position tines at chosen tilling depth.
3. Align hole in depth regulator lever with hole in depth regulator bracket and replace detent pin.

Depth Regulator Lever Down = Shallower tilling.

Place the detent pin in the top hole of the depth regulator lever for shallowest tilling.

Depth Regulator Lever Up = Deeper tilling.

Place the detent pin in the bottom hole of the depth regulator lever for deepest tilling.

⚠ WARNING

DO NOT ADJUST TILLING DEPTH UNLESS DRIVE SAFETY CONTROL LEVERS ARE RELEASED TO NEUTRAL POSITION.

ALWAYS SET THE DEPTH REGULATOR LEVER IN THE TRANSPORT POSITION BEFORE STARTING ENGINE, THAT IS, PLACE THE DETENT PIN IN THE HIGHEST HOLE OF THE DEPTH REGULATOR LEVER.

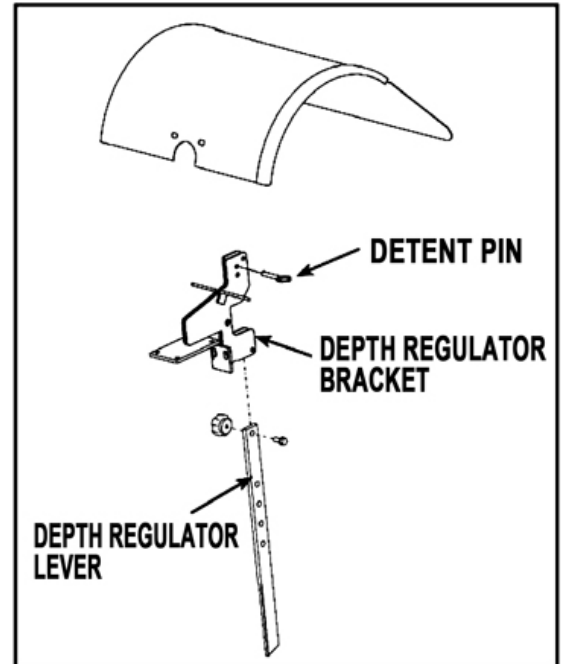

BELT TENSION ADJUSTMENT

Proper belt tension is critical to good performance. After 1/2 hour of operation, all cables may have to be adjusted due to initial stretch. Thereafter, check tension after every 2 hours of operation.

To increase belt tension:

1. Loosen upper jam nut. Turn nut up cable in 1/8" increments.
2. Tighten lower jam nut.
3. Check adjustment.

This procedure can be repeated until conduit adjustment bolts are fully adjusted. If no more adjustment can be made, belt may have to be replaced.

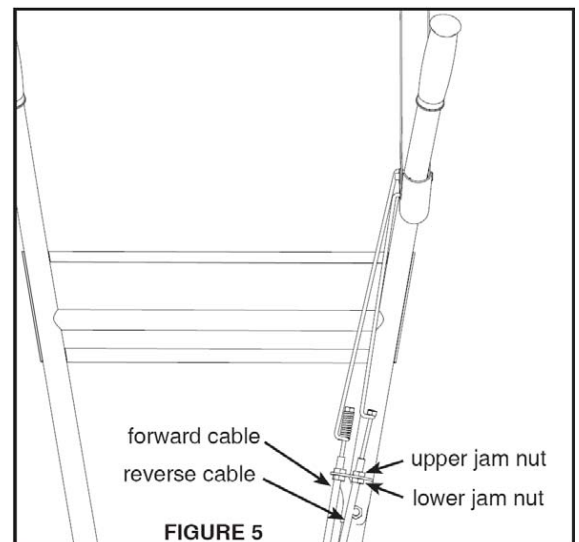

TILLING TIPS

The key to successful tilling is to begin with a shallow cut on the first pass, and then work an inch or two deeper on each successive pass.

⚠ WARNING

Extreme caution must be taken in selecting tilling depth, if you attempt to kill too deeply for soil conditions, that is, with the drag stake in too high a position, loss of control could result.

If removing material from the tines by hand, stop engine and remove spark plug wire first

- Tilling depth will vary with ground conditions.
 - When beginning to till in unbroken ground or in extremely hard soil, set the detent pin in the highest hole of the drag stake (follow instructions under Tilling section). This will allow for shallow tilling. With the drag stake in this position, make several light passes over the area to be tilled. Reset for deeper depths with successive passes.
 - If tiller jumps or skids uncontrollably, lower the drag stake by placing the detent pin in a higher hole. This will allow for shallower tilling. Hold firmly to the handlebars to control sudden lurches.
 - If weeds, tall grasses, vines, or other materials clog or jam the tines, reverse the tiller to unwind vegetation. Immediately release the drive control levers if the tines jam or you strike a foreign object.
- With drive control levers in neutral position, push throttle control to stop position to stop the engine. Disengage the spark plug wire. When tines have stopped, remove foreign objects and check for damage.

CULTIVATING TIPS

If you plan to use your tiller for cultivating:

- Plant rows on 20" - 22" centers for ease of turning.
- Set the depth regulator lever with the detent pin in one of the higher holes. This will allow for shallow cultivation necessary to turn over weeds, and break up and aerate the soil.

MAINTENANCE AND STORAGE

MAINTENANCE

Keeping the tiller in top running condition will prolong the tiller's life, and help it obtain optimum performance whenever you wish to till your garden.

To help you properly care for the rototiller, the following pages include a maintenance schedule, routine inspection procedures, and simple maintenance procedures using basic hand tools. Other service tasks that are more difficult, or require special tools, are best handled by professionals and are normally performed by a qualified mechanic.

- Good maintenance is your responsibility; poor maintenance is an invitation to trouble.

Follow good shop practices.

Keep service area clean and dry.

Be sure electrical outlets and tools are properly grounded.

Use adequate light for the job at hand.

- Make sure the engine is off before you begin any maintenance or repairs. This will eliminate several potential hazards:

Carbon monoxide poisoning from engine exhaust.

Be sure there is adequate ventilation whenever you operate the engine.

Never operate the engine in a closed building.

Burns from hot parts.

Let the engine and exhaust system cool before touching.

Injury from moving parts.

Do not run the engine unless instructed to do so.

- Read the instructions before you begin, and make sure you have the tools and skills required.
- To reduce the possibility of fire or explosion, be careful when working around gasoline.

Use only a non-flammable solvent, not gasoline, to clean parts. Keep cigarettes, sparks and flames away from all fuel-related parts.

- Always use personal protection devices such as eye, hand and hearing protectors when performing any service or maintenance.
- Frequently check tiller tines. They should be free of nicks and cracks and securely fastened in place.
- Periodically tighten all bolts, nuts, screws, and check that all pins are properly installed to make certain unit is safe to operate.
- When completing maintenance or service, make sure all safety guards and devices are installed before using the rototiller.
- Where replacement parts are necessary for periodic maintenance and servicing, use only new, original replacement parts or their equivalents for repair and replacement to restore your equipment to original specifications.
- The manufacturer and/or distributor will not be responsible for injuries or damages caused by use of unapproved parts and/or accessories.
- A first aid kit should be kept readily accessible while performing maintenance on this equipment.

MAINTENANCE SCHEDULE

Your rototiller has been designed and produced by the industry's leading manufacturer of outdoor power equipment to provide you with years of reliable operation.

Keeping your tiller in top running condition will prolong its life, and help you obtain optimum performance.

Please read this normal care schedule, and note the recommended care operating intervals to extend the life of your unit.

| Maintenance Operation | | Each Use | First Month or 20 Hours | Every 3months or 50Hours | Every 6months or 100Hours | Every year or 300Hours |
|----------------------------|-------------|----------|-------------------------|--------------------------|---------------------------|------------------------|
| Drive Belt Tension | Check | √ | | | | |
| | Change | √ | | | | |
| Engine oil | Check level | √ | | | | |
| | Change | | √ | | √ | |
| Air filter | Check | √ | | | | |
| | Clean | | | √(1) | √(1) | |
| | Replace | | | | | √ |
| Tiller Transmission Grease | Check | √ | | | | |
| | Replace | | | √ | | |
| Tire Pressure | Check | √ | | | | |
| Tine Shaft | Clean | √ | | | | |
| Wheel Axle Shaft | Lubricate | | | √ | | |

Service more frequently when used in dusty areas.

SERVICING THE ROTOTILLER

The following information will help you make the necessary checks and perform the procedures required to follow the normal care recommendations made for your rototiller unit. If you prefer, your local authorized dealer can make these checks and perform the required procedures for you.

CHANGE FORWARD/REVERSE BELT

1. Turn off engine. Engine must be cool.
 2. Remove spark plug wire and secure from spark plug.
 3. Remove belt guard.
- Remove the forward belt from the forward engine pulley:
 - Gently pull the engine recoil rope to rotate the pulley.
 - With the pulley turning, force the forward belt out of the V-groove.
 - Slide the belt free of the engine pulley.
 - Pull the forward belt down and out of the way.
 - Remove the reverse belt from the reverse engine pulley:
 - Gently pull the engine recoil rope to rotate the pulley.
 - With the pulley turning, force the reverse belt out of the V-groove.
 - Slide the belt free of engine pulleys and reverse belt guides.
 - Pull belt down and away from transmission pulley.
 - Install new reverse belt:
 - Thread belt up from bottom.
 - Place belt around transmission pulley in groove.
 - Place belt under reverse belt guides.
 - Gently pull engine recoil rope while forcing the belt over the edge of the engine pulley into the V-groove.

⚠ CAUTION

Do not operate tiller before reading the engine manual provided in the parts packet

⚠ WARNING

Temperature of muffler and nearby areas may exceed 150° F, avoid these areas

⚠ IMPORTANT

Engine can overheat and become damaged if debris blocks the cooling system or rotating screen. Never run engine without complete air cleaner installed on engine

- Install new forward belt:
 - Place forward belt in transmission pulley groove.
 - Gently pull the engine recoil rope to rotate the pulley while forcing the forward belt into the V-groove.
4. Replace belt guard.
 5. Attach spark plug wire.

ENGINE MAINTENANCE

Refer to the engine manual included in your parts packet for information on engine maintenance. Your engine manual provides detailed information and a maintenance schedule for performing the following tasks:

1. Check oil level before each use or after every 8 hours of operation.
2. Change oil after first 5-8 hours of operation. change oil while engine is warm. Refill with new oil of recommended grade.
3. Check spark plug yearly or every 100 hours of operation.
4. Service air cleaner.

⚠ WARNING

To prevent accidental starting:

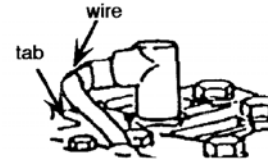

Engine must be turned off and cool, and spark plug wire must be removed and secured from spark plug before checking and adjusting engine or equipment.

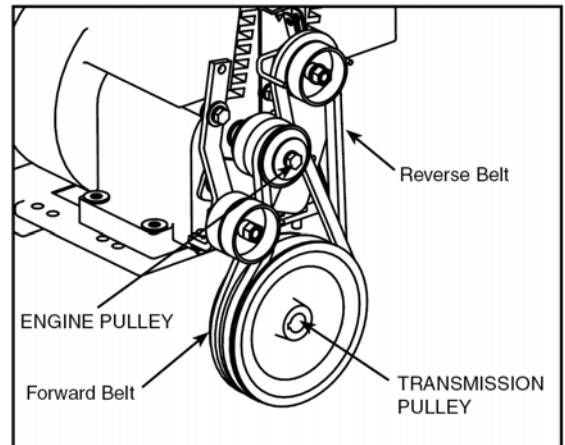

5. Keep engine and parts clean.
6. Check engine and equipment often for loose nuts and bolts, keep these items tightened.

CHECK OR FILL ENGINE CRANKCASE

1. Add oil according to engine manual. Do not overfill. Use a clean, high quality detergent oil. Do not mix oil with gasoline.
Oil level must be full. check the oil level by removing oil fill plug. Oil level should be up to the bottom of the fill plug opening.
2. Always check oil level before starting engine. Refer to engine manual for capacity and type of oil to use.

⚠ IMPORTANT

ENGINE SHIPPED FROM FACTORY WITHOUT OIL. YOU MUST ADD ENGINE OIL BEFORE STARTING ENGINE

CHECK TILLER TRANSMISSION GREASE

⚠ IMPORTANT

TILLER TRANSMISSION SHIPPED FROM FACTORY WITH THE PROPER AMOUNT OF LIQUID GREASE. WHEN REPLACING GREASE, THE TILLER TRANSMISSION HOLDS 18-22 OUNCES. DO NOT OVERFILL

Check the grease level annually. To check the grease level:

1. Move tiller to level ground.
2. Remove grease level dipstick located between the handlebar mounts on the engine mount. If the grease level couldn't touch the dipstick, pls fill the grease.
3. Replace grease level dipstick in the filler hole.
4. Note that the front wheel transmission and rear tine transmission are one common reservoir. When you add to the front transmission, you must wait a short period of time for the grease to flow rearward and equalize in both front and rear. The dipstick will read correctly on level ground for both gear units.

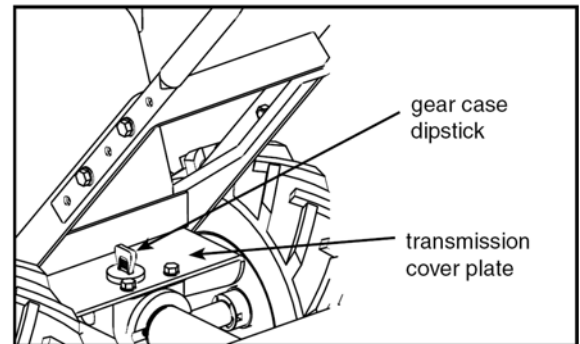

CHECK TIRE PRESSURE

Recommended tire pressure is 20 PSI. If tires do not have equal pressure, tiller will pull to one side.

LUBRICATION

Proper lubrication of moving mechanical parts is critical for proper care and maintenance. Oil the moving parts shown at 10 hour intervals using a 30 weight oil.

CLEAN TINE AXLE SHAFT

1. Turn off engine. Engine must be cool.
2. Remove spark plug wire and secure from spark plug.
3. Tip the tiller forward. Block the tiller in position so that it rests on the engine mount and the tines are exposed.
4. Remove all vegetation, string, wire, and other material that may have accumulated on the axle between the inside set of tines and the seal on the transmission housing.
5. Tip the tiller back to a level position.
6. Replace spark plug wire.

STORAGE

PREPARE FOR STORAGE

Follow the steps below to prepare your tiller for storage. Read your engine manual for detailed instructions on preparing the engine for storage.

1. Protect wheels and axles from rust:
 - Remove lock pin and slide wheel off hub.
 - Coat the axles lightly with axle grease.
 - Slide wheel back on hub and insert lock pin.
2. Drain fuel system completely following engine manufacturer's instructions or add fuel stabilizer to prevent fuel from gumming up during extended storage period.
3. While engine is still warm, drain the oil from the engine. Refill with fresh oil of the recommended grade.
4. Clean external surfaces, engine and cooling fan.
5. Remove spark plug, pour one ounce of SAE 30 oil into spark plug hole.
6. Plug hole and pull starter cord slowly to distribute oil evenly in cylinder head area.
7. Reinstall spark plug.
8. Transport unit to a suitable storage location. If you have chosen to use a fuel stabilizer and have not drained the fuel system, follow all safety instructions storage precautions in this manual to prevent the possibility of fire from the ignition of gasoline fumes. Remember, gasoline fumes can travel to distant sources of ignition and ignite, causing risk of explosion and fire.
9. If there is any possibility of unauthorized use or tampering, remove the spark plug and store it in a safe place before storing the rototiller unit. Be sure to plug the spark plug hole to prevent foreign material from entering.

WARNING

DO NOT STORE TILLER IN AN UNVENTILATED AREA WHERE FUEL FUMES MAY REACH FLAME, SPARKS, PILOT LIGHTS OR AN IGNITED OBJECT. DRAIN FUEL OUTDOORS AWAY FROM ANY IGNITION SOURCES. USE ONLY APPROVED FUEL CONTAINERS

TROUBLESHOOTING AND REPAIR

TROUBLESHOOTING GUIDE

While normal care and routine maintenance will extend the life of your rototiller, prolonged or constant use may eventually require that service be performed to allow it to continue operating properly. The troubleshooting guide below lists the most common problems, causes and remedies

| PROBLEM | REMEDATION |
|--|---|
| Engine will not start | <ul style="list-style-type: none">• Add gas to gas tank.• Connect spark plug wire to spark plug• Throttle must be positioned at choke for a cold start |
| Engine runs rough, foods during operation | <ul style="list-style-type: none">• Clean or replace air cleaner |
| Engine is hard to start | <ul style="list-style-type: none">• Drain old fuel and replace with fresh. Use gas stabilizer at end of season• Make sure spark plug wire is securely attached to spark plug• Drive safety control levers must be released to neutral position to start the engine |
| Engine misses or lacks power | <ul style="list-style-type: none">• Raise the tines for shallow tilling by lowering the depth regulator lever• Remove and clean fuel tank• Clean or replace air cleaner• Improper carburetor adjustment, take to authorized engine service center• Replace spark plug and adjust gap• Drain and refill gas tank and carburetor |
| Engine will not stop when throttle control is positioned at stop Tiller moves forward during starting | <ul style="list-style-type: none">• See engine manual to check and adjust throttle linkage• Drive safety control levers must be released to neutral position to start the engine` |
| Tiller is difficult to control when tilling (machine jumps or lurches forward) | <ul style="list-style-type: none">• Lock wheels in tilling position• Raise the tines for shallower tilling by lowering the depth regulator lever |

| PROBLEM | REMEDATION |
|---|--|
| Tines turn, wheels do not turn | <ul style="list-style-type: none"> • Lock wheels in tilling position • Internal transmission failure, see your dealer |
| Tines turn, wheels turn, tiller does not move | <ul style="list-style-type: none"> • Lower the tines for deeper tilling by raising the depth regulator lever |
| Belts squeal in neutral and/or reverse Belts squeal in forward operation Excessive heat build up in transmission/tine area during tilling | <ul style="list-style-type: none"> • Adjust forward belt guide: <ul style="list-style-type: none"> • Turn engine off and allow muffler to cool • Disconnect spark plug wire and secure from spark plug • Remove belt guard • Pull down on drive safety control levers • Manually bend forward belt guide so there is 1/16 inch or less clearance between belt guide and belt • Replace belt guard and spark plug wire • Adjust tabs on the reverse belt guide <ul style="list-style-type: none"> • Turn engine off and allow muffler to cool • Disconnect spark plug wire and secure from spark plug • Release drive safety control levers to neutral position • Remove belt guard • Adjust tabs of reverse belt guide: <ul style="list-style-type: none"> • While drive safety control levers are released, bend metal tabs on reverse belt guide to 1/64 inch or less clearance from reverse belt • Replace belt guard and spark plug wire • Remove vegetation by following instructions in clean Tine Axle Shaft of Normal care section. FOLLOW ALL SAFETY INSTRUCTIONS • Check transmission fluid and fill if needed |

| TECHNICAL DIAGRAM | |
|-------------------|-------------------|
| Tilling Scope | 480mm |
| Tilling Depth | 175-350mm |
| Gear Shifting | 0, 1, -1 |
| Engine Type | OHV 4-stroke |
| Starting System | Recoil |
| Displacement | 196cc |
| Max Output | 6.5HP/3600rpm |
| Engine Speed | 3600rpm |
| Fuel Volume | 3.6 L |
| Oil Volume | 0.6 L |
| Fuel Type | Unleaded Gasoline |

EXPLODED VIEW & PARTS LIST

CLUTCH & HANDLE

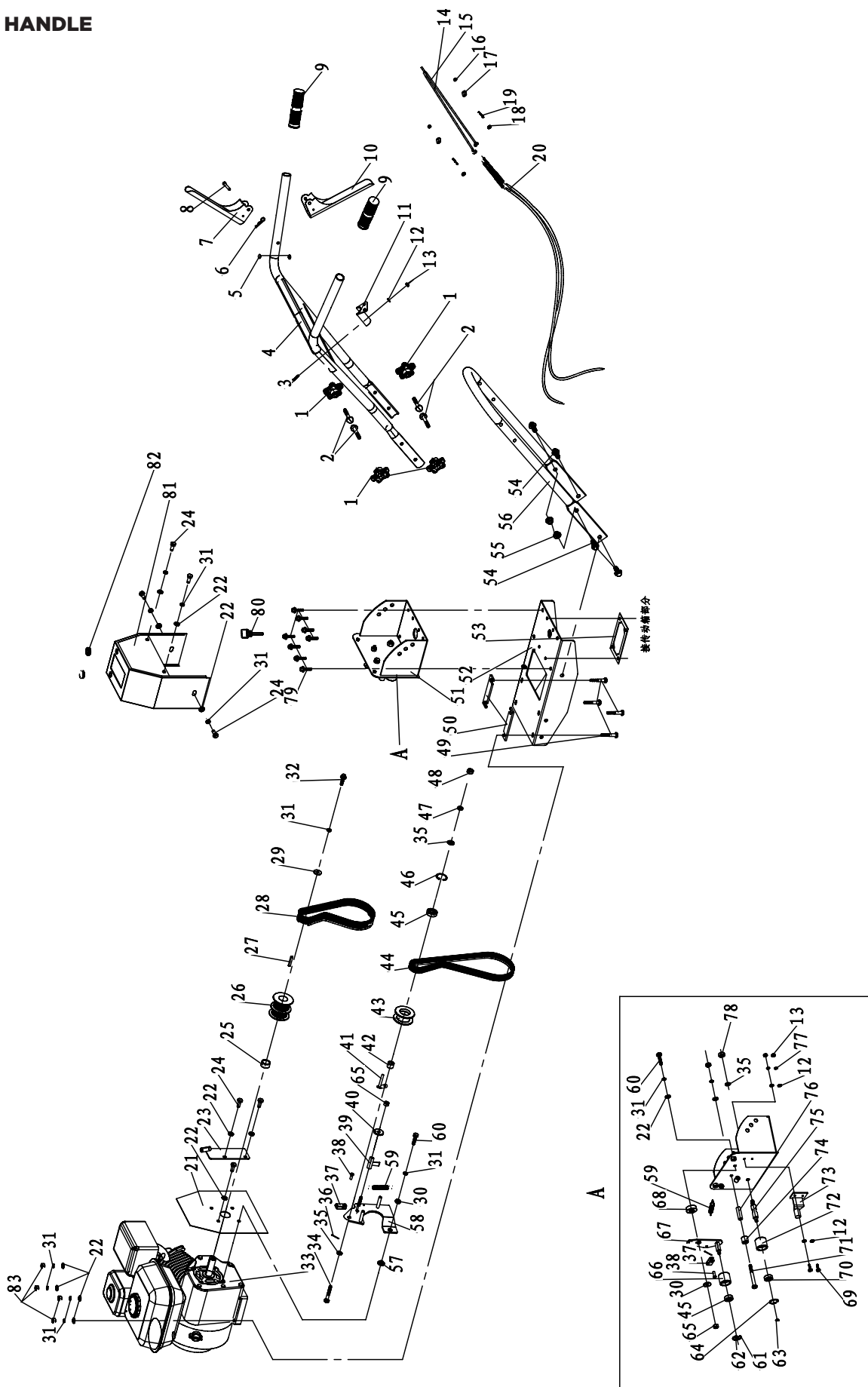

BLADE SKIRTS & SAFETY GUARDS

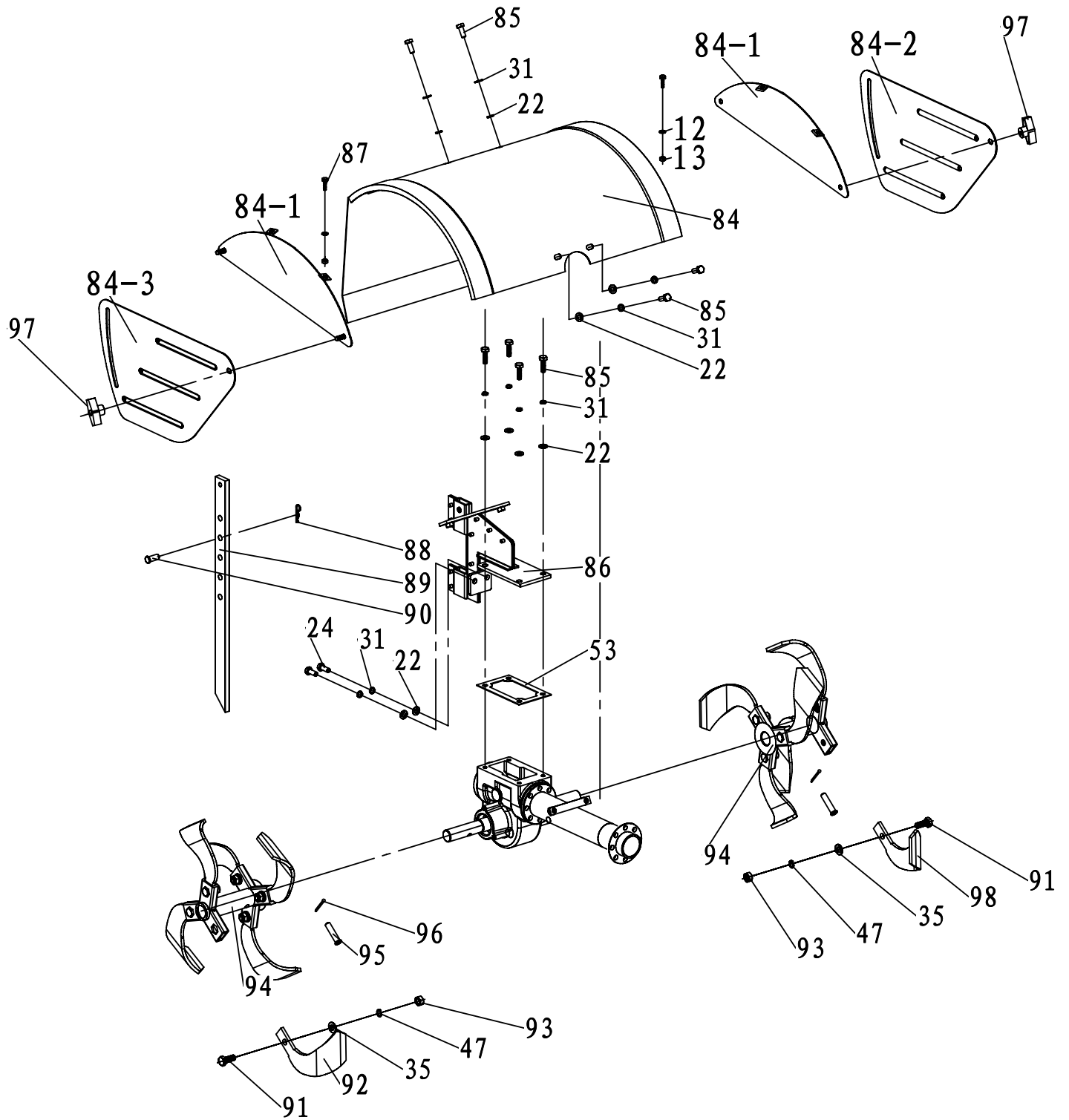

DRIVER PARTS

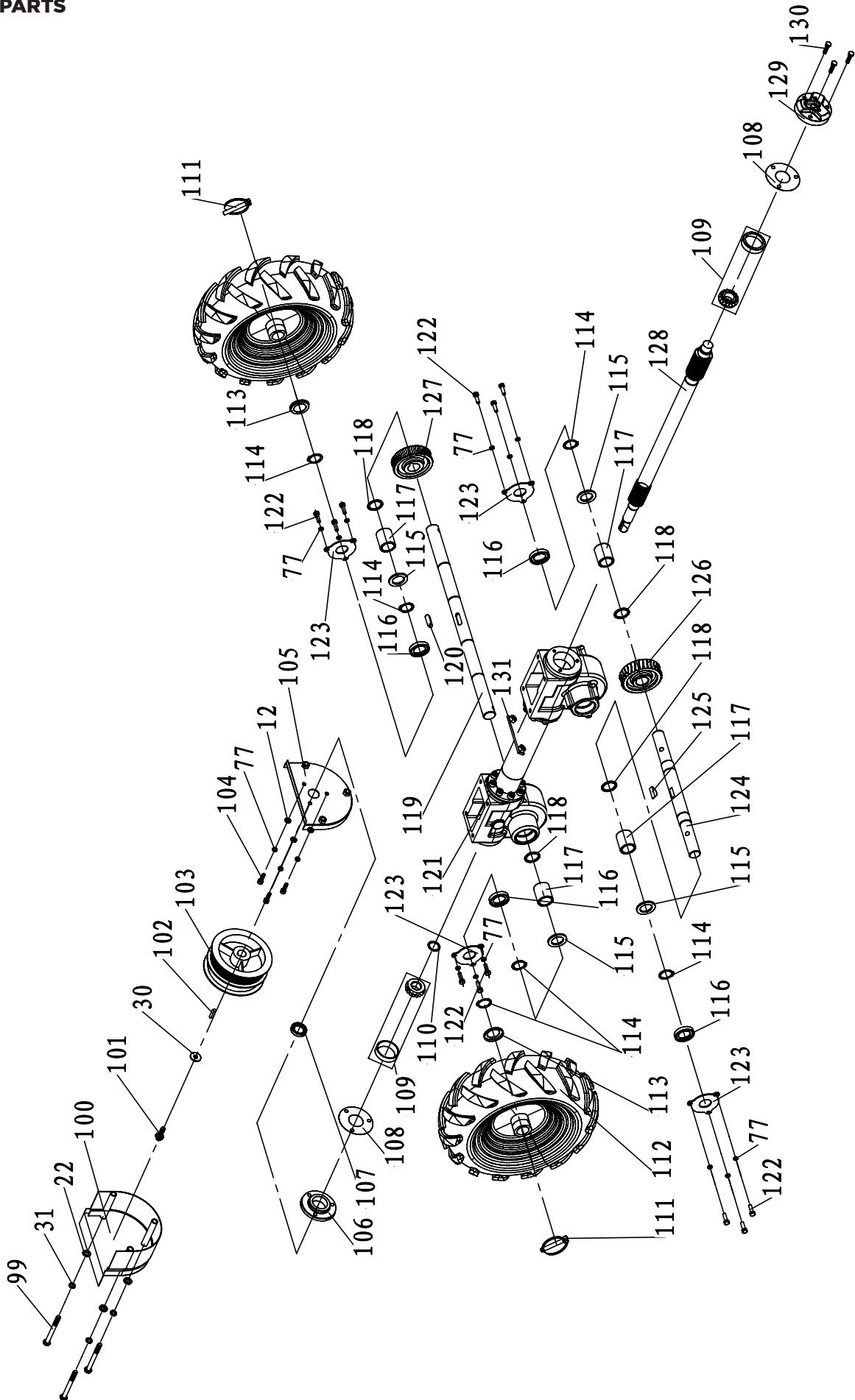

| REF | PART NUM | DESCRIPTION | QTY |
|-----|--------------|-------------------------------------|-----|
| 1 | 102.108C.001 | Handle bar knob nut | 4 |
| 2 | 102.108C.002 | Fan-shaped screw | 4 |
| 3 | 102.108C.003 | Outer Hexagon flange Bolt M6x40 | 1 |
| 4 | 102.108C.004 | Handle bar assembly | 1 |
| 5 | 102.108C.005 | Clutch handle shock absorber rubber | 1 |
| 6 | 102.108C.006 | B type pin 1.5x37 | 1 |
| 7 | 102.108C.007 | Forward clutch handle | 1 |
| 8 | 102.108C.008 | Pin Ø6X45 | 1 |
| 9 | 102.108C.009 | Handle cover | 2 |
| 10 | 102.108C.010 | Reverse clutch handle | 1 |
| 11 | 102.108C.011 | Cable fixing plate | 1 |
| 12 | 102.108C.012 | Flat washer 6 | 9 |
| 13 | 102.108C.013 | Locknut M6 | 7 |
| 14 | 102.108C.014 | Forward clutch lever | 1 |
| 15 | 102.108C.015 | Reverse clutch lever | 1 |
| 16 | 102.108C.016 | Locknut M5 | 2 |
| 17 | 102.108C.017 | Pull pole protector | 2 |
| 18 | 102.108C.018 | Flat washer 5 | 2 |
| 19 | 102.108C.019 | Spring | 2 |
| 20 | 102.108C.020 | Clutch cable assembly | 2 |
| 21 | 102.108C.021 | Big belt cover protector | 1 |
| 22 | 102.108C.022 | Flat washer | 41 |
| 23 | 102.108C.023 | The pull plate assembly | 1 |
| 24 | 102.108C.024 | Outer Hexagon Bolt M8X20 | 9 |
| 25 | 102.108C.025 | Small belt wheel shaft bushing | 1 |
| 26 | 102.108C.026 | Small belt wheel | 1 |
| 27 | 102.108C.027 | Flat key 4.78X5X35 | 1 |
| 28 | 102.108C.028 | Forward belt 7PK612 | 1 |
| 29 | 102.108C.029 | Flat washer Ø8XØ22X2 | 2 |
| 30 | 102.108C.030 | Flat washer Ø8XØ22X2 | 2 |
| 31 | 102.108C.031 | Spring washer 8 | 26 |
| 32 | 102.108C.032 | Outer Hexagon Bolt | 1 |
| 33 | 85.570.070 | Gasoline engine - PowerEASE | 1 |
| 33 | 85.510.067 | Gasoline engine - HONDA | |
| 34 | 102.108C.034 | Outer Hexagon Bolt M10X50 | 1 |
| 35 | 102.108C.035 | Flat washer 10 | 14 |
| 36 | 102.108C.036 | Pin Ø1.5X20 | 2 |
| 37 | 102.108C.037 | Cable clip | 2 |
| 38 | 102.108C.038 | Pin Ø6X16 | 2 |
| 39 | 102.108C.039 | Shaft bushing 1 | 1 |
| 40 | 102.108C.040 | Flat washer Ø8XØ28X3 | 1 |
| 41 | 102.108C.041 | Belt buckle | 1 |

| REF | PART NUM | DESCRIPTION | QTY |
|-----|--------------|----------------------------------|-----|
| 42 | 102.108C.042 | Axle sleeve | 1 |
| 43 | 102.108C.043 | Reverse tension wheel | 1 |
| 44 | 102.108C.044 | Reverse belt 5PK740 | 1 |
| 45 | 102.108C.045 | Deep groove ball bearing 6200 | 3 |
| 46 | 102.108C.046 | Circlip 30 | 1 |
| 47 | 102.108C.047 | Spring washer 10 | 13 |
| 48 | 102.108C.048 | Outer Hexagon Nut M10 | 1 |
| 49 | 102.108C.049 | Outer Hexagon Bolt M8X45 | 4 |
| 50 | 102.108C.050 | Ajustable plate | 2 |
| 51 | 102.108C.051 | Handle seat assembly | 1 |
| 52 | 102.108C.052 | Engine seat assembly | 1 |
| 53 | 102.108C.053 | Gaskets | 2 |
| 54 | 102.108C.054 | Outer Hexagon flange Bolt M10x25 | 4 |
| 55 | 102.108C.055 | Outer Hexagon Nut M10 | 2 |
| 56 | 102.108C.056 | Handle arm | 1 |
| 57 | 102.108C.057 | Axle sleeve | 1 |
| 58 | 102.108C.058 | The seat board | 1 |
| 59 | 102.108C.059 | Spring | 2 |
| 60 | 102.108C.060 | Outer Hexagon Bolt M8X30 | 2 |
| 61 | 102.108C.061 | Circlip 30 | 1 |
| 62 | 102.108C.062 | Circlip 10 | 1 |
| 63 | 102.108C.063 | Circlip 8 | 1 |
| 64 | 102.108C.064 | Circlip 24 | 1 |
| 65 | 102.108C.065 | Locknut M8 | 4 |
| 66 | 102.108C.066 | Forward tension wheel | 1 |
| 67 | 102.108C.067 | Clutch arm assembly | 1 |
| 68 | 102.108C.068 | Tension bushing | 1 |
| 69 | 102.108C.069 | Outer Hexagon Bolt M6X16 | 2 |
| 70 | 102.108C.070 | Deep groove ball bearings 628 | 4 |
| 71 | 102.108C.071 | Outer Hexagon Bolt M8X70 | 1 |
| 72 | 102.108C.072 | Forward tension wheel 1 | 1 |
| 73 | 102.108C.073 | Retaining stem components belt | 1 |
| 74 | 102.108C.074 | Belt block set 1 | 1 |
| 75 | 102.108C.075 | Tension wheel pole | 1 |
| 76 | 102.108C.076 | Belt block set 2 | 1 |
| 77 | 102.108C.077 | Spring washer 6 | 5 |
| 78 | 102.108C.078 | Locknut M10 | 1 |
| 79 | 102.108C.079 | Outer Hexagon flange Bolt M8x25 | 8 |
| 80 | 102.108C.080 | Oil dipstick | 1 |

| REF | PART NUM | DESCRIPTION | QTY |
|------|--------------|-------------------------------------|-----|
| 81 | 102.108C.081 | Big belt cover protector | 1 |
| 82 | 102.108C.082 | Cable protector | 2 |
| 83 | 102.108C.083 | Outer Hexagon Nut M8 | 4 |
| 84 | 102.108C.084 | Safety guard assembly | 1 |
| 84-1 | 102.108C.085 | Right cover | 2 |
| 84-2 | 102.108C.086 | Left connecting plate | 1 |
| 84-3 | 102.108C.087 | Right connecting plate | 1 |
| 85 | 102.108C.088 | Outer Hexagon Bolt M8X25 | 16 |
| 86 | 102.108C.089 | Depth Regulator seat assembly | 1 |
| 87 | 102.108C.090 | Outer Hexagon flange Bolt M6x20 | 4 |
| 88 | 102.108C.091 | B type pin 2x37 | 1 |
| 89 | 102.108C.092 | Safety guard | 1 |
| 90 | 102.108C.093 | Pin Ø10X25 | 2 |
| 91 | 102.108C.094 | Outer Hexagon Bolt M10X1x25 | 2 |
| 92 | 102.108C.095 | Left blade components | 6 |
| 93 | 102.108C.096 | Outer Hexagon Nut M10X1 | 12 |
| 94 | 102.108C.097 | blade components | 2 |
| 95 | 102.108C.098 | Pin Ø10X42 | 2 |
| 96 | 102.108C.099 | Cotter pin 2x37 | 2 |
| 97 | 102.108C.100 | Knob nut | 4 |
| 98 | 102.108C.101 | Right tillage blade | 6 |
| 99 | 102.108C.102 | Outer Hexagon Bolt M8X90 | 3 |
| 100 | 102.108C.103 | Small belt cover assembly | 1 |
| 101 | 102.108C.104 | Outer Hexagon flange Bolt M8x20 | 1 |
| 102 | 102.108C.105 | Flat key 5X5X25 | 1 |
| 103 | 102.108C.106 | Big belt wheel | 1 |
| 104 | 102.108C.107 | Inner Hexagon Bolt M6X20 | 3 |
| 105 | 102.108C.108 | Small belt cover protector assembly | 1 |
| 106 | 102.108C.109 | Front cover | 1 |
| 107 | 102.108C.110 | Framework oil seal Ø20XØ32X6 | 1 |
| 108 | 102.108C.111 | Gaskets 1 | 2 |
| 109 | 102.108C.112 | Cone needle bearing 7204E | 2 |
| 110 | 102.108C.113 | washer | 1 |
| 111 | 102.108C.114 | lock pin | 2 |
| 112 | 102.108C.115 | Wheel 13inch | 2 |
| 113 | 102.108C.116 | Wheel shaft cap | 2 |
| 114 | 102.108C.117 | Circlip 25 | 6 |
| 115 | 102.108C.118 | Washer | 4 |
| 116 | 102.108C.119 | Framework oil seal Ø25XØ40X7 | 4 |

| REF | PART NUM | DESCRIPTION | QTY |
|-----|--------------|---------------------------------|-----|
| 117 | 102.108C.120 | Output shaft bearing | 4 |
| 118 | 102.108C.121 | Ajustable washer | 4 |
| 119 | 102.108C.122 | Wheel shaft | 1 |
| 120 | 102.108C.123 | Flat key | 1 |
| 121 | 102.108C.124 | Cabinet assembly | 1 |
| 122 | 102.108C.125 | Outer Hexagon flange Bolt M6x12 | 6 |
| 123 | 102.108C.126 | Oil seal cap | 4 |
| 124 | 102.108C.127 | Tiller shaft | 1 |
| 125 | 102.108C.128 | Semicircle key | 1 |
| 126 | 102.108C.129 | Tiller worm wheel | 1 |
| 127 | 102.108C.130 | Worm wheel | 1 |
| 128 | 102.108C.131 | Worm wheel shaft | 1 |
| 129 | 102.108C.132 | Rear cap | 1 |
| 130 | 102.108C.133 | Outer Hexagon Bolt M6X25 | 3 |
| 131 | 102.108C.134 | Top cover plate | 1 |



BRABEREQ.COM
WGSALES@BRABEREQ.COM

PHONE: 604-850-7770
FAX: 604-850-7774
TOLL FREE PHONE: 1-877-588-3311
TOLL FREE FAX: 1-800-665-7334