

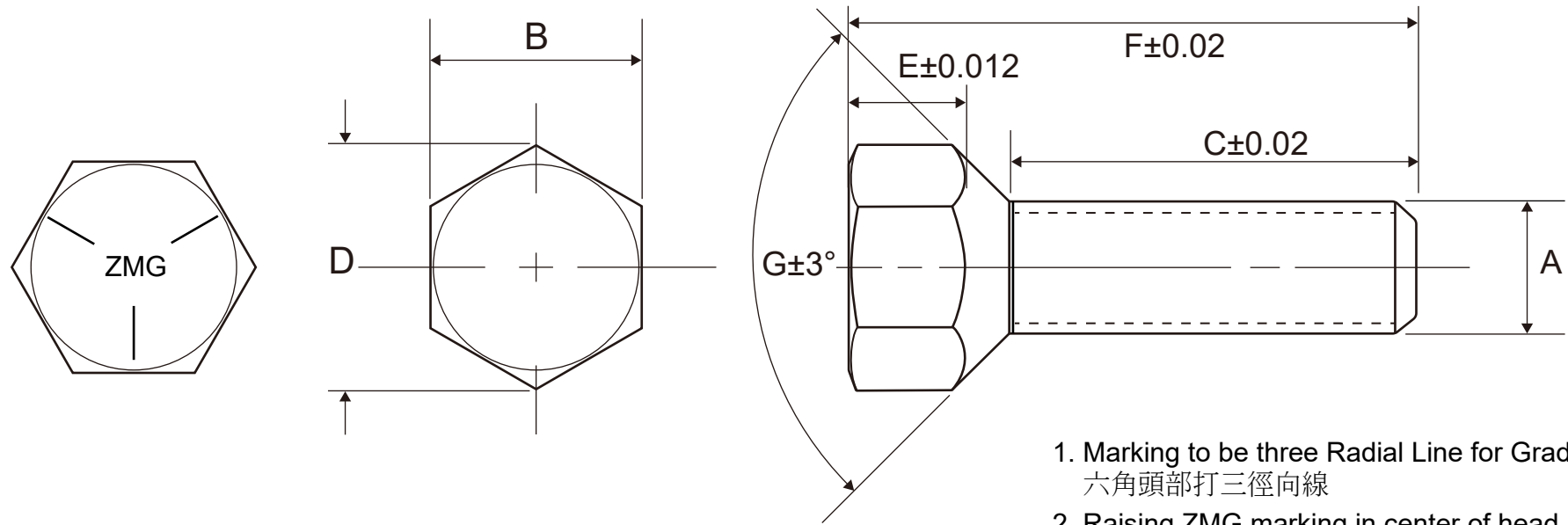

REV	DESCRIPTION	DATE	APPROVED
-	INITIAL RELEASE	05.22.2025	
1	MODIFICATION TO DIMENSION	10.28.2025	

ZMG PT No	A DIAMETER		B Width AF		C THREAD LENGTH			D Width AC		E Hex Head Height			F Overall Length			G Bearing Angle		SURFACE
	DIA.	THREAD	MIN.	MAX.	MIN.	NOMINAL	MAX.	MIN.	MAX.	MIN.	NOMINAL	MAX.	MIN.	NOMINAL	MAX.	MIN.	MAX.	
3456698	1/2 (0.500)	20	0.8000	0.8125	0.980	1.000	1.020	0.9250	0.9375	0.3346	0.3466	0.3586	1.4567	1.4767	1.4967	87	93	ZP CR3
3456699	1/2 (0.500)	20	0.7380	0.7500	1.480	1.500	1.520	0.8400	0.8660	0.3543	0.3663	0.3783	1.9800	2.0000	2.0200	87	93	ZP CR3
3456700	9/16 (0.562)	18	0.8630	0.8750	1.105	1.125	1.145	0.9880	1.0000	0.3661	0.3781	0.3901	1.6050	1.6250	1.6450	87	93	ZP CR3
3456701	9/16 (0.562)	18	0.8630	0.8750	1.480	1.500	1.520	0.9880	1.0000	0.4803	0.4923	0.5043	2.1050	2.1250	2.1450	87	93	ZP CR3
3456702	9/16 (0.562)	18	0.8630	0.8750	1.980	2.000	2.020	0.9880	1.0000	0.4213	0.4333	0.4453	2.5420	2.5620	2.5820	87	93	ZP CR3
3456703	5/8 (0.625)	18	0.9255	0.9375	1.355	1.375	1.395	1.0630	1.0770	0.4880	0.5000	0.5120	1.9800	2.0000	2.0200	87	93	Black Phosphate
3456704	5/8 (0.625)	18	0.8630	0.8750	2.417	2.437	2.457	0.9880	1.0000	0.4998	0.5118	0.5238	3.0420	3.0620	3.0820	87	93	ZP CR3



1. Marking to be three Radial Line for Grade 5
六角頭部打三徑向線
2. Raising ZMG marking in center of head
頭部中心須打ZMG浮印

INTERPRET GEOMETRIC TOLERANCING DIMENSIONS ARE IN INCHES DECIMAL TOLERANCES: LINEAR DIMENSIONS: ANGULAR DIMENSIONS: DRILLED HOLES: DO NOT SCALE DRAWING	DRAWING No.		 SHC HARDWARE LTD TEL:886-7-6261296 FAX:886-7-6264833 www.shchd.com.tw	
	APPROVALS	DATE		
	DRAWN BY JL	2025.5.22	DRAWING TITLE	MATERIAL
	CHECKED BY		HEX WHEEL BOLT	C10B21 SAE J429 GRADE 5
APPROVED BY		SURFACE		
		SCALE 2:1	SHEET 1 OF 1	