

Product datasheet

Captair 481

Ductless filtering fume hood

Safer to operate

- Erlab's advanced carbon filtration technology and/or HEPA/ULPA accommodates your specific needs
- Meets AFNOR NF X 15 211/ANSI Z9.5-2012 filtration efficiency standard (class 1 and 2)
- Sensors that detect filter breakthrough of solvents, acids or formaldehyde
- Safety back up filter in case of main filter saturation
- Continuous monitoring of Air face velocity
- Erlab Safety Program: application analysis and validation, usage certification, filter change reminders

Simpler to use

With Smart Technology, you can easily see that the hood is operating safely. Should the light pulse you are notified that:

- Containment has been compromised or,
- The filter has breakthrough or,
- There is a Fan failure

Flexibility

- The configurable filtration column will accommodate application changes
- No ductwork needed. This allows you to move the hood anywhere.

Savings

- No ductwork cost
- Annual energy costs decreases significantly
- Energy savings outweigh filter replacement costs.

Environment

- No dangerous chemicals released into the atmosphere
- Low energy consumption



You get the highest level of filtration performances



Smart Technology keeps you safe

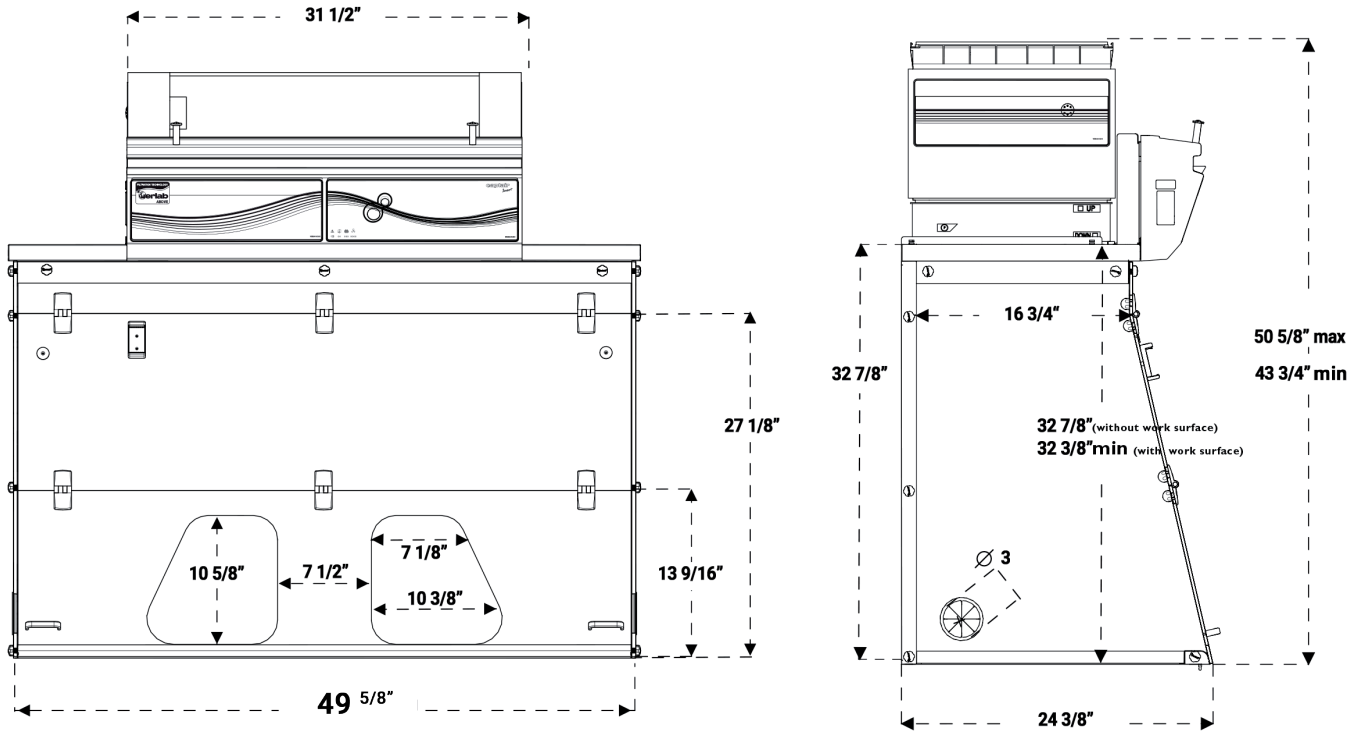

Heights according to the filtration column configuration

Type 1C or 1P	43 7/8"	Please add 5 3/4" between the last filter and the ceiling to allow a good air recirculation and to replace filters easily
Type 2C or 1P1C or 1C1P	47 1/2"	
Type 1P2C or 1P1C1P	79 1/2"	

Work surfaces with built in spill tray

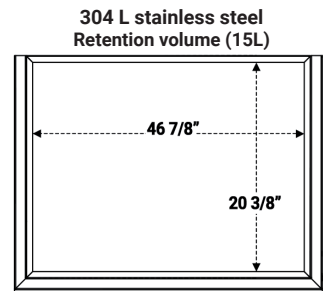
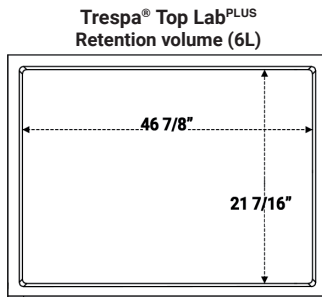
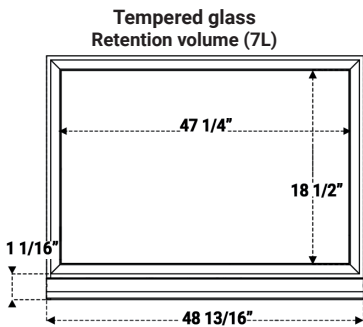

Benchcap: fixed work bench

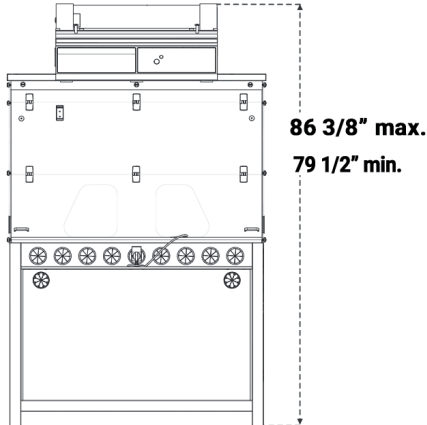

Mobicap : mobile rolling cart

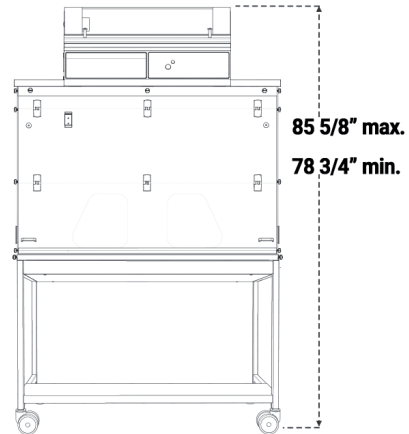



Designed with you in mind: Our filtration column can be configured for your specific application requirements.

Available filters :

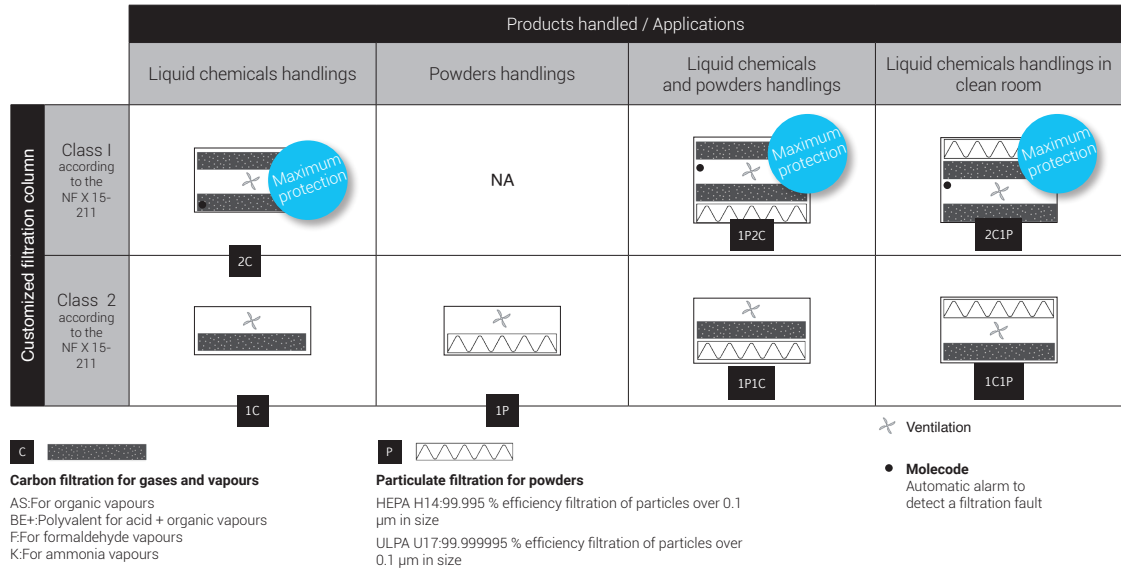

Safety Standards	AFNOR NF X 15-211:2009: France - BS 7989: England DIN 12 927:Germany - EN 1822:1998 (HEPA H14 & ULPA U17 Filters) - CE Marking
Air Flow	220 m3/h - 129 CFM
Air Face Velocity	0.4 to 0.6 m/s - 79 fpm to 118 fpm
Voltage/Frequency	90-220 V / 50-60 Hz
Power consumption	65 W
Sash openings	Oblong
Structure	Corrosion resistant electro-galvanized steel coated with anti-acid polymer
Side and front panels	Chemical resistant acrylic
Filtration module	Polypropylene

Equipment

Communication interface	Simple communication by audible and light pulses: air face velocity, automatic alarm to detect a filtration fault, fan failure alarm
Filtration technology	1 column that can be configured to handle liquids, powders, or both
Carbon filtration for gases and vapours	Following filtration column configuration (see table above)
Particulate filtration for powders	Following filtration column configuration (see table above)
Internal lighting	LED lighting > 650 Lux
Anemometer	Air face velocity alarm
Chemical Listing	List of approved chemicals

Accessories

Work Surfaces	TRESPA® TOPLAB PLUS, Glass
Molecode	Detection sensor for : Type S, for solvents / Type A, for acids / Type F, for formaldehyde
Benches	Mobile (Mobicap) or fixed (Benchcap)
Particulate Pre-filter	Protects the main filter(s) from dust
Transparent Back Panel	Clear acrylic panel for easy viewing



The Erlab Research and Development laboratory

About Erlab

Since 1968, **Erlab** has been a specialist, inventor and world leader in **ductless, zero-emission filtering fume hoods for laboratories** to provide total safety in chemical handling.

1 Erlab filtration

We provide technologies to protect laboratory staff from inhaling chemicals. This is made possible thanks to our Research and Development (R&D) department, which has continuously improved our filtration technology for more than 50 years. That's why, in 2009, we invented the ERLAB ABOVE label for tried and tested filtration technology.

2 The AFNOR NF X 15-211: 2009 standard

Erlab's filtration technology conforms to the NF X 15-211: 2009 standard, the industry's most demanding standard for molecular filtration, developed by a committee of independent scientists and specialized manufacturers.

This text imposes performance criteria linked to:

- Filtration efficiency
- Containment efficiency
- Air face velocity
- Documentation: chemical listing

3 The ESP program

A set of three services included with the purchase of each device designed to ensure your safety.

 **eValiQuest** Risk analysis – Determination of protection needs – Determination of ergonomic needs.

 **ValiPass** Certified installation – Total safety for handling.

 **ValiGuard** Ongoing monitoring – Preventative and maintenance inspections – Device reconfiguration based on protection needs – Development of handling.

4 Flex technology

The combination of molecular and particulate filtration technologies allows a single device to meet laboratories' protection needs. This innovation from Erlab's R&D department offers unprecedented flexibility, versatility and value. A single device can be reconfigured over time and easily reassigned to other applications.

5 Smart technology

Smart technology is a simple and innovative means of communication that improves safety. This technology uses a light and sound signal to indicate the user's level of protection. The advantages of the technology are:

- 1/ Light pulsation: Real-time communication via LED light pulses intuitively alerts the user to the device's operating status.
- 2/ Simplicity: One-touch activation.
- 3/ Detection system: The exclusive detection system continuously monitors filtration performance.
- 4/ Built-in monitoring: This service provides direct access to the status, settings and history of your device.

France
+33 (0) 2 32 09 55 80 | ventes@erlab.net

Germany
0800 330 47 31 | export.north@erlab.net

United States
+1 800-964-4434 | info@erlab.com

United Kingdom
+44 (0) 1722 341 940 | export.north@erlab.net

China
+86 (0) 512 5781 4085 | sales.china@erlab.com.cn

Italy
+39 (0) 2 89 00 771 | export.south@erlab.net

Spain
+34 936 732 474 | export.south@erlab.net

 **erlab** usa.erlab.com
You can breathe. iaq.erlab.com