

- Constructed from 18 Ga. A1011 steel.
- 3 piece post constructed from 14 Ga. A1011 steel.
- Recommended post depth is 2'-0" depending on local soil conditions.
- Trash can has a 10 gallon capacity.
- Bag dispenser is equipped with a lock and key (keyed alike) to prevent theft.
- Triple bag dispenser holds up to 600 bags.
- Non-toxic powder coat finish.
- All assembly hardware included.
- Estimated weight: 38 lbs.

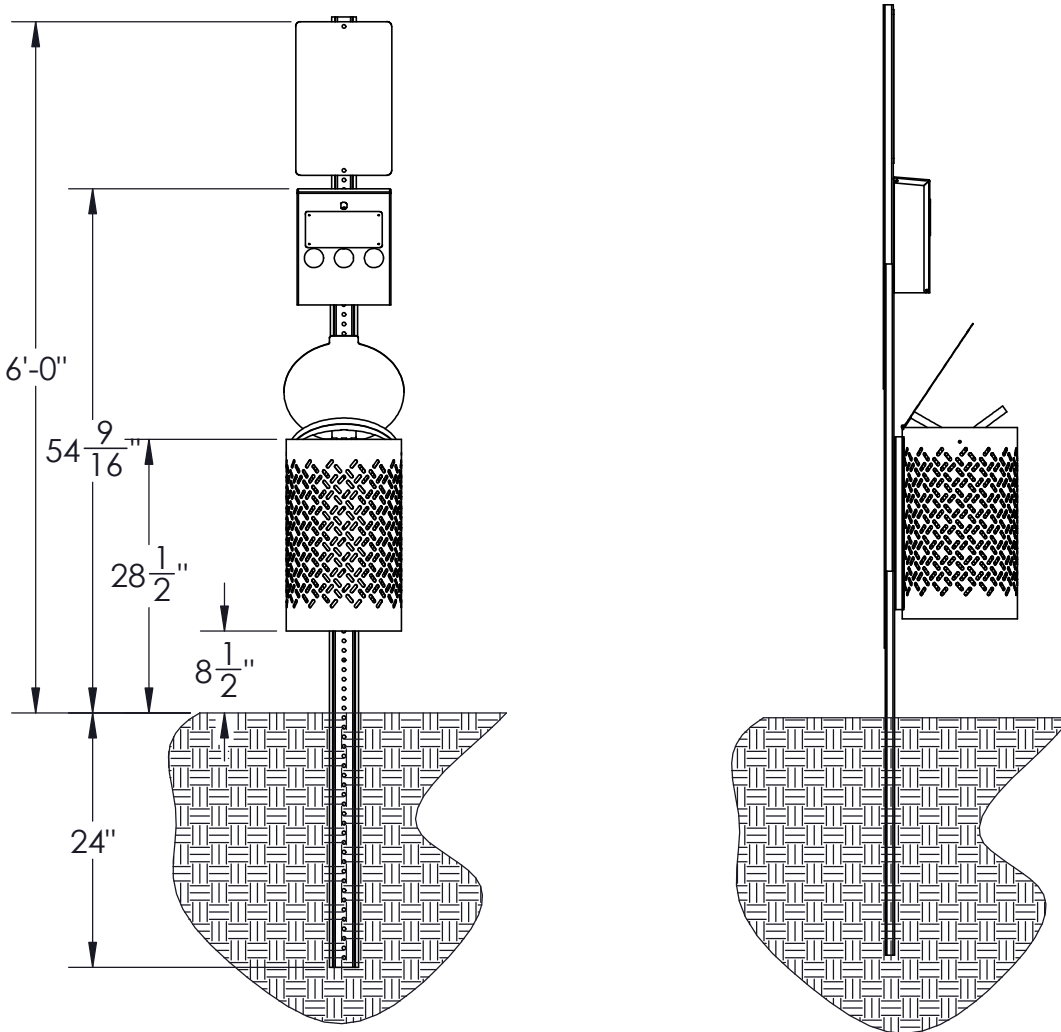
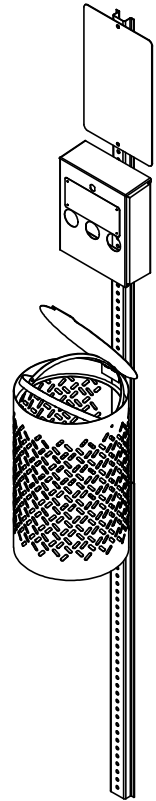

WARNING: MUST BE PERMANENTLY MOUNTED

CUSTOMER APPROVAL :

DATE :

JAMESTOWN
ADVANCED
PRODUCTS
 CORPORATION

THIS DRAWING, WHICH CONTAINS PROPRIETARY INFORMATION, IS THE PROPERTY OF JAMESTOWN ADVANCED PRODUCTS CORPORATION. IT SHALL NOT BE REPRODUCED IN ANY MANNER NOR DISCLOSED TO THIRD PARTIES WITHOUT WRITTEN PERMISSION OF JAMESTOWN ADVANCED PRODUCTS CORPORATION.

DATE : 10/23/25

PRODUCT PART NUMBER : 20905

REV. NO.

PRODUCT DESCRIPTION :

ROUND DOG WASTE CONTAINER

2855 GIRTS ROAD
 JAMESTOWN, NY 14701