



# Standard Parts

Number:	EM-070
Date Issued:	C-NOV02

ELECTRONIC DOCUMENT IN THE VIEWER IS CONTROLLED. PRINTED COPY IS AN UNCONTROLLED DOCUMENT.

## HEX PILOTED PROJECTION WELD NUTS

### GENERAL SPECIFICATIONS

**GENERAL:** There is no National or International Standard on six (6) projection weld nuts as covered by this standard. The specifications are based upon local manufacturer and user requirements. Commercial availability of these six (6) projection weld nuts is generally restricted to North America.

The specification for three (3) projection weld nuts are based on German Institute of Standardization DIN 929. Weld nuts to DIN 929 do not meet proof load requirements calculated for full loadability and therefore they are restricted to applications where local availability and existing tooling and equipment mandates their use.

**PREFERRED PARTS POLICY:** Preferred parts are so designated to reduce variety of parts and assure maximum availability, interchangeability and cost savings in volume buying.

Sizes: 6 Projection Regular Series - M6, M8 and M10  
6 Projection Heavy Series - M10, M12 and M16

**MARKING:** Six-projection weld nuts shall be identified as metric by the symbol "M" or a numerical "9" indented on the top surface of the nut.

**MATERIAL:** Six-projection weld nuts shall be steel, Case MS 352, 1010, 1015, 1018 or 1117.

Three-projection weld nuts shall be steel with a maximum carbon content of 0.25% and a maximum sulfur content of 0.13% that meets the following proof loads:

Size	Proof Load in N	Size	Proof Load in N	Size	Proof Load in N
M3	3,800	M6	15,500	M12	65,300
M4	6,800	M8	28,300	M14	89,700
M5	11,000	M10	44,800	M16	123,000

**THREADS:** Threads shall be standard (coarse) pitch ISO Metric Screw Threads, tolerance class 6G for 3-projection nuts per DIN 929 and class 6H and 6-projection nuts.

**WORKMANSHIP:** Nuts shall be free from burrs, seams, laps, loose scale, irregular surfaces, oxide and any defects that might affect their weldability and/or serviceability.

**PREVAILING TORQUE:** When specified, prevailing torque weld nuts shall be all metal, one-piece construction. The prevailing torque characteristics are developed by controlled distortion of the nut thread and/or body on the upper portion or dome of the nut and are to meet the prevailing torque requirements specified in ANSI B18.16.1M. Prevailing torque weld nuts are listed in section EM-072 and are dimensionally identical to the comparable non-prevailing torque weld nut in section EM-070.

Supersedes Issue:	Dated:	Page:
EM-070	JUL 02	1 of 6

ELECTRONIC DOCUMENT IN THE VIEWER IS CONTROLLED. PRINTED COPY IS AN UNCONTROLLED DOCUMENT.

### HEX PILOTED PROJECTION WELD NUTS

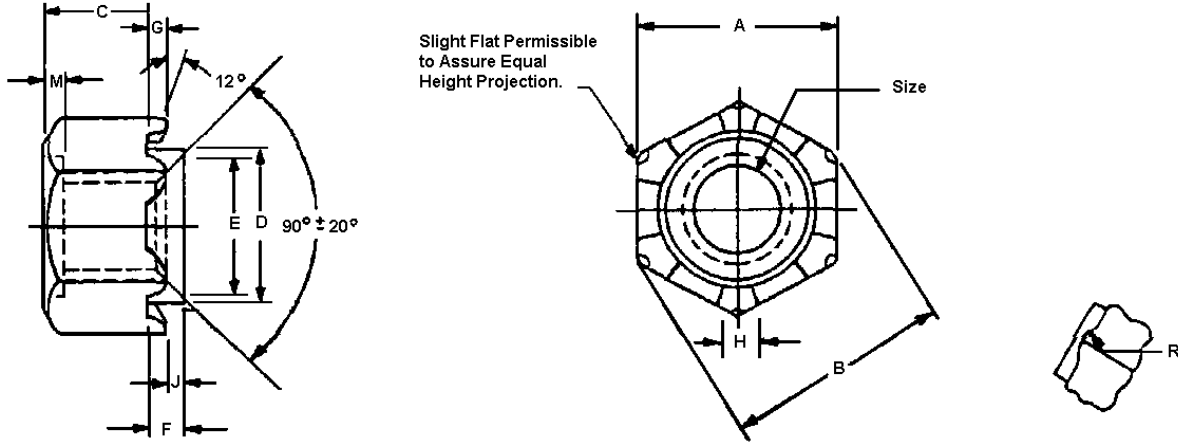

6 PROJECTIONS REGULAR SERIES - SHORT PILOT

Dimensions in millimetres

Nominal Size			M5*	M6	M8	M10	M12*
Pitch, Nominal			0.8	1	1.25	1.5	1.75
A	Width Across Flats	max.	11.0	13	15	18	21
		min.	10.7	12.7	14.7	17.7	20.6
B	Width Across Corners	min.	12.12	14.38	16.64	20.03	23.35
C	Nut Thickness	max.	4.8	5.6	7.1	8.2	9.9
		min.	4.4	5.1	6.6	7.7	9.4
D	Pilot Diameter	max.	7.65	9.1	11.1	13.6	16.1
		min.	7.35	8.8	10.8	13.3	15.8
E	Chamfer Diameter	min.	5.8	6.8	8.8	11	13
F	Pilot Height	max.	1.03	1.13	1.13	1.29	1.39
		min.	0.77	0.87	0.87	1.03	1.13
G	Projection Height	max.	0.47	0.52	0.52	0.63	0.73
		min.	0.31	0.36	0.36	0.47	0.57
H	Projection Width	min.	2.64	3.17	3.69	4.49	5.29
J	Projection Locating Height	ref.	0.30	0.35	0.35	0.40	0.40
R	Projection Radius	nom.	2.87	3.54	4.64	5.4	6.25
	Plate Thickness	max.	1.5	1.6	1.6	1.9	1.9
		min.	1.0	1.1	1.1	1.3	1.4
	Hole Size in Plate	±0.25	8.00	9.50	11.50	14.00	16.50
	Current Case Part No.		830-60005	830-60006	830-60008	830-60010	830-60012
	Replaced IH Part No.		30946R1	30700R1	30701R1	30702R1	30703R1
	New Holland Part No.			86639237	86639238	86639239	86639641

\* Non-Preferred

\*\* For General Specifications See Page 1 \*\*

Supersedes Issue:	Dated:	Page:
EM-070	JUL 02	2 of 6

ELECTRONIC DOCUMENT IN THE VIEWER IS CONTROLLED. PRINTED COPY IS AN UNCONTROLLED DOCUMENT.

## HEX PILOTED PROJECTION WELD NUTS

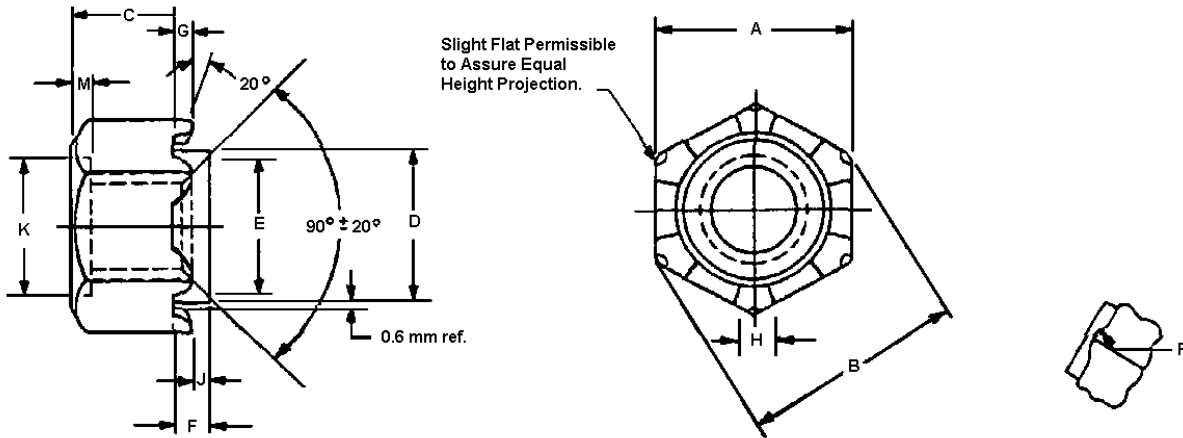

6 PROJECTIONS HEAVY SERIES - SHORT PILOT

Dimensions in millimetres

Nominal Size		M8*	M10	M12	M14*	M16
Pitch, Nominal		1.25	1.5	1.75	2	2
A	Width Across Flats	max. 15 min. 14.7	18 17.7	21 20.6	24 23.6	26 24.9
B	Width Across Corners	min. 16.6	20.0	23.3	26.7	29.1
C	Nut Thickness	max. 9.3 min. 8.8	12.2 11.7	14.3 13.8	16.5 15.9	19 18.4
D	Pilot Diameter	max. 11.1 min. 10.8	13.4 13.1	16.1 15.8	19 18.7	20.5 20.2
E	Chamfer Diameter	min. 8.6	10.7	12.8	15	17
F	Pilot Height	max. 0.83 min. 0.57	1.13 0.87	1.33 1.07	1.33 1.07	1.33 1.07
G	Projection Height	max. 0.53 min. 0.37	0.63 0.47	0.73 0.57	0.73 0.57	0.73 0.57
H	Projection Width	min. 3.69	4.49	5.29	6.09	6.61
J	Projection Locating Height	ref. 0.25	0.45	0.55	0.55	0.55
K	Counterbore Diameter	max. 10.5 min. 10.2	12.8 12.5	15.3 15	18.3 18	19.5 19.2
M	Counterbore Depth	max. 1.5 min. 1.25	1.5 1.25	1.5 1.25	1.5 1.25	1.5 1.25
R	Projection Radius	nom. 4.54	5.4	6.25	8.09	9.41
	Plate Thickness	max. 1.8 min. 0.7	1.8 1	2.2 1.2	2.2 1.2	2.2 1.2
	Hole Size in Plate	max. 11.5 min. 11.2	13.8 13.5	16.5 16.2	19.5 19.2	21 20.7
Current Case Part No.		830-61008	830-61010	830-61012	830-61014	830-61016

\* Non-Preferred

\*\* For General Specifications See Page 1 \*\*

Supersedes Issue:	Dated:	Page:
EM-070	JUL 02	3 of 6

ELECTRONIC DOCUMENT IN THE VIEWER IS CONTROLLED. PRINTED COPY IS AN UNCONTROLLED DOCUMENT.

## HEX PILOTED PROJECTION WELD NUTS

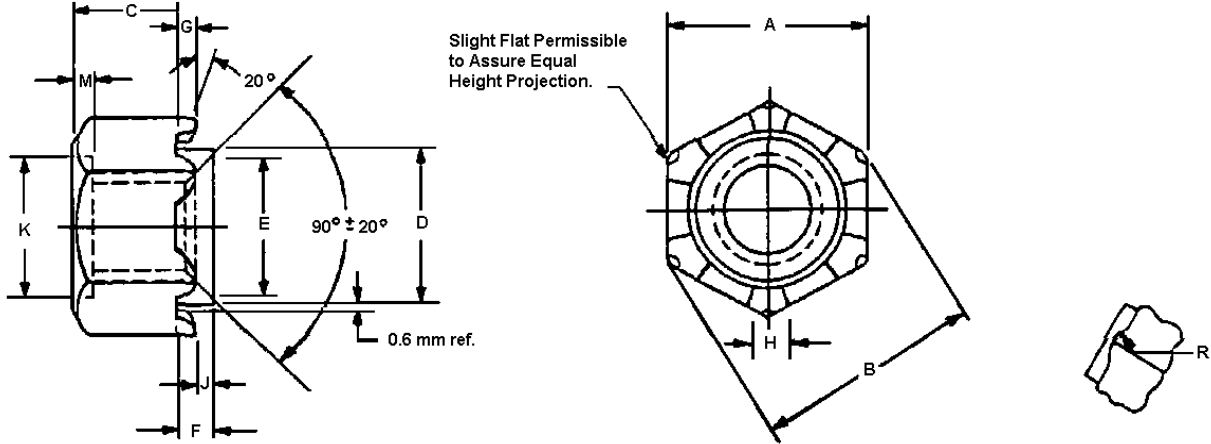

### 6 PROJECTIONS HEAVY SERIES - LONG PILOT

Dimensions in millimetres

Nominal Size		M6*	M8*	M10	M12	M14*	M16
Pitch, Nominal		1	1.25	1.5	1.75	2	2
A	Width Across Flats	max. 13 min. 12.73	max. 15 min. 14.7	max. 18 min. 17.7	max. 21 min. 20.6	max. 24 min. 23.6	max. 26 min. 24.9
B	Width Across Corners	min. 14.38	min. 16.6	min. 20.0	min. 23.3	min. 26.7	min. 29.1
C	Nut Thickness	max. 8 min. 7.5	max. 9.3 min. 8.8	max. 12.2 min. 11.7	max. 14.3 min. 13.8	max. 16.5 min. 15.9	max. 19 min. 18.4
D	Pilot Diameter	max. 9.00 min. 8.70	max. 11.1 min. 10.8	max. 13.4 min. 13.1	max. 16.1 min. 15.8	max. 19 min. 18.7	max. 20.5 min. 20.2
E	Chamfer Diameter	min. 6.6	min. 8.6	min. 10.7	min. 12.8	min. 15	min. 17
F	Pilot Height	max. 1.93 min. 1.67	max. 1.93 min. 1.67	max. 1.93 min. 1.67	max. 1.93 min. 1.67	max. 1.93 min. 1.67	max. 1.93 min. 1.67
G	Projection Height	max. 1.08 min. .92	max. 1.08 min. .92	max. 1.08 min. .92	max. 1.08 min. .92	max. 1.08 min. .92	max. 1.08 min. .92
H	Projection Width	min. 3.17	min. 3.69	min. 4.49	min. 5.29	min. 6.09	min. 6.61
J	Projection Locating Height	ref. 0.8	ref. 0.8	ref. 0.8	ref. 0.8	ref. 0.8	ref. 0.8
K	Counterbore Diameter	max. 8.40 min. 8.15	max. 10.5 min. 10.2	max. 12.8 min. 12.5	max. 15.3 min. 15	max. 18.3 min. 18	max. 19.5 min. 19.2
M	Counterbore Depth	max. 1.5 min. 1.25	max. 1.5 min. 1.25	max. 1.5 min. 1.25	max. 1.5 min. 1.25	max. 1.5 min. 1.25	max. 1.5 min. 1.25
R	Projection Radius	nom. 1.96	nom. 2.44	nom. 3.31	nom. 4.34	nom. 5.53	nom. 6.38
	Plate Thickness	max. 6.5 min. 1.8	max. 6.5 min. 1.8	max. 6.5 min. 1.8	max. 6.5 min. 1.8	max. 6.5 min. 1.8	max. 6.5 min. 1.8
	Hole Size in Plate	max. 9.4 min. 9.1	max. 11.5 min. 11.2	max. 13.8 min. 13.5	max. 16.5 min. 16.2	max. 19.5 min. 19.2	max. 21 min. 20.7
	Current Case Part No.	830-62006	830-62008	830-62010	830-62012	830-62014	830-62016
	Replaced IH Part No.	--	30696R1	30704R1	30705R1	30706R1	30707R1
	New Holland Part No.		87026741		87017612		87020955

\*Non-Preferred

\*\* For General Specifications See Page 1 \*\*

Supersedes Issue:	Dated:	Page:
EM-070	JUL 02	4 of 6

ELECTRONIC DOCUMENT IN THE VIEWER IS CONTROLLED. PRINTED COPY IS AN UNCONTROLLED DOCUMENT.

## HEX PILOTED PROJECTION WELD NUTS

Preferred Parts for European Design

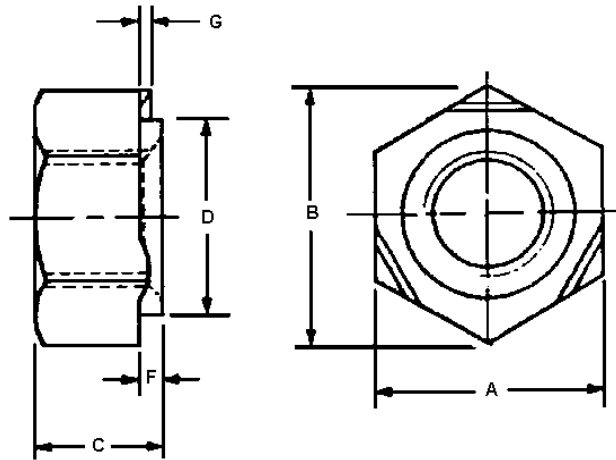

### 3-PROJECTIONS

Dimensions in millimetres

Dimensions are for reference only, nuts are to conform to DIN 929.

Nominal Size		M4	M5	M6	M8	
Pitch, Nominal		0.7	0.8	1	1.25	
A	Width Across Flats max.	9	10	11	14	
B	Width Across Corners min.	9.83	10.95	12.02	15.38	
C	Nut Thickness max.	3.5	4	5	6.5	
D	Pilot Diameter	max.	5.97	6.96	7.96	10.45
		min.	5.895	6.87	7.87	10.34
F	Pilot Height	max.	0.65	0.7	0.75	0.9
		min.	0.55	0.6	0.60	0.75
G	Projection Height	max.	0.35	0.4	0.4	0.5
		min.	0.25	0.3	0.3	0.35
Plate Thickness	max.	3	3.5	4	4.5	
	min.	0.75	0.88	0.88	1	
Hole Size in Plate	max.	6.3	7.3	8.3	10.8	
	min.	6	7	8	10.5	
Current Case Part No.		830-33004	830-33005	830-33006	830-33008	
Replaced IH Part No.		905714R1	3234542R1	934779R1	934761R1	
Replaced Vibromax Part No.		--	2125/20050	2125/20060	2125/20080	
Replaced Poclairn Part No.		--	P1334504X	P134555F	P134588R	
New Holland Part No.		86639953	86639233	86639234	86625084	

\*\* For General Specifications See Page 1 \*\*

Supersedes Issue:	Dated:	Page:
EM-070	JUL 02	5 of 6

ELECTRONIC DOCUMENT IN THE VIEWER IS CONTROLLED. PRINTED COPY IS AN UNCONTROLLED DOCUMENT.

### HEX PILOTED PROJECTION WELD NUTS

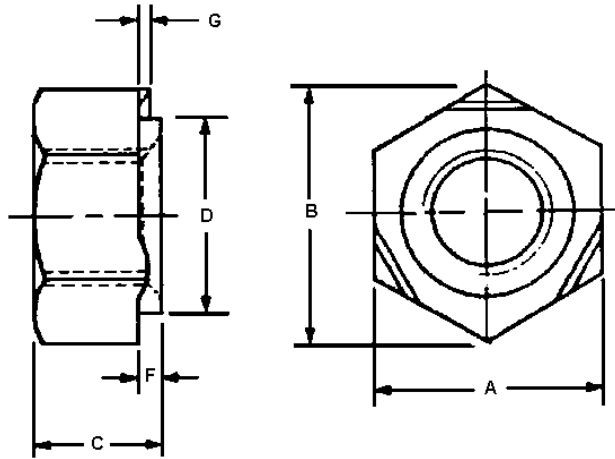

3-PROJECTIONS

Dimensions in millimetres

Dimensions are for reference only, nuts are to conform to DIN 929.

Nominal Size			M10	M12	M14*	M16
Pitch, Nominal			1.5	1.75	2	2
A	Width Across Flats	max.	17	19	22	24
B	Width Across Corners	min.	18.74	20.91	24.27	26.51
C	Nut Thickness	max.	8	10	11	13
D	Pilot Diameter	max.	12.45	14.75	16.75	18.735
		min.	12.34	14.64	16.64	18.605
F	Pilot Height	max.	1.15	1.4	1.8	1.8
		min.	0.95	1.2	1.6	1.6
G	Projection Height	max.	0.65	0.8	1	1
		min.	0.5	0.6	0.8	0.8
	Plate Thickness	max.	5	5	6	6
		min.	1.25	1.5	2	2
	Hole Size in Plate	max.	12.8	15.1	17.1	19.1
		min.	12.5	14.8	16.8	18.8
Current Case Part No.			830-33010	830-33012	830-33014	830-33016
Replaced IH Part No.			905354R1	934762R1	934051R1	905687R1
Replaced Vibromax Part No.			2125/20100	2125/20120	--	2125/20160
Replaced Poclairn Part No.			P134580H	P834501R	P1334505Z	P834502S
New Holland Part No.			86013959	86619782	--	86619383

\* Size to be avoided where possible.

\*\* For General Specifications See Page 1 \*\*

Supersedes Issue:	Dated:	Page:
EM-070	JUL 02	6 of 6