



ATLAS METAL

1135 N.W. 159th DRIVE, MIAMI, FLORIDA 33169

TEL 305.625.2451

TOLL FREE 800.762.7565

FAX 305.623.0475

WWW.ATLASFOODSERV.COM

SALES@ATLASFOODSERV.COM

Project: _____

Item No.: _____

Quantity: _____

DROP-IN SERVING EQUIPMENT



WH-3

HOT PAN

Electrically Heated Single Control

- WH-2
- WH-3
- WH-4
- WH-5
- WH-6

SPECIFICATIONS

TOP: Constructed of 18 gauge, type 304 stainless steel, die stamped flange with a raised perimeter bead. There shall be a solid vinyl gasket under the beaded edge to form a seal to the counter top, thus preventing seepage or marring of the counter top. Embossed mounting lugs are provided along the inner surface of the top to hold the removable separator channels in place.

LINER: The inner liner shall be 18 gauge, type 304 stainless steel, one piece construction, all welded ground and polished to a uniform finish. All corners are covered with a minimum 1/4" radius. A 3/4" dia. drain, with strainer, brass nipple, and valve is provided.

INSULATION: The pan is fully insulated with high density fiberglass insulation, 1" thick on all sides, 2" thick on the bottom and enclosed by a 22 gauge galvanized steel outer case.

ELECTRICAL: The unit is provided with individual 850 watt heating elements, pre-wired to a single thermostat control with a pilot light. A 6' long, 3-wire cord and plug is provided, extending from the control box located under the unit, on operator's left. Bottom of outer case can be removed for access to electrical components. Available for single phase power only.

Specifications subject to change without notice.

STANDARD FEATURES

- Fully insulated to retain heat - protects fixtures and saves energy
- Open Bain Marie construction
- Thermostatically controlled
- Factory applied gasket - makes installation a snap and seals units to the counter top, thus eliminating seepage
- Accommodates standard 12" X 20" pans with the use of separator channel(s), or fractional size pans with the use of optional adapter bars
- Wet or Dry Operation
- 1-Year Parts & Labor Warranty
- UL Listed, ETL Listed

ACCESSORIES

- Stainless steel adapter bars (pgs. DI-51-52)
- Stainless steel adapter plates (pgs. DI-51-52)
- CP - Cover Plate with handles, S/S
- RDVE - Rear Drain Valve Extension (1) required
- RT-1 - Remote Thermostat for counter installation, 36" long
- RTL-1 - Remote Thermostat for counter installation, 72" long
- MS - Master on/off switch
- AF - Automatic water fill

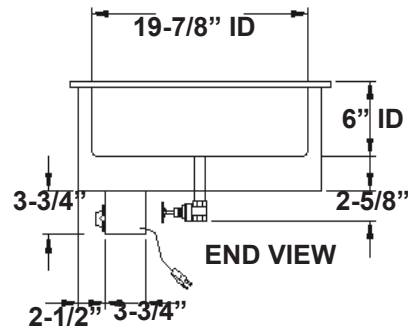
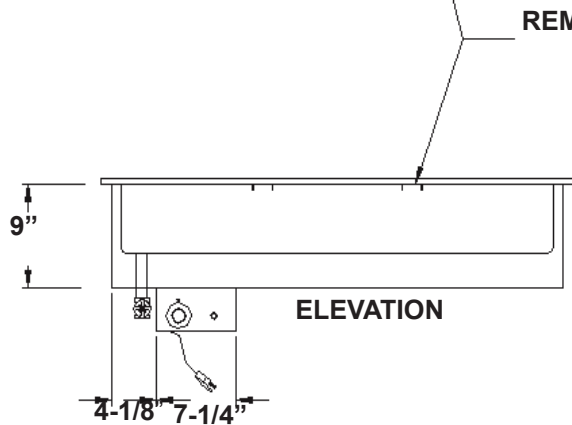
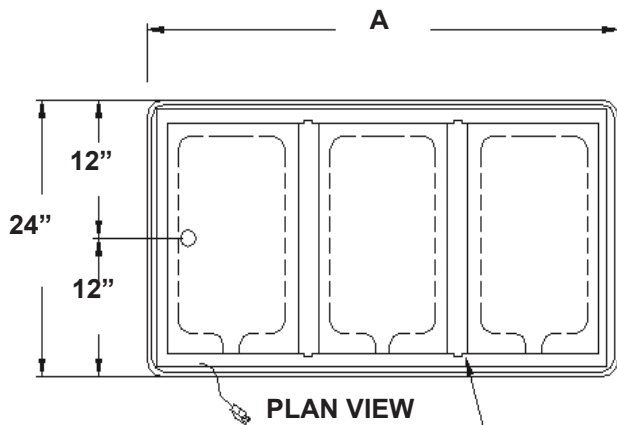

Electrical Characteristics

MODEL	WATTAGE	VOLTAGE/KW/AMPS	NEMA # PLUG
WH-2	850WATT	120V - 1.7KW - 14.2	5-20P
		208V - 1.7KW - 8.2	6-15P
		240V - 1.7KW - 7.1	6-15P
	1000WATT	120V - 2.0KW - 16.7	5-30P
		208V - 2.0KW - 9.6	6-15P
		240V - 2.0KW - 8.3	6-15P
WH-3	850WATT	120V - 2.55KW - 21.3	5-30P
		208V - 2.55KW - 12.3	L6-20P
		240V - 2.55KW - 10.6	6-15P
	1000WATT	120V - 3.0KW - 25.0	5-50P
		208V - 3.0KW - 14.4	L6-20P
		240V - 3.0KW - 12.5	L6-20P
WH-4	850WATT	208V - 3.4KW - 16.4	L6-30P
		240V - 3.4KW - 14.2	L6-20P
	1000WATT	208V - 4.0KW - 19.2	L6-30P
		240V - 4.0KW - 16.7	L6-30P
WH-5	850WATT	208V - 4.25KW - 20.4	L6-30P
		240V - 4.25KW - 17.7	L6-30P
	1000WATT	208V - 5.0KW - 24.0	L6-30P
		240V - 5.0KW - 20.8	L6-30P
WH-6	850WATT	208V - 5.1KW - 24.5	6-50P
		240V - 5.1KW - 21.3	L6-30P
	1000WATT	208V - 6.0KW - 28.8	6-50P
		240V - 6.0KW - 25.0	6-50P

MODEL	"A"	PAN SIZE	COUNTER CUT-OUT (REQUIRED) W X L	SHIP WT. (LBS.)
WH-2	29-3/4" (75.5cm)	19-7/8" X 25-1/2" X 6" (50.4 X 64.7 X 15.2cm)	22-1/4" X 28" (56.5 X 71.1cm)	116 (52.6kg)
WH-3	43-1/2" (110.4cm)	19-7/8" X 39-1/4" X 6" (50.4 X 99.6 X 15.2cm)	22-1/4" X 41-3/4" (56.5 X 106cm)	148 (67.1kg)
WH-4	57-1/4" (145.4cm)	19-7/8" X 53" X 6" (50.4 X 134.6 X 15.2cm)	22-1/4" X 55-1/2" (56.5 X 140cm)	174 (78.9kg)
WH-5	71" (180.3cm)	19-7/8" X 66-3/4" X 6" (50.4 X 169.5 X 15.2cm)	22-1/4" X 69-1/4" (56.5 X 175.8cm)	210 (95.3kg)
WH-6	84-3/4" (215.2cm)	19-7/8" X 80-1/2" X 6" (50.4 X 204.4 X 15.2cm)	22-1/4" X 83" (56.5 X 210.8cm)	227 (102.9kg)

Note: Numeral following the model letters denotes the 12X20 pan capacity