

PRODUCT SPECIFICATION

# FSE Gas Fryers

## features

Model: CULGF90NG



JNG

This gas fryer from FSE is a must have for any foodservice commercial kitchen. Frying is a popular cooking technique used in most kitchens, because who can resist a gooey mozzarella stick, or the satisfying crunch of a juicy, fried chicken breast. And, of course, let's not forget the classic French fry! Durable 16-gauge, stainless steel construction makes this fryer corrosion-resistant and easy-to-clean. ETL Listed and ETL Sanitation, this unit is backed with a 1-year parts and labor, and a limited 5-year tank warranty.

### FRYER SYSTEM

- Thermostat maintains temperature range between 200°F and 400°F.
- Temperature limit automatically shuts off all gas flow if the fryer temperature exceeds 450°F.
- Integrated gas control valve will prevent gas flow to the main burner until pilot is established. If flame goes out, gas flow shuts off automatically.
- Front 1-1/4" drain for quick draining.
- One drain valve extension.

### CONSTRUCTION

- Welded 16-gauge stainless steel tank with super smooth machine finish for easy cleaning.

### FOOD SERVICE ESSENTIALS

For Food Service Professionals

#### STANDARD FEATURES

- Heavy-duty, 16-gauge stainless steel fry tank
- Cabinet is constructed with stainless steel front and sides, and galvanized sides and back
- Thermostat range of 200°F to 400°F
- Long-lasting baffles mounted in heat exchange tubes for maximum heating and combustion efficiency
- Standing pilot light design provides a ready flame when heat is required
- Automatic shut-off when fryer exceeds 450°F
- Front 1-1/4" drain for quick removal of oil
- Comes with two nickel-plated, oblong wire mesh fry baskets
- 6" adjustable legs

- Heavy-duty, stainless steel ledge, front, sides, with galvanized sides and back.
- One nickel-plated tube rack.
- Built-in heat deflector.
- 6" adjustable legs.

### FRYER FEATURES

- Available in 90,000 BTU w/ 40-lb. oil capacity
- Natural gas
- Comes with two nickel-plated, oblong wire mesh fry baskets.
- Includes Robert Shaw components that are made in the USA.
- 1/2" NPT rear gas connection and pressure regulator.

### FRYER ACCESSORIES (optional)

- Stainless steel cover
- Casters
- Joiner Strips
- Splash Guard
- Fryer baskets available in a variety of sizes

*RESIDENTIAL: FSE assumes no liability for parts or labor coverage for component failure, factory defect or any other damages for units installed in non-commercial foodservice or residential applications.*



**Attention CA Residents**  
**PROP 65 WARNING**

This product can expose you to chemicals, including lead, which are known to the State of California to cause cancer, birth defects, or other reproductive harm.

For more information, go to [www.P65warnings.ca.gov](http://www.P65warnings.ca.gov)

MADE IN CHINA



PRODUCT SPECIFICATION

# FSE Gas Fryers

## features

Model: CULGF90NG

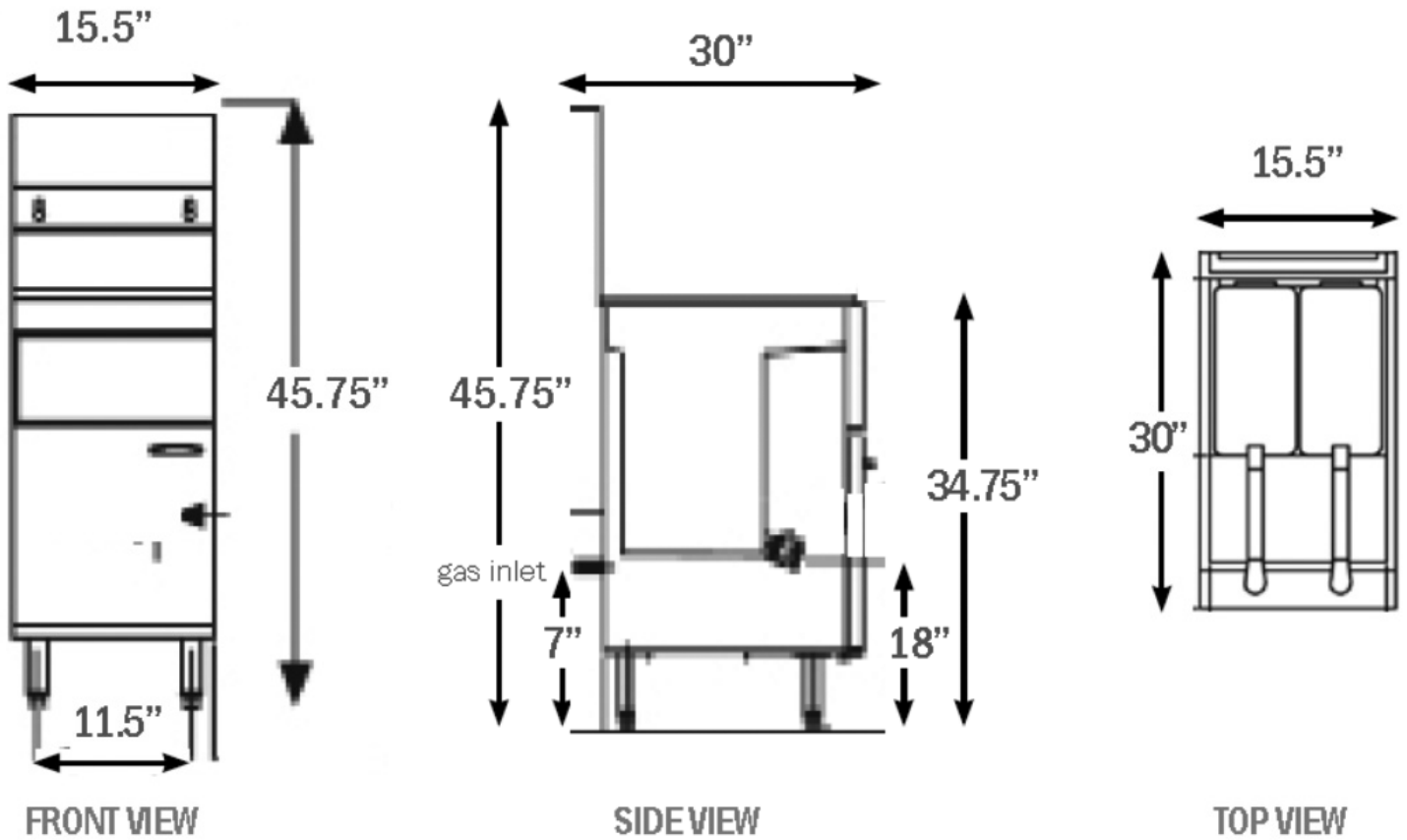

## PRODUCT DETAILS

### GRIDDLES

Model Number	CULGF90NG
Total BTU	90,000
Overall Dimensions (in)	45-3/4"H x 15-1/2"W x 30"D
Oil Capacity (lbs)	35-40
Number of Frypots	1
Number of Fry Baskets	2
Net Weight (lbs)	152
Gross Weight (lbs)	169
Shipping Dimensions (in)	53-1/2"H x 15-1/2"W x 30-1/4"D

