

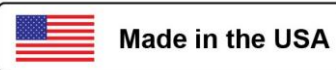

JOB:
ITEM:
QTY:



BUN PAN DOLLIES

APPLICATION:

These dollies provide transportation and storage of 13"x18" and 18"x26" pans.

MATERIAL:

Framework is constructed of 2"x2"x.125" wall angle. Models #1193 and #1194 handles and sides are constructed of 1"x1"x.070" wall tubing.

CASTERS:

These dollies come equipped with four 5" platform type swivel casters.

GUARANTEE:

These dollies carry a **Lifetime Guarantee** against rust and corrosion and also carry a **Five-Year Guarantee** against workmanship and material defects.



Model #1193



Phone: 800-255-0104
Fax: 877-877-7687
www.newageindustrial.com
sales@newageindustrial.com

New Age Industrial reserves the right to modify or make changes at any time without notice to materials and specifications.

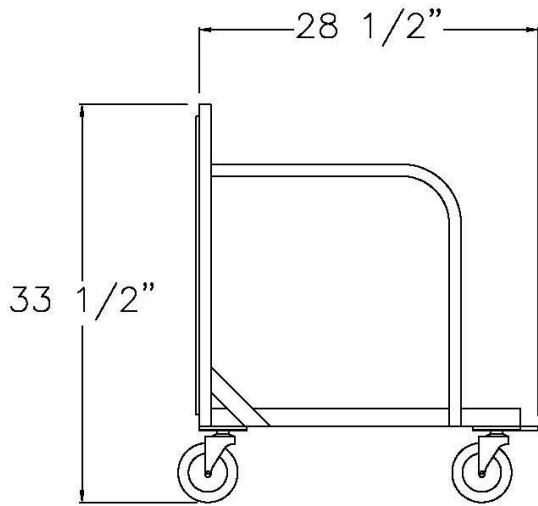

Model #1193

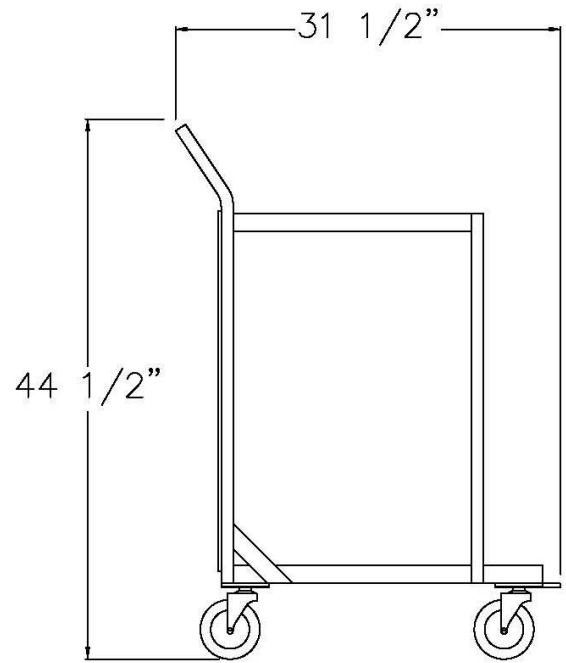

Model #1194

Model No.	Size-W	Size-H	Size-D	Wt. Cap.
Angle Dolly Without Sides or Handle				
1192	18 7/8"	7"	27"	800#
Angle Dolly With Sides & Handle				
1193	21"	33 1/2"	27"	1000#
Two Tier Angle Dolly With Sides & Handle				
1194	21"	44 1/2"	30"	1200#
Aluminum Drag Hook				
1199			34 1/2" Long	



Phone: 800-255-0104
 Fax: 877-877-7687
www.newageindustrial.com
sales@newageindustrial.com

New Age Industrial reserves the right to modify or make changes at any time without notice to materials and specifications.