

PESO NETTO	Kg	71
NET WEIGHT	pounds	156.2

POWER SUPPLY	INSTALLED POWER	LINE POWER	SUPPLY CABLE SECTION
208 - 240 V 60 Hz	3.0 – 3.8 kW	18 A	3x1,5 mm ²

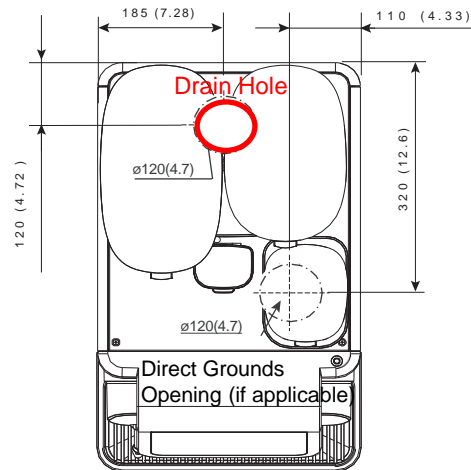

- SWITCH** - Omnipolar, 3mm opening contact distance
- GROUNDING** - Protection from leakage current with a value equal to 30mA
- Required
- HYDRAULIC CONNECTION** - ø 3/8 gas
- HYDRAULIC FEEDING PRESSURE** - 0 ÷ 6 bar (0.6 MPa)
- WATER DISCHARGE** - ø min. 50mm



208-240V single phase electrical supply to espresso machine (L6-30 Plug) – Outlet ready for installers.



3/8" cold water supply with shut off valve (site must have ready) – refer to local codes for placement and needs of external vacuum breaker

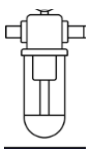

water filter required (not provided)



3/8" BSPB cold water supply line braided hose - **supplied with machine**

3/8" **BLUE** milk drain terminating within 4ft- **supplied with machine**



3/4" Flex main drain terminating within 4ft - **supplied with machine**



3" Diameter hole in counter – Drilled & ready for installers.