



ALWAYS HOT

Installation Guide

Conversion Kits: CK-31, CK-32, CK-33,
CK-34, CK-42, CK-43, CK-44, CK-45



WARNING

This conversion kit shall be installed by a qualified service agency in accordance with the manufacturer's instructions and all applicable codes and requirements of the authority having jurisdiction. The information in these instructions must be followed to minimize the risk of fire or explosion or to prevent property damage, personal injury or death. The qualified service agency is responsible for the proper installation of this kit. The installation is not proper and complete until the operation of the converted appliance is checked as specified in the manufacturer's instructions supplied with the kit.



WARNING

Cette trousse de conversion ne doit être installée que par le représentant d'un organisme qualifié et conformément aux instructions du fabricant et à tous les codes et exigences pertinents de l'autorité compétente. Les instructions de cette notice doivent être suivies afin de réduire au minimum le risque d'incendie ou d'explosion, de dommage matériel, de blessure ou de mort. L'organisme qualifié est responsable de l'installation adéquate de cette trousse. L'installation n'est pas adéquate ni complète tant que le bon fonctionnement de l'appareil converti n'a pas été vérifié selon les instructions du fabricant fournies avec la trousse.

In Canada:

The conversion shall be carried out in accordance with the requirements of the provincial authorities having jurisdiction and in accordance with the requirements of the CAN-B149.1 and CAN1-B149.2 Installation Code.

LA CONVERSION DOIT ÊTRE EFFECTUÉE CONFORMÉMENT AUX EXIGENCES DE L'AUTORITÉ PROVINCIALE AYANT JURIDICTION ET AUX, CSA-B149.1, ET CAN-B149.2.

*A qualified service agency is any individual, firm, corporation or company which either in person or through a representative is engaged in and is responsible for the connection, utilization, repair or servicing of gas utilization equipment or accessories; who is experienced in such work, familiar with all precautions required, and has complied with all of the requirements of the authority having jurisdiction.

*Conversion acceptable for install locations 0-2,000 feet. See heater installation manual for procedures to adjust above 2,000 feet.

NORITZ America Corporation
11160 Grace Avenue
Fountain Valley, CA 92708
866-766-7489
www.noritz.com

CK-IM-6
Rev. 04/16



1. Before Conversion

Before attempting to convert a unit, verify that the proper kit has been purchased for the model type*:

Conversion Kit	Model	Conversion Type
CK-31	NRC98-DV	Propane to Natural Gas
CK-32	GQ-C2857WS-FF US	Natural Gas to Propane
CK-33	NRC98-OD	Propane to Natural Gas
CK-34	GQ-C2857WS US	Natural Gas to Propane
CK-42	NRC83-DV	Propane to Natural Gas
CK-43		Natural Gas to Propane
CK-44	NRC83-OD	Propane to Natural Gas
CK-45		Natural Gas to Propane

*The model type can be verified from the rating plate located on the front cover of the water heater.







Tools Required:

- Noritz Remote Controller (RC-7651M)
- Manometer (Capable of displaying digits in tenths (i.e. 2.4) and up to 20" W.C.)
- Philips screwdriver (#2 Recommended)
- Pliers
- Gas leakage device detector

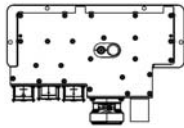
NOTE: Do not attempt to perform a conversion without access to a manometer and a Noritz remote controller. A digital manometer is recommended.

2. Included Parts

The following parts are supplied in the conversion kit. Check for any missing items before starting the conversion.

Parts	Shape	Quantity
Manifold Plate		1
O-Ring		2
Main Damper		1
New Inlet and Manifold Pressure Rating Sticker (English)		1
New Inlet and Manifold Pressure Rating Sticker (French) -DV only		1
Date, Gas Type, Kit Number, Name of Company Sticker (English)		1
Date, Gas Type, Kit Number, Name of Company Sticker (French) -DV only		1

3. Conversion Procedure

Parts Replacement:

- 1) If the display on the remote controller is on, turn off the unit by pressing the “ON/OFF” button on the remote controller. There should be no display on the remote controller.
- 2) Turn off electrical power to heater by disconnecting the electrical plug from the outlet or shut off the breaker providing power to water heater.
- 3) Turn off the gas supply to the water heater by closing the gas shut-off valve.
- 4) Remove the front cover of the unit by removing the 4 screws holding it to the case.

- 5) Locate the colored wire connectors from the electrical solenoids on the manifold from the locations indicated in Figure 1 on the following page. Follow the wires to a white clip and disconnect it. Disconnect the gas pipe from the gas supply inlet by removing the C-Clamp at the bottom of the gas pipe (Figure 2). For easier access remove the mounting plate with the current leakage safety device in front of the gas pipe.

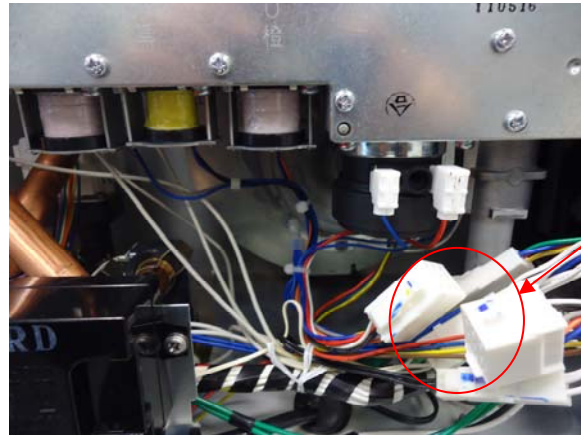

Disconnect White Clip

- 6) Then locate and remove the 4 screws with a Philips screwdriver (Figure 1). Do NOT use a power drill. Once screws are removed, pull the gas pipe from the gas fitting. When the pipe and manifold have been detached, remove the gas pipe from the manifold inlet. **Remember to remove the manifold screw. This will be used on the new manifold plate.** Discard the original manifold plate.

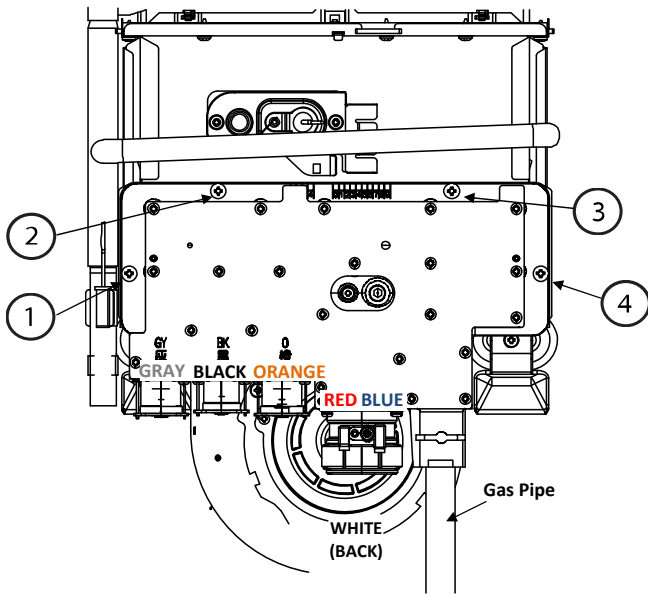

FIGURE 1

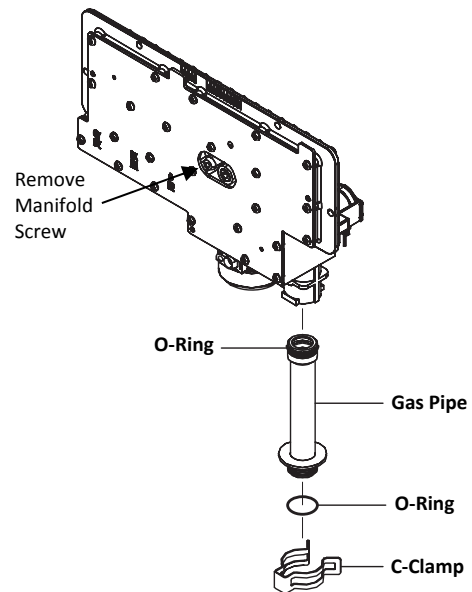

FIGURE 2

- 7) After manifold plate is removed, the existing damper will be exposed as indicated in Figure 3 below. Remove screws (1), (2), (3), and then pull the damper off the burner assembly. Check for proper size of damper with the chart below and replace with new damper that was included with your gas conversion kit.

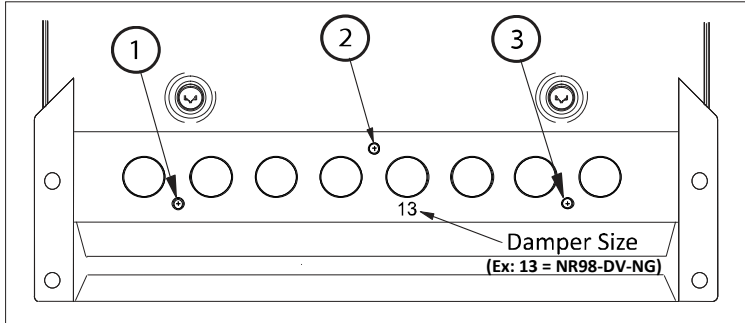

FIGURE 3

Model Name	Gas Conversion	Damper Size
NRC98-DV	NG to LP	17-16
GQ-C2857WS-FF US	LP to NG	17-12
NRC98-OD	NG to LP	17-15
GQ-C2857WS US	LP to NG	17-12
NRC83-DV	NG to LP	17-16
	LP to NG	17-12
NRC83-OD	NG to LP	17-15
	LP to NG	17-12

- 8) Locate the black O-rings on the gas pipe as indicated in Figure 2 & 4. If torn or damaged, remove and replace O-rings with the new O-rings supplied in the conversion kit. Discard the old O-rings.
- 9) Insert the new manifold plate supplied with the conversion kit. The orifice size of the gas manifold plate should be marked as follows (check Figure 5):

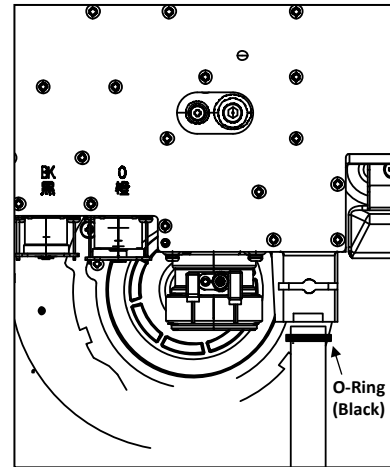

FIGURE 4

Identifying the Proper Manifold Plate per Gas Type:

For **NRC98-DV, GQ-C2857WS-FF US** and **NRC83-DV** models:

- To fire Natural Gas (NG) – 2.6
- To fire Propane Gas (LP) – 1.6

For **NRC98-OD, GQ-C2857WS US** and **NRC83-OD** models:

- To fire Natural Gas (NG) – 2.5
- To fire Propane Gas (LP) – 1.5

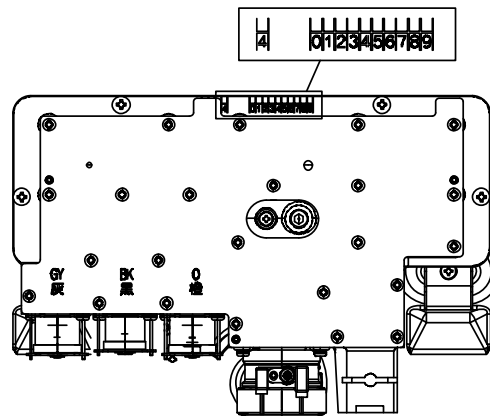

FIGURE 5

DO NOT continue with conversion if manifold plate is incorrect.

- 10) Make sure that the O-Ring is secured properly in place. **Failure to do so will cause gas leaks, possibly resulting in severe personal injury or death.**
- 11) Once O-ring is in place, slide the gas pipe into the manifold inlet. Make sure that the gas pipe is completely inserted into the manifold inlet in order to prevent any gas from leaking.
- 12) Insert gas pipe into the gas supply inlet and hold the manifold plate in place.
- 13) Secure the new manifold plate to the unit using the screws removed in Step 7. The screws need only to be hand tightened and should not be tightened using a drill. First, insert screws 1-4 from Figure 1, but do not fully tighten these screws. Once all screws are inserted, proceed to completely tighten screws 1-4.

NOTE: When tightening the screws, be certain to not apply excess force as the screws should turn easily. If extra force is required, stop, remove the screw and tighten by hand first. Excess force can strip out the original holes.

- 14) Attach C-Clamp at the bottom of the gas pipe (Figure 2). **Failure to do so will cause gas leaks, possibly resulting in severe personal injury or death.**
- 15) Reconnect the white clip that contains the wires to the electrical solenoids on the manifold from the locations indicated in Figure 1.
- 16) Before replacing the front cover, the unit must be adjusted and tested as described in the next section.

Adjustments:

- 1) Before electrical power is applied to the unit, install a remote controller to the unit if it is not already installed.
- 2) Reconnect the electrical power to the unit.
- 3) Within the first ten minutes of connecting electrical power to the unit, but before pressing the Power ON/OFF button (display should be blank), hold the up button on the remote controller until the display blinks "99". This will put the unit into Maintenance Writer mode. If pressing the up button does not put the unit into Maintenance Writer mode, make sure the remote display is blank, unplug the unit for sixty seconds, and try again.
- 4) After accessing the Maintenance Writer mode, use the "up" and "down" buttons to change the Maintenance Writer item number display. Pressing the "FLOW METER ALARM SET" button for 0.5 seconds will change the item number setting from "ON" to "OFF". If the Priority lamp is flashing when an item number is displayed, this indicates an "ON" setting for that item number, and if the Priority lamp is off, the item number is "OFF".

- 5) Change “FC” and “FE” from OFF to ON. The priority light should be flashing on both item numbers after pressing the “FLOW METER ALARM SET”.
- 6) Choose the proper conversion setting from the chart below and set the “A1” Maintenance Writer item number according to the chart below.

NOTE: DO NOT change the other item numbers. This will cause a fault in the water heater.

Models	Desired Gas Type	A1
NRC98-DV, NRC98-OD, GQ-C2857WS-FF US, GQ-C2857WS US, NRC83-DV, NRC83-OD	Natural Gas	ON
	Propane	OFF

ON: “Priority” light is flashing.
OFF: “Priority” light is off.

- 7) After setting the “A1” item number for the desired gas type, press and hold the “up” and “down” buttons together for five seconds to confirm the new settings. The remote controller will emit a tone and the display will go blank when the settings are confirmed. If this is not done, the unit will not put the setting changes into effect.

NOTE: The setting changes can be cancelled by pressing the Power ON/OFF button before confirming the settings, or if the unit is left alone for ten minutes without confirming the settings. If the default setting needs to be changed again, disconnect the electrical power to the unit, reconnect it and repeat this procedure.

Testing:

- 1) Before turning on the gas supply to the unit, verify that the inlet gas supply pressure is within the following operating ranges:
 - a. Natural Gas Supply: Min. 4 – Max. 10.5 inches
 - b. Propane Supply: Min. 8 – Max. 14 inches

NOTE: If the supply pressure is higher than the maximum allowable pressure, adjust the pressure at the regulator or install a secondary regulator on the supply line connected to the water heater. **DO NOT attempt to operate heater if gas supply pressure is not within ranges specified above. High supply pressure can damage the unit and possibly cause a gas leak.**

Next, verify the supply pressure at the unit. To check the gas supply pressure to the unit, a tap is provided on the gas inlet (Figure 6 below).

Make sure gas supply is turned off to the unit. Remove the hex head Philips screw from the tap. A 9/32” nut driver is recommended for the removal of this screw. If a nut driver is not available, a Philips screwdriver can be used. Gently remove the screw, so as not to strip out the screw.

- 2) Connect a manometer to the tap by using a silicone tube. Turn on gas supply to unit and confirm the supply pressure.
- 3) After supply pressure to heater has been confirmed, turn off the gas supply, remove the manometer tube and replace the hex head screw.
- 4) The manifold pressure will also have to be checked using a manometer (digital manometer is suggested). In order to check the gas manifold pressure, a tap is provided on the manifold plate inside the unit (Figure 7). The pressure can be checked either by removing the Philips head screw (1) and connecting a manometer with a silicon tube, or by removing the 1/8" NPT screw (2) with an Allen wrench and connecting the appropriate pressure gauge. Be sure to zero out the manometer before attaching it to the tap.

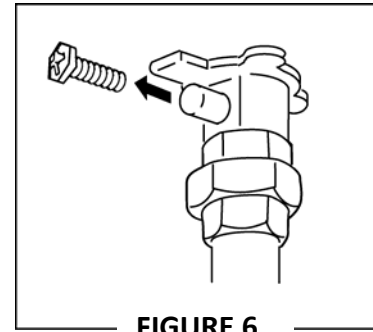

FIGURE 6

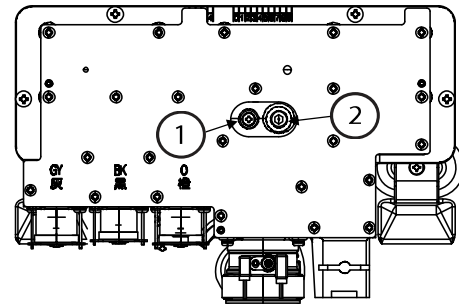

FIGURE 7

- 5) Turn on the gas supply to the unit.
- 6) Before firing the unit, check for gas leaks at the gas inlet fitting and around the manifold plate using a gas leak detection device.
- 7) If not already on, press the Power "ON/OFF" button so that the unit is in standby mode. The priority light should be on.
- 8) Open up several hot water fixtures (high flow rate is required through the unit) and allow the unit to go through its startup sequence. It may take several ignition attempts in order to purge air from the gas chambers. If an "11" code appears on the remote controller, reset the unit by pressing the Power button on the remote controller off and then on again.

- 9) Once the heater has ignited and has begun to run continuously, locate the manifold adjustment buttons on the right side of the circuit board (Figure 8).
- 10) Press and hold the maximum pressure set button. Verify from the tables below that the appropriate pressure is read from the manometer. If the pressure needs adjustment, use the manifold pressure increase and decrease buttons to adjust to the correct pressure, while continuing to hold down the maximum pressure set button.
- 11) Press and hold the minimum pressure set button. Verify from the tables on the following page that the appropriate pressure is read from the manometer. If the pressure needs adjustment, use the manifold pressure increase and decrease buttons to adjust to the correct pressure, while continuing to hold down the minimum pressure set button.

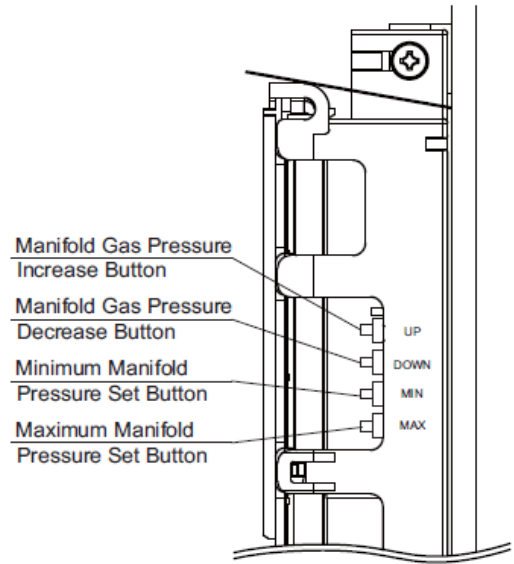

FIGURE 8

Model Name	Gas Type	Supply Pressure (inch H ₂ O)	Manifold Pressure (inch H ₂ O) Cover Off	
			Max Value	Min Value
NRC98-DV	NG	7.9	3.01	1.12
	LP	11.0	3.85	1.50
NRC98-OD	NG	7.9	2.60	0.95
	LP	11.0	3.65	1.25
GQ-C2857WS-FF US	NG	7.9	3.05	0.90
	LP	11.0	3.85	1.00
GQ-C2857WS US	NG	7.9	2.65	0.80
	LP	11.0	3.70	1.00
NRC83-DV	NG	7.9	2.95	1.10
	LP	11.0	3.60	1.35
NRC83-OD	NG	7.9	2.60	0.95
	LP	11.0	3.65	1.25

Manifold Gas Pressure Maximum and Minimum Values

After the manifold pressures have been confirmed, verify that the flame is a steady blue color using the inspection window (Figure 9).

- 12) Turn off water and gas to unit. Replace screw from manifold tap and turn gas back on to unit.
- 13) Perform a final gas leak check around the entire manifold plate, especially near the gas pipe and manifold inlet, using a gas leak detection device.

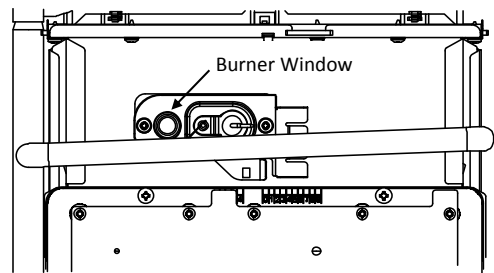
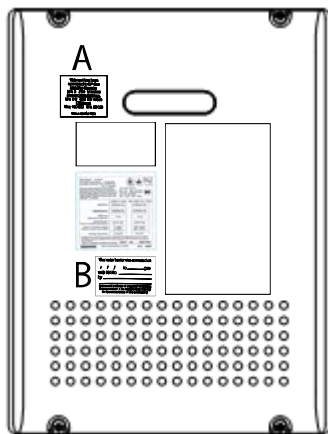

FIGURE 9

- 14) If the remote controller needs to be removed, disconnect electrical power to heater and proceed to remove controller connections.

Apply conversion labels:

- 1) Replace the front cover of the unit using the 4 screws previously removed.
- 2) Locate the 2 conversion stickers in English supplied in the conversion kit. ***For water heaters certified for use in Canada locate the 2 conversion stickers in French.**
- 3) Place the sticker indicating the new inlet and manifold pressures directly above the rating sticker so as not to cover any existing markings as indicated by "A" in Figure 10. ***For water heaters certified for use in Canada place French sticker with new pressures next to English sticker.**
- 4) Fill out the required information on the remaining sticker indicating the date, gas type, kit number, and name of the company performing the conversion. Place this sticker on the front cover as indicated by "B" in Figure 10. Do not to cover any existing markings. ***For water heaters certified for use in Canada place French sticker with agency information next to English sticker.**



NRC83-DV, NRC98-DV
& GQ-C2857WS-FF US

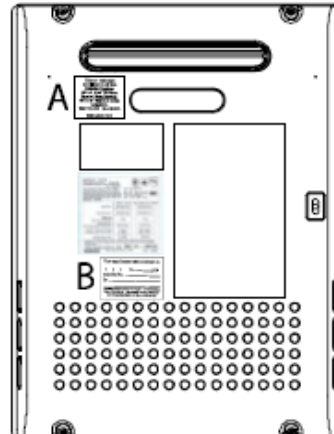

NRC83-OD, NRC98-OD
& GQ-C2857WS US

FIGURE 10

Installation Checklist:

Parts Replacement:

- Remove existing manifold plate, main damper, and O-ring. Discard these parts.
- Replace with new manifold plate, main damper, and O-ring.
- Make sure that manifold plate, main damper, and O-ring are securely in place.

Adjustments:

- Access Maintenance Writer mode and set the A1 item number to desired gas type.
- Confirm gas type settings.

Testing:

- Before opening gas valve to heater, verify that gas supply pressure is within operating range of heater.
- If gas supply pressure is not within specification, adjust the pressure at the regulator or install a secondary regulator on the supply line connected to the water heater.
- Remove hex Philips screw from inlet of Noritz heater and confirm gas supply pressure at unit with manometer. Replace screw after confirmation of gas supply pressure.
- Remove hex Philips screw or 1/8" NPT screw from gas valve and connect manometer to gas valve.
- Check for gas leaks around gas inlet fitting and manifold plate using a gas leak detection device.
- Check and confirm correct manifold pressures. Make adjustments if necessary. Replace screw after manifold pressures have been confirmed.
- Perform final gas leak check again with gas leak detection device.

Apply Conversion Labels:

- Place New Inlet and Manifold Pressure Rating Sticker above rating sticker on front cover.
- Fill out information on Date, Gas Type, Kit Number, Name of Company Sticker and place on front cover.
- Include French stickers for water heaters certified for use in Canada.